

# Technical Manual **on** Utilization of Sympodial Bamboos

Fu Maoyi Yang Xiaosheng Jiang Shenxue



ITTO



CAF

China Forestry Publishing House

# Technical Manual on Utilization of Sympodial Bamboos



Fu Maoyi Yang Xiaosheng  
Jiang Shenxue

**China Forestry Publishing House**

---

**图书在版编目(CIP)数据**

丛生竹加工技术手册:英文/傅懋毅,杨校生,蒋身学著. -北京:中国林业出版社, 2007.9

ISBN 978-7-5038-4931-2

I. 丛… II. ①傅… ②杨… ③蒋… III. ①竹亚科-加工-英文 ②竹笋-蔬菜加工-英文 IV. TS65 TS255.5

中国版本图书馆CIP数据核字(2007)第146481号

© China Forestry Publishing House 2007

All rights reserved. No part of this publication may be reproduced, stored in a retrieval system, or transmitted in any form or by any means, electronic or mechanical, by photocopying, recording or otherwise without the prior permission in writing from the publisher.

Printed in the People's Republic of China

Chinese Publications Number of Archives Library: 2007-146481

ISBN 978-7-5038-4931-2

**Technical Manual on Utilization of Sympodial Bamboos: Fu Maoyi, Yang Xiaosheng, Jiang Shexue**

1. Sympodial… 2. Fu… Yang… Jiang… 3. Bambusoideae-Utilization-English Bamboo shoot-processing vegetables-English 4. TS65 TS255.5

First Published in the P. R. China in 2007 by China Forestry Publishing House

No. 7, Liuhaihutong, Xicheng District, Beijing 100009

Http: //www.cfph.com.cn

E-mail: cfphz@public.bta.net.cn

Price: RMB 45.00

# ***PREFACE***

**T**here are rich bamboo resources in the world, especially in subtropical and tropical regions in developing countries. There are 1,200 species and 70 genera of bamboo in the world, widely distributed in Asia, Africa, Australia and South and North America. The increase in the production of bamboos in many countries has often not been accompanied by better use and by appropriate modernization of the processing techniques to improve the living conditions of the rural populations.

Over the past few years, the International Tropical Timber Organization (ITTO) has concentrated its efforts on the development and transfer of technology for the processing of bamboos, for the purpose of fostering the creation of bamboo industrial enterprises.

With financial support generously provided by ITTO, RISF-CAF has embarked upon a collaborative project which focuses on management and utilization of sympodial bamboos. This Technical Manual on "Technical Manual on Utilization of Sympodial Bamboos" addresses the selected technologies of sympodial bamboos utilization in Southern China where available improved technologies can be transferred readily to other bamboo growing regions to increase bamboo production and improve incomes of the families now living in poverty through the development of bamboo utilization. It presents the direct experience acquired by the authors from RISF-CAF and Bamboo Engineering Research Centre of Nanjing Forestry University (BERC-NFU) who has implemented such activities for the purposes of training courses.

**Fu Maoyi**

Principle Scientist

The Research Institute of Subtropical

Forestry of Chinese Academy of Forestry

---

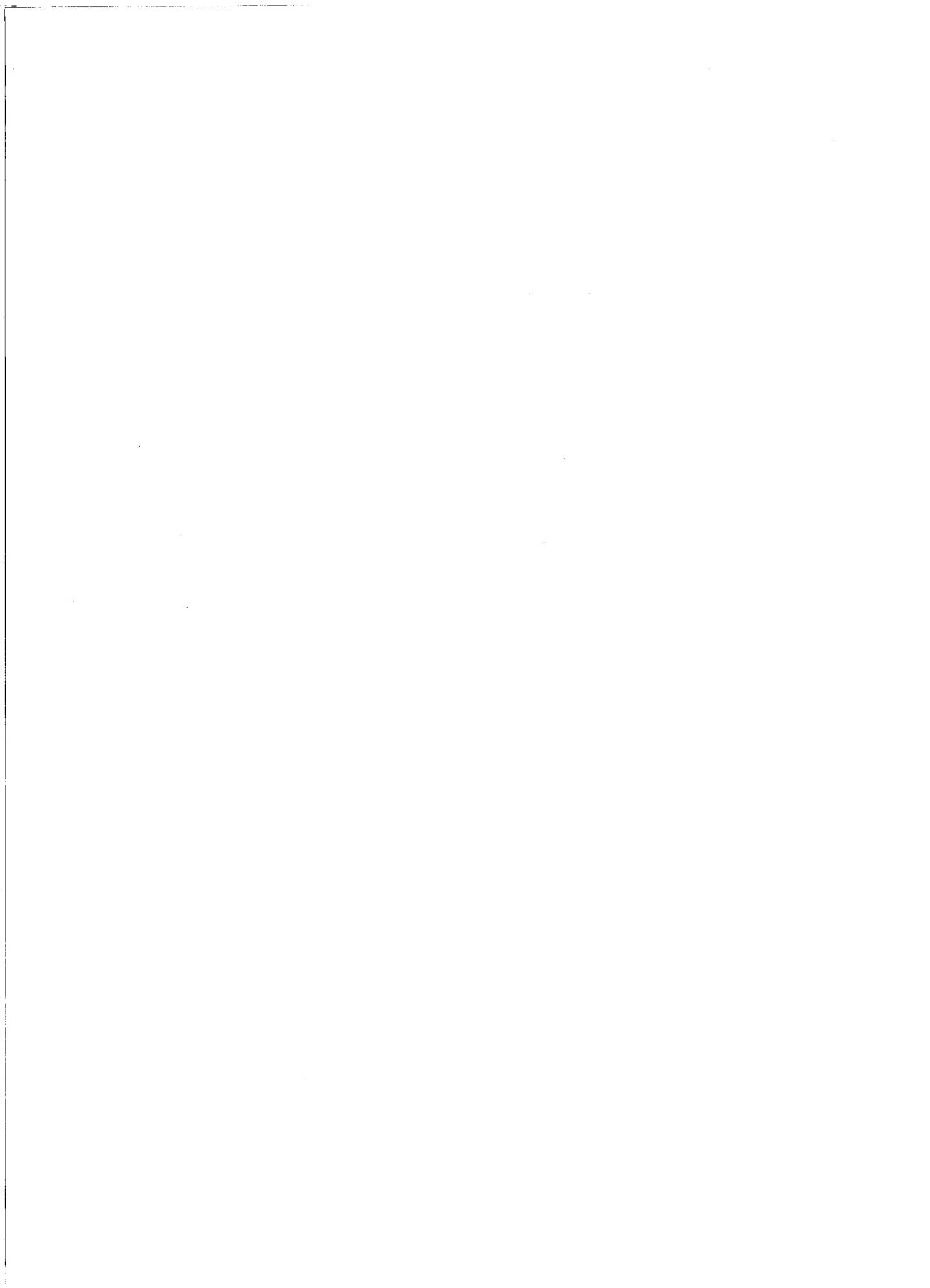

# **CONTENTS**

PREFACE

**PART I PROCESSING AND UTILIZATION OF SYMPODIAL  
BAMBOOS** ..... (1)

<b>Chapter 1</b>	<b>The Fundamental Properties of Bamboo Timber</b> .....	(3)
1.1	Distribution of Bamboo Resources .....	(3)
1.2	Macro-structure of Bamboo Timber .....	(4)
1.3	Chemical Composition of Bamboo Timber ...	(5)
1.3.1	Hemicellulose .....	(5)
1.3.2	Lignin .....	(5)
1.4	Physical Properties of Bamboo Timber .....	(6)
1.4.1	Moisture Content .....	(6)
1.4.2	Density .....	(6)
1.4.3	Dry Shrinkage .....	(6)
1.5	Mechanical Properties of Bamboo Timber ...	(7)
<b>Chapter 2</b>	<b>Processing and Utilization of Sympodial Bamboos</b> .....	(8)
2.1	Processing Features of Sympodial Bamboos ...	(8)
2.2	Categories of Bamboo Processing and Their Products .....	(8)
<b>Chapter 3</b>	<b>Traditional Processing and Its Products</b> ...	(10)
3.1	Handmade Bamboo Products for Daily Use .....	(10)
3.2	Machine-processed Bamboo Products for Daily Use .....	(11)
3.2.1	Machine-processed Bamboo Strip Mats (Thread Mats) .....	(11)
3.2.2	Domino Mats .....	(11)
3.2.3	Bamboo Weaving Crafts .....	(12)

---

## 2 *Technical Manual on Utilization of Sympodial Bamboos*

3.3	Traditional Round Bamboo Furniture .....	(16)
3.3.1	Tools for Making Traditional Round Bamboo Furniture .....	(17)
3.3.2	Parts Processing for Traditional Round Bamboo Furniture .....	(20)
3.3.3	Wrapping Tenon and Infixing Tenon .....	(25)
3.3.4	Facial Plate of Round Bamboo Furniture .....	(33)
3.3.5	Decorative Pattern on Framework of Bamboo Furniture .....	(38)
3.3.6	Making of Traditional Round Bamboo Furniture .....	(40)
3.4	Laminated Bamboo Furniture .....	(56)
3.4.1	Laminated Bamboo .....	(57)
3.4.2	Processing Features of Laminated Bamboo Furniture .....	(58)
<b>Chapter 4</b>	<b>Bamboo-based Panel .....</b>	<b>(60)</b>
4.1	Woven-mat Plybamboo .....	(60)
4.1.1	Definition and Assortment .....	(60)
4.1.2	Production Process .....	(61)
4.1.3	Preparation of Raw Materials .....	(62)
4.1.4	Making Slivers .....	(62)
4.1.5	Weaving Mat .....	(63)
4.1.6	Drying .....	(64)
4.1.7	Adhesive Coating (impregnating) .....	(64)
4.1.8	Maturing or Drying .....	(65)
4.1.9	Assembling .....	(65)
4.1.10	Hot Pressing .....	(65)
4.1.11	Edging and Checking .....	(66)
4.1.12	Physico-mechanical Property .....	(66)
4.2	Curtain Plybamboo and Mat-curtain Plybamboo .....	(66)
4.2.1	Definition, Classification and Usage .....	(66)
4.2.2	Production Process .....	(67)
4.2.3	Drying .....	(68)
4.2.4	Impregnating .....	(68)
4.2.5	Assembling .....	(68)
4.2.6	Hot Pressing .....	(69)
4.2.7	Edging and Trimming .....	(72)
4.2.8	Major Quality Standards .....	(72)
4.2.9	Brief Introduction of Mat-curtain Plybamboo with	

	Impregnated Paper .....	(73)
4.3	Glued Silver Plybamboo .....	(74)
4.3.1	Definition and Usage .....	(74)
4.3.2	Production Process .....	(74)
4.3.3	Raw Material .....	(74)
4.3.4	Drying and Impregnating .....	(75)
4.3.5	Drying after Impregnating .....	(75)
4.3.6	Assembling .....	(76)
4.3.7	Hot Pressing .....	(77)
4.3.8	Post-processing .....	(77)
4.3.9	Physico-mechanical Properties .....	(77)
4.4	Bamboo Particleboard and Bamboo Particle Composite Board .....	(77)
4.4.1	Bamboo Particleboard .....	(77)
4.4.2	Bamboo Chip Composite Board .....	(82)
4.4.3	Bamboo Particleboard Coated with Impregnated Paper .....	(85)
4.5	Bamboo-wood Sandwich Board .....	(87)
4.5.1	General Introduction .....	(87)
4.5.2	Concrete Template of Bamboo Plywood Coated with Impregnated Paper .....	(88)
4.5.3	Bamboo-wood Composite Plywood for Baseboard of Containers .....	(92)
4.5.4	Floor of Bamboo-wood Compound Assemblies .....	(97)
4.6	Production of Bamboo Floorboard and Pavement Technologies .....	(102)
4.6.1	The Structure and Classifications of Bamboo Floorboard .....	(102)
4.6.2	The Processing Technology of Bamboo Floorboard .....	(104)

<b>Chapter 5</b>	<b>Production Technologies, Properties and Utilization of Bamboo Charcoal .....</b>	<b>(114)</b>
5.1	Preface .....	(114)
5.2	Introduction of Bamboo Charcoal .....	(115)
5.3	Classifications of Bamboo Charcoal .....	(116)
5.4	Theoretical Basis of Bamboo Pyrolysis ...	(117)
5.4.1	Stages of Bamboo Pyrolysis .....	(117)
5.4.2	Products of Bamboo Parolysis .....	(118)

---



#### 4 *Technical Manual on Utilization of Sympodial Bamboos*

5.5	Production Equipment and Technology of Bamboo Charcoal .....	(119)
5.5.1	Kiln Structure .....	(120)
5.5.2	The Structure of Mechanical Furnace .....	(122)
5.5.3	Production Process .....	(123)
5.5.4	Requirement for Raw Material .....	(123)
5.5.5	The Instructions for the Main Procedures ...	(125)
5.6	The Main Quality Index and Performance of Bamboo Charcoal .....	(127)
5.6.1	The Fixed Carbon Content .....	(127)
5.6.2	The Volatile Substance Content in Bamboo Charcoal .....	(128)
5.6.3	The Ash Content of Bamboo Charcoal .....	(129)
5.6.4	The Density of the Bamboo Charcoal .....	(130)
5.6.5	The Electrical Property of Bamboo Charcoal ...	(131)
5.6.6	The Ratio Superficial Area of Bamboo Charcoal .....	(132)
5.7	Factors Affecting the Pyrolysis Process of Bamboo .....	(133)
5.7.1	The Final Temperature of the Bamboo Pyrolysis .....	(133)
5.7.2	The Speed of Carbonization .....	(133)
5.7.3	The Moisture Content of Bamboo Timber ...	(133)
5.7.4	The Size of Bamboo Timber .....	(134)
5.8	The Application of the Bamboo Charcoal...	(134)
5.8.1	The Application of the Absorbing Ability ...	(134)
5.8.2	Application of the Far Infrared Rays Ability...	(139)
5.8.3	Application in Deodorization and Keeping Fresh .....	(140)
5.8.4	Application of Other Properties .....	(140)

## **PART II BAMBOO SHOOT PROCESSING AND UTILIZATION**

..... (141)

### **Chapter 6 Utilization of Bamboo Shoots .....** (143)

6.1	Introduction .....	(143)
6.2	Nutritive Value .....	(144)
6.3	Hygienic and Pharmaceutical Value .....	(144)
6.4	Types of Bamboo Shoots .....	(145)
6.4.1	By the Growing Season and Position .....	(145)

6.4.2	By Size .....	(145)
6.4.3	By the Delicious Flavor Feature .....	(146)
6.4.4	By the Processing Type .....	(146)
6.5	The Introduction of Several Frequently Eaten Bamboo Shoots .....	(146)
6.5.1	<i>Phyllostachys heterocycla</i> var. <i>pubescens</i> (Mazel) Ohwi (Moso Bamboo) Shoot .....	(146)
6.5.2	<i>Dendrocalamopsis oldhami</i> Shoot .....	(147)
6.5.3	<i>Dedrocalamus latiflorus</i> Munro Shoot .....	(147)
6.5.4	<i>Pleiolastusamarus</i> Shoot .....	(148)
6.5.5	<i>Phyllostachys praecox</i> Chu et Chao Shoot ...	(148)
<b>Chapter 7</b>	<b>Bamboo Shoot Food .....</b>	<b>(150)</b>
7.1	Vegetables (in Need of Cooking Again) ...	(151)
7.2	Dishes (in Need of Heating with the Package or Eating Directly after Opening the Package Without Heating It) .....	(152)
7.3	Snacks (in no Need of Cooking, Having Them as Snacks Alone or Having Them When Drinking) .....	(152)
7.4	Side Dishes .....	(152)
<b>Chapter 8</b>	<b>Preserving Techniques .....</b>	<b>(153)</b>
8.1	Features Which May Influence the Preserving .....	(154)
8.1.1	Shoot-growing Quality of Bamboo .....	(154)
8.1.2	Physiological Activity .....	(154)
8.1.3	Planting and Harvesting Quality .....	(154)
8.1.4	Microorganism Invasion and Inflection .....	(154)
8.1.5	Cutting Features .....	(154)
8.2	Key Techniques in Preserving .....	(155)
8.2.1	Researches on Controllable Harvesting Techniques .....	(155)
8.2.2	Bacteriostasis and Mold-proof Techniques ...	(155)
8.2.3	Techniques of Retarding Physiological Activities .....	(157)
8.3	Bamboo Shoots Preserving Approaches ...	(159)
8.3.1	Winter Shoots Preserving .....	(159)
8.3.2	Preserving of Spring Bamboo Shoots .....	(160)

---

## **Chapter 9 Processing Technology of Bamboo Shoots**

.....	(162)
9.1 Processing Equipment .....	(162)
9.2 Methods of Processing Dried Bamboo Shoots .....	(162)
9.2.1 Water-soaked Shoot Slice .....	(164)
9.2.2 Smoking Dried Bamboo Shoot .....	(165)
9.2.3 Yellow Dried Bamboo Shoot .....	(165)
9.2.4 Dried Bamboo Shoot in Salt .....	(165)
9.2.5 Sheep-tail Bamboo Shoot .....	(165)
9.2.6 Filling Dried Bamboo Shoot .....	(166)
9.2.7 Dried Bamboo Shoot Slice .....	(166)
9.2.8 Tianmu Dried Bamboo Shoot .....	(166)
9.2.9 Ningguo Dried Bamboo Shoot .....	(166)
9.2.10 Horse-hoof Dried Bamboo Shoot .....	(167)
9.2.11 Soybean, Dried Bamboo Shoot in Brown Sugar .....	(167)
9.2.12 Sour and Spicy Dried Bamboo Shoot .....	(167)
9.2.13 Spicy Bamboo Shoot .....	(167)
9.2.14 Sweet-and-sour Dried Bamboo Shoot .....	(168)
9.2.15 Sour Dried Bamboo Shoot .....	(168)
9.2.16 Dried Vegetable Bamboo Shoot .....	(168)
9.2.17 Min Dried Shoot .....	(168)
9.2.18 Dried Bamboo Shoot in Soybean Sauce .....	(168)
9.2.19 Salty Dried Bamboo Shoot .....	(169)
9.2.20 Dried Shoot Tips .....	(170)
9.2.21 Dried Shoot Clothing .....	(170)
9.2.22 Dried Shoot Ear .....	(170)
9.2.23 Mild Dried Shoot Ear .....	(170)
9.2.24 Dried Shoot Twig .....	(170)
9.2.25 Crude Dried Shoot .....	(170)
9.2.26 Crude Sour Bamboo Shoot .....	(170)
9.2.27 Processed Sour Bamboo Shoot .....	(171)
9.3 The Salting Technique of Bamboo Shoot ...	(171)
9.3.1 Requirements for Main Raw Materials .....	(171)
9.3.2 The Technical Process .....	(171)
9.3.3 Requirements for Operation .....	(171)
9.3.4 Quality Standard .....	(173)
9.4 Water-boiled Bamboo Shoot .....	(174)
9.4.1 Technical Process .....	(174)
9.4.2 Technical Key Points .....	(174)

9.4.3	Introduction to Fresh Water Shoot .....	(176)
9.5	<b>Production Techniques of Flavoring Bamboo Shoot</b> .....	(178)
9.5.1	Soft Packed Bamboo Shoot .....	(178)
9.5.2	Oil Stewed Shoot .....	(180)
9.5.3	Sweet and Sour Bamboo Shoot .....	(180)
9.5.4	Sour and Spicy Shoot Slices .....	(180)
9.5.5	Sauce Bamboo Shoot .....	(180)
9.5.6	Bamboo Shoot and Beans .....	(181)
9.5.7	Smoke Bamboo Shoot .....	(181)
9.5.8	New Development of the Technology of Soft Package for Food .....	(181)
9.5.9	New Tendency of Soft Package for Food .....	(181)
9.5.10	New Functions of Food Package Material ...	(182)
9.5.11	New-style Transparent PET Membrane of Plastic Membrane .....	(182)
9.5.12	New-style Food Packing Paper .....	(183)
9.6	<b>GMP of Bamboo Shoot Processing</b> .....	(183)
	<b>References</b> .....	(186)



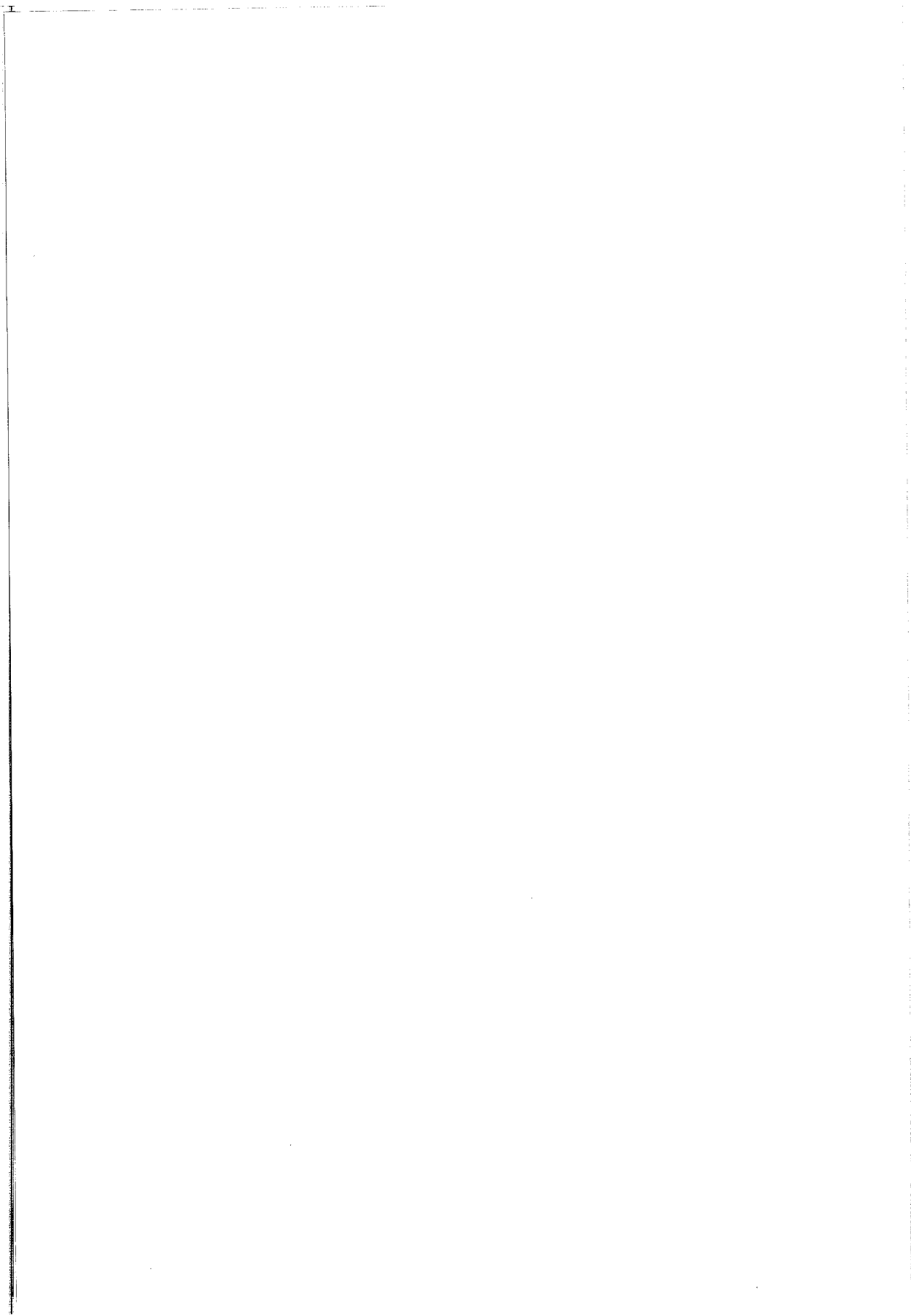

# ***PART 1***

## **PROCESSING AND UTILIZATION OF SYMPODIAL BAMBOOS**

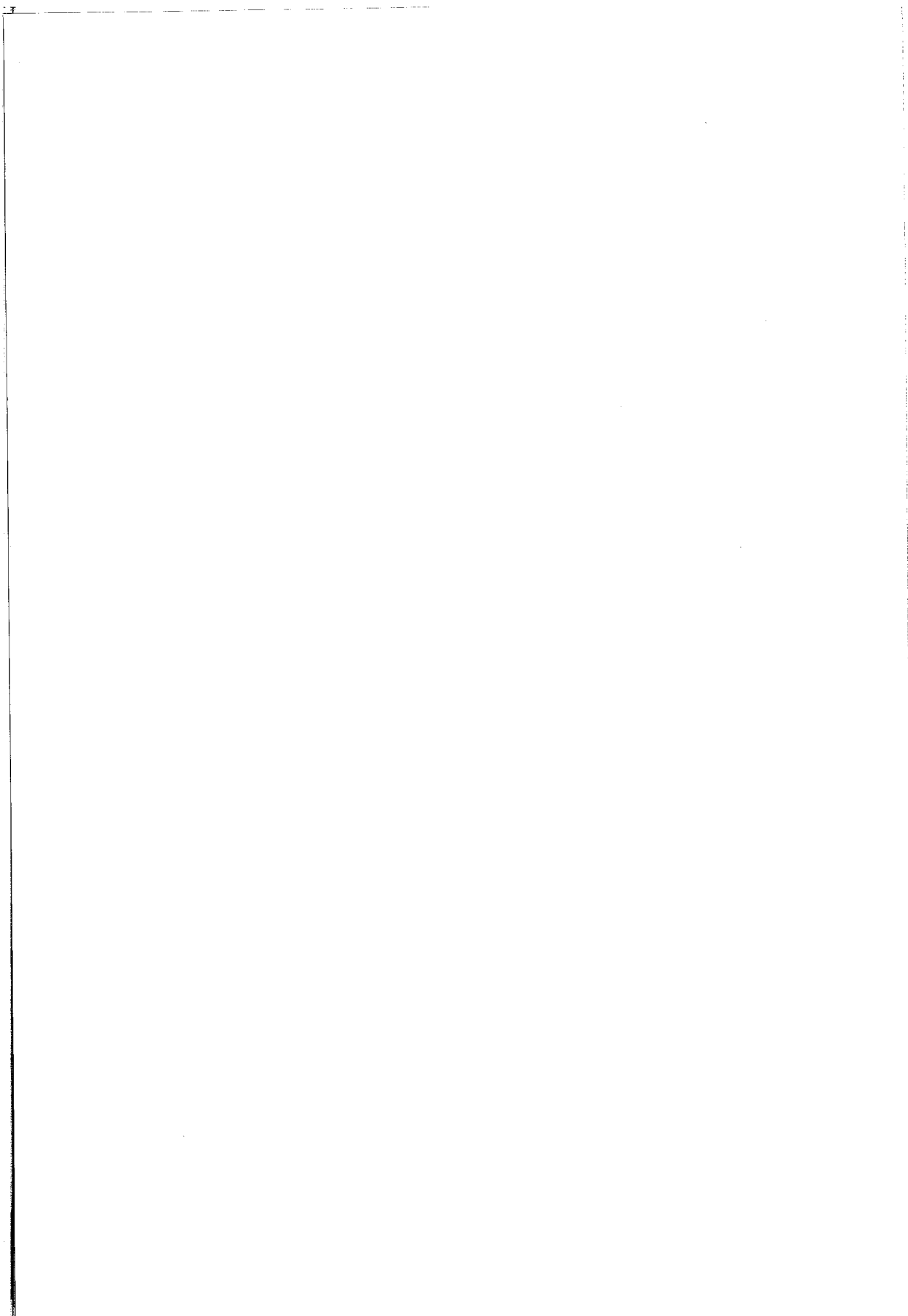

# CHAPTER 1

## The Fundamental Properties of Bamboo Timber

### 1.1 Distribution of Bamboo Resources

There are more than over 1,200 bamboo species and 70 genera in the world, which are mainly distributed in tropics and subtropics, with still a few distributed in temperate zone and frigid zone. Asia-Pacific region is the biggest bamboo-growing region in the world, extending from New Zealand of the south side ( $42^{\circ}\text{S}$ ) to the central part of Karafuto of the north side ( $51^{\circ}\text{N}$ ) in latitude, and from the southwest part of the India Ocean of the west side to the Islands in the Pacific of the east side in longitude. More than over 900 bamboo species and 50 genera are distributed in this region, among which sympodial bamboo species account for about 60%, and Monopodial bamboo species about 40% of the total. China can be taken as the bamboo distributing center in the world, having near 500 bamboo species and more than 39 genera. The total bamboo area covers more than 4.21 million ha, of which include 2.80 million ha of moso bamboo (Monopodial bamboo) which has comparatively high utility value. India is second largest bamboo distribution country in the world with 136 bamboo species and 19 genera and around 2.10 million ha of bamboo area that mainly are sympodial bamboos. Besides, there are quite rich sympodial bamboo resources distributed in Viet Nam, Burma, Bangladesh, Philippines and so on. Figure 1 shows *Dendrocalamus sinicus*, sympodial bamboos species growing in Yunnan Province, China.

There are more than 270 bamboo species and 18 genera in America, distributed from the southern part of Argentina ( $47^{\circ}\text{S}$ ) to the eastern part of the United States ( $40^{\circ}\text{N}$ ). Among all the 18 genera, 17 are sympodial bamboo species. Bamboos in this continent are mainly distributed in Latin American countries between the tropic of Cancer and the tropic of Capricorn, where there is a variety of bamboo species and some of these have comparatively high utility value, such as *Bambusa*

---



*Guadus* which are originally distributed in Costa Rica and Columbia has high utility value because of characteristic of tall and straight culms, and has extended to all countries of Latin American.

African has a relative smaller distribution area with several native bamboo species. There are only more than 10 species that include the introduced bamboo species. There are no naturally distributed bamboo species in Europe, but it has begun introducing bamboo species in recent years. See Figure 1.1.

## 1.2 Macro-structure of Bamboo Timber



**Figure 1.1** Biggest Sympodial Bamboos in the World; *Dendrocalamus sinicus*

The structure of bamboo material is observed under microscopes of different magnifying power, which is based on the view of physics.

The macrostructure of bamboo timber refers to the composition of bamboo culms with people's naked eyes and under amplifiers. On a bamboo culm's transverse section, there are many dark diamond-shaped spots; while on its longitudinal section, they are strand-looking tissues. They are vascular bundles, which can be picked out with a knife.

Bamboo stem wall is composed of three parts: bamboo skin, bamboo timber and pith. Bamboo skin is the outermost part of cross section of stem wall, where no vascular bundles are seen. Pith is the part of stem wall next to bamboo cavity, it does not contain vascular bundles too. Bamboo timber is the part between skin and pith. Vascular bundles are observed on its cross section, among vascular bundles are fundamental tissues. The density of vascular bundles decreases from outer side of stem wall to inner side. The outer part where vascular bundles are dense is called bamboo skin, while the inner part where vascular bundles are rare is called bamboo yellow.

The distribution of vascular bundles of cross section of stem wall is showed in Figure 1.2.

### 1.3 Chemical Composition of Bamboo Timber

The organic composition of bamboo timber is quite similar to that of wood. It consists of cellulose (about 55%), lignin (about 25%) and hemicellulose (pentosan, about 20%).

#### 1.3.1 Hemicellulose

It is mostly composed of pentosan, with little hexosan. 90% of hemicellulose in bamboo timber is made up of xylan. Experiments have shown that bamboo xylan is D-glucuronate arabinoxylan, which comprises 4-oxygen-methyl-D-glucuronate, L-arabinose and D-xylose. Their molecule ratio is 1.0:1.0-1.3:24-25, as follows:

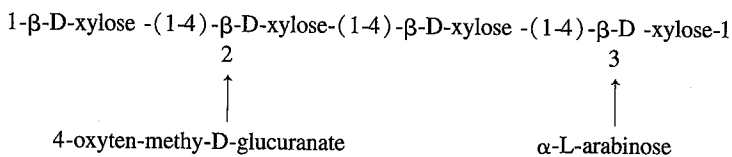

The composition of arabinoxylan of bamboo is different from that of conifers and broad-leaved trees. The polymerized molecules of bamboo xylan are more than that of tree. The content of pentose in bamboo timber is between 19% and 23%, which is close to that of broadleaves and much higher than that of conifers (10% - 15%). This indicates that bamboo timber can not only be used to make pulp or hydrolyze, but also be synthetically used as uronic acid.

#### 1.3.2 Lignin

bamboo timber lignin is a typical herbaceous lignin, which is composed of three phenyl propane units, i. e. paradinum, guaiacyl and mauve in the ratio of 10:68:22. This means the bamboo lignin is similar to broad-leaved lignin qualitatively, not quantitatively.

The specific features of bamboo lignin lie in the existence of dehydrogenated polymerides and 5% - 10% of acrylic ester. The lignin content of one-year old bamboo is in the range of 20% - 25%, approaching to broad-leaved wood and some grass (such as straw of wheat 22%) and is a little lower than that of conifers. Less lignin content means less consumption of chemicals in pulping process and easier

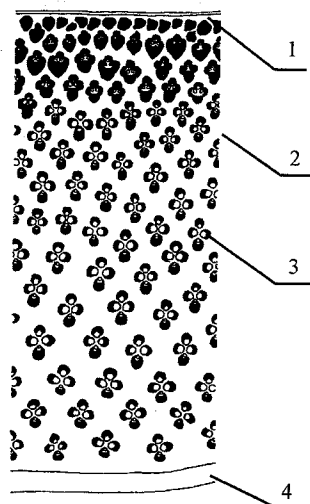

**Figure 1.2** Macrostructure of Cross Section of Stem Wall  
 1. Bamboo skin 2. Fundamental tissue  
 3. Vascular bundle 4. Pitch

pulping process.

## 1.4 Physical Properties of Bamboo Timber

### 1.4.1 Moisture Content

As the rule, the moisture content of growing bamboo is rather high, but it varies as seasons change. It also varies among different bamboo species and different bamboo culms. The moisture content of moso bamboos at cutting age is approximately 80%.

The equilibrium moisture content after air-drying varies as air temperatures and humidity change. According to the statistics, the equilibrium moisture content of moso bamboo in Beijing area is 15.7%.

### 1.4.2 Density

The basic density of bamboo timber (the mass of the whole culm/ the volume of the raw bamboo timber) is between 0.40 and 0.8 (0.9) g/cm<sup>3</sup>. This is mainly depends on the density and the composition of vascular bundles. As a rule, the density of a culm grows gradually from inner to outer part, and from lower to upper part. The thickness of the culm reduces as it grows taller and the density of the culm's inner part increases while its exterior part has little change. The density of bamboo timber node is a little bigger than that of the internode.

### 1.4.3 Dry Shrinkage

After it is cut, during the process of its drying, the bamboo timber is shrunk because of water evaporation. The shrinkage of the bamboo timber has obvious differences in different directions. From its air-drying to full drying, when its moisture content is reduced by 1%, the average shrinkage of moso bamboo is measured and the results are: longitudinal direction 0.024%, tangential direction 0.1822%, radial direction 0.1890% (on node parts 0.2726%, on inter node parts 0.1521%). Obviously, the shrinkage in longitudinal direction is much less than that in radial direction, while there is not much difference between the shrinkage in tangential direction and that in radial direction.

The shrinkages of the inner part and the exterior part are also different even at the same horizontal height of a bamboo culm. The shrinkage of "bamboo green" part in longitudinal direction is so small that it can be purely ignored while its shrinkage in radial direction is the biggest; the absolute value of the shrinkage of "bamboo yellow" part in longitudinal direction is still small even though it is bigger than that of "bamboo green" while its shrinkage in radial direction is much smaller

than that of “bamboo green”.

Bamboo begins to shrink as soon as it gets dried, which is different from how wood does. When water loss arrives at certain level, the shrinkage of bamboo timber almost stops, but if it is further dried, shrinkage process resumes. Such a phenomenon should be researched further.

## 1.5 Mechanical Properties of Bamboo Timber

Bamboo timber is similar to wood timber in that both are heterogeneous and anisotropic materials. Therefore, both the physical and mechanical properties of bamboo timber are very unstable, with some of them even more unstable than those of wood timber. Its complexity is reflected in the following aspects:

Due to the uneven distribution of vascular bundles, bamboo timber's densities, shrinkages and intensities vary as the heights of bamboo culms and the positions (inner part, exterior part) change. Generally speaking, the vascular bundles in the exterior part of a bamboo timber culm are distributed more densely than those in the interior part, so all kinds of its intensities are comparatively higher. And the density of a bamboo timber culm gradually grows from the bottom to the top, so all kinds of its intensities also grow higher.

The increase or the reduction of moisture content also leads to the changes of density, shrinkage and strength. According to the measurements, when its moisture content is 30%, the compression strength of moso bamboo is only equal to 90% of that when its moisture content is 15%; while some others report the difference was twice more.

The node parts and inter-node parts have different physical and mechanical properties. For instance, the intensity of tension of node parts is weaker than that of non-node parts.

Bamboo timbers with different bamboo ages also have different physico-mechanical properties. Bamboo timbers of below 2-year old are usually tender, lacking a proper strength; those of between 4-year and 6-year old are tough, with high mechanical strength; while those of above 7-year old become brittle with decreased strength.

Bamboo timber's physico-mechanical properties are also different in three directions. For example, the cleavage strength parallel to grain of bamboo timber is quite small.

To sum up, the physico-mechanical properties of bamboo timber are very different with complex affecting factors. Therefore, all the complex features should be taken into full consideration for the utilization of bamboo material.

---

# CHAPTER 2

## Processing and Utilization of Sympodial Bamboos

### 2.1 Processing Features of Sympodial Bamboos

In bamboo plants, sympodial bamboos show us various morphologies. Some of them are tall, big diameter, thick stem wall such as *Dendrocalamus sinicus*, *Dendrocalamus giganteus*, *Bambusa guadua*, and some of are small in diameter, short in length with different thickness in stem wall such as *Sinacalamus affinis*, *Bambusa textiles*, *Lingnania chungii* ect. Therefore, different processing measures are needed to take to deal with the different sympodial bamboos species. By making use of *Phyllostachys pubescens* bamboo processing equipment, for instance, larger diameter sympodial bamboos can be cut into bamboo strips with the settled width and thickness as the basic processing components, which are then processed for such products as flooring and laminated furniture. And for those bamboo culms with thinner stem wall, it is better first to process them into fine slivers, which can be used to weave handicrafts, or coarse bamboo slivers that will be weaved into mats or curtains as the fundamental components of bamboo based panels. As for the small diameter culms with thicker stem, it fits to be made into bamboo charcoal. The sympodial bamboos with bad configuration should be used as the raw material of pulp and paper.

### 2.2 Categories of Bamboo Processing and Their Products

Though the research and processing of sympodial bamboos lag behind those of *Phyllostachys pubescens*, almost all bamboo-growing nations, including China, are interested in the utilization of sympodial bamboos. Moreover, most existing moso bamboo processing equipment can be used for processing sympodial bamboos. With

the technical improvement, most current bamboo products can be made from sympodial bamboos.

According to their degrees of industrialization, bamboo timber processing can be classified into traditional processing and modern industrialized processing. According to their use, they can be classified into bamboo articles for daily use and industrial bamboo products. In accordance with the processing measures and fundamental components, bamboo processing can be classified into the following methods: bamboo stem, slivers, strips, particle, bamboo and wood composite. They are showed in Figure 2. 1.

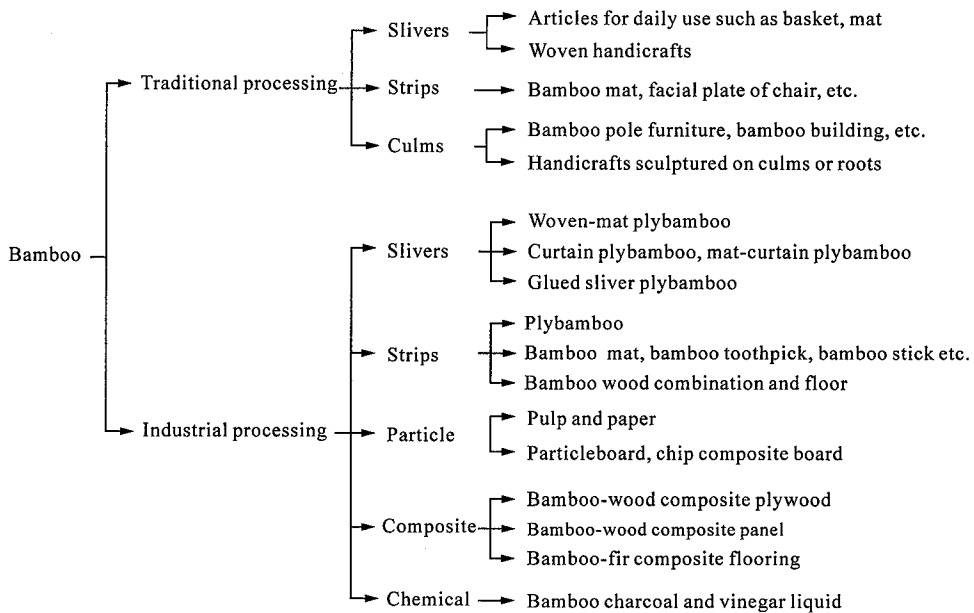

Figure 2.1 Classification of Bamboo Processing Measures and Products

# CHAPTER 3

## Traditional Processing and Its Products

### 3.1 Handmade Bamboo Products for Daily Use

Bamboo products for daily use refer to the products such as mats, baskets, plates, trays, jars, boxes, shoulder pole, fish pole. Usually bamboos are split and cut into thin strips to weave all kinds of farm implements and articles of daily use. Bamboo poles can also be directly used after being straightened. Farmers in the bamboo-growing regions usually make them by hand as handmade family sideline production during slack farming seasons and sell them at local markets. Both the production and sales of these products are dispersed and a large quantity of them are demanded. However their values are not high because making them needs simple tools such as knife for cutting and making slivers, scraper, etc. and little making skill. Handmade bamboo products for daily use are widely used in towns and villages of all bamboo producing countries and are particularly welcomed in rural areas due to the advantages they hold such as handy use, fine goods with cheap prices and so on. Sympodial bamboos are mostly raw materials for these products since they are very easy to be cut into thin strips. Figure 3.1 shows the bamboo articles for daily uses made with sliver or strips in widely using in southern China.

Bamboo mats woven by hand usually take monopodial bamboos such as *phyllostachys pubescens*, sympodial bamboos such as *Sinacalamus affinis*, *Bambusa textilis*, and *Bambusa eutililoides* as raw materials. To make exquisite bamboo mats, however, *Bambusa*

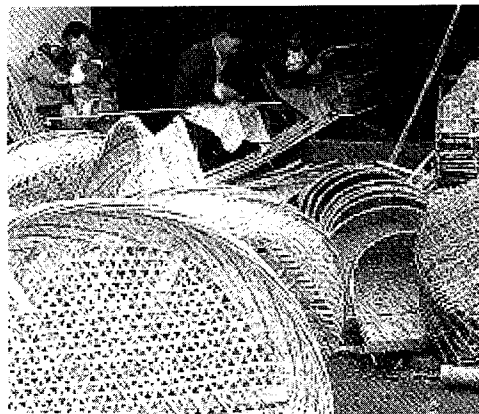

Figure 3.1 Various Bamboo Products Widely Used in Southern China

*eutuliloides* is needed due to its cool, smooth, soft with glittering and translucent color, fine grain and superb heat dissipation.

## 3.2 Machine-processed Bamboo Products for Daily Use

Machine-processed bamboo products for daily use mainly include mats, chopsticks, toothpicks etc. As a result of the development of bamboo processing sector, the mechanization production of these products has replaced handwork.

Bamboo mats, one of the main bamboo products in China, are manufactured in all the provinces of southern China. According to their components, machine-processed bamboo mats can be classified into two sorts: machine-processed bamboo strip mats and bamboo domino mats.

### 3.2.1 Machine-processed Bamboo Strip Mats (Thread Mats)

There are many steps in the process of producing bamboo strip mats. Raw bamboos are first cut into bamboo strips. They are then polished, steamed and cooked with high temperature, sterilized and bleached, woven by machine, glued, heated and pressed, and finally stitched and edged. According to the quality of different parts of bamboo culms, the mats can be divided into categories of Raw Green, First layer green, Second layer green, Colored strip, Lacquering strip and Spun threads. They can be used for beds, cover pillows, chair cushions, sofa cushions, car seat cushions and so on. They have advantages such as original design, fine work, being cool and comfortable, being durable in use, mothproofing, anti-fungus and so on, so that they are very popular among customers. Moso bamboo and appropriate sympodial bamboos can be used for machine-processed bamboo strip mats.

The technological flow of making bamboo strip mats goes as follows:

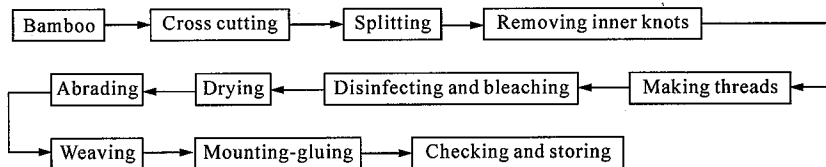

### 3.2.2 Domino Mats

Bamboo domino mats are newly developed in the recent years. Raw bamboo culms are first cut into standard small hollow lumps. After mothproofing, anti-fungus, bleaching and polishing, they are woven into shape by tough nylon yarn. This treated domino mats has good ventilation, cool, comfortable and durable. To meet customers' demand, they can also be woven into pillow mats, sofa cushions,



chair cushions, car seat cushions, etc. which hold different uses, different sizes, different colors and patterns. The manufacturing process of domino mats is as follows:

### 3.2.3 Bamboo Weaving Crafts

With different processing methods, bamboo crafts can be classified as woven, carved and bamboo engraved crafts. Up to now, the latter two kinds of crafts have been mainly made from moso bamboo and will not be explained in detail here.

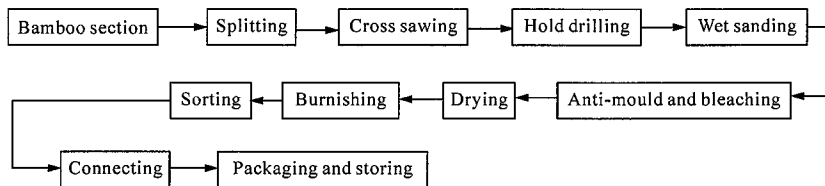

Both monopodial bamboos and sympodial bamboos can be used for making woven handcrafts. The best raw materials for bamboo weaving crafts are those sympodial bamboos with good bamboo splitting feature such as *Neosinocalamus affinit* Keng f. , *Bambusa textilis* McClure, *Phyllostachys heteroclada* Oliver, *Bambusa cerosissima* McClure, etc. All of them have long internodes and tough fiber.

With the steps of cutting, node removing, cross-cutting, splitting, stripping, drawing, threading and smoothing, bamboo can be processed to make all kinds of bamboo threads and strips. Figure 3.2, 3.3, 3.4, 3.5, 3.6, and 3.7 illustrate the main procedures of making bamboo threads and strips.



Figure 3.2 Splitting

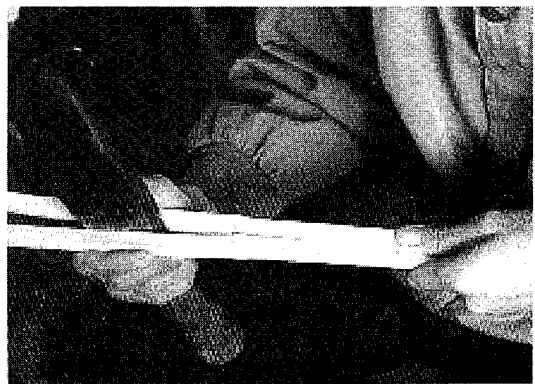
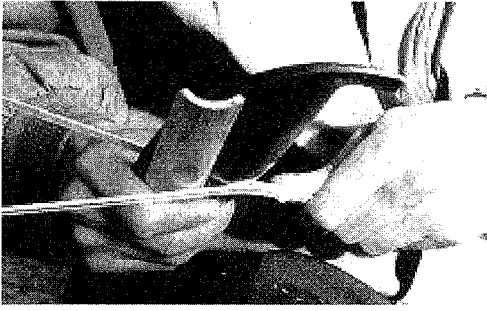
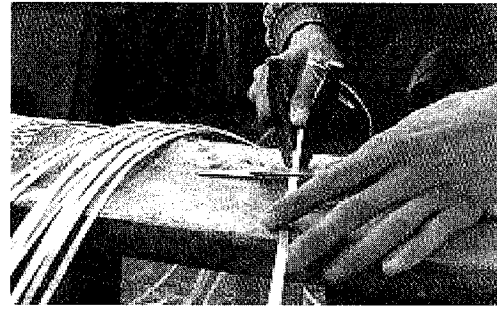

Figure 3.3 Cleaning Node



**Figure 3.4** Stripping



**Figure 3.5** Drawing

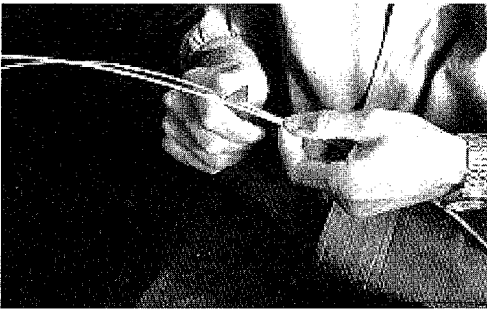

**Figure 3.6** Threading

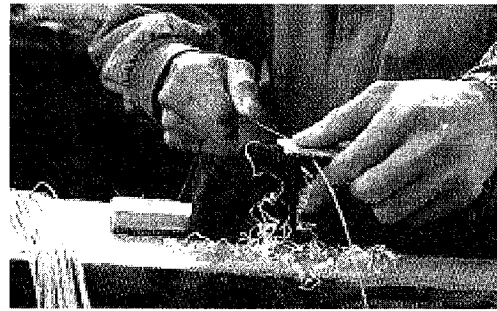

**Figure 3.7** Smoothing

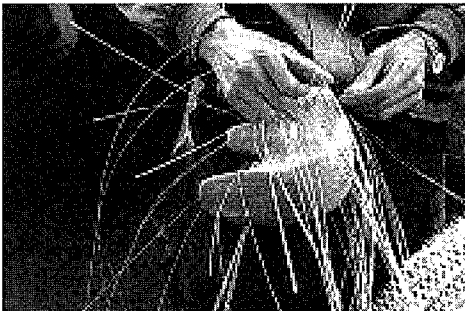

**Figure 3.8** Weaving

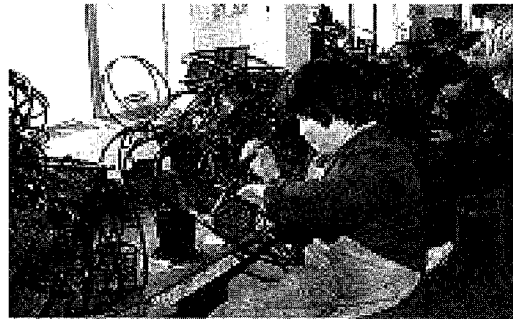

**Figure 3.9** Lacquering

Weaving articles are finished through passing strips or threads crosswise over and under lengthwise ones. Lengthwise strips are called warps and crosswise ones are called wefts. In order to further beautify them and guard against moth-eating and mildew, most bamboo woven articles need lacquering. Figure 3.8 and Figure 3.9 respectively illustrate weaving and lacquering.

Bamboo woven articles are composed of two categories: utensils and decoration.

Utensils include baskets, plates, trays, vases, pots, boxes, cases, curtains,

fans and so on with different patterns. Figure 3.10 is a kind of bamboo weaving baskets. Figure 3.11 is a kind of bamboo thread trays and cases, and Figure 3.12 shows a variety of bamboo weaving vases with porcelain kernel.

Bamboo weaving articles for decoration includes animals, portraits, archaized buildings etc. Taking bamboo weaving animals as an example, Shape design is the first step for weaving animals, and then they are woven into shape based on the models of animals which either are made of wood or gauze. The skins of animal are woven concavely or convexly by means of increasing or decreasing the bamboo strips. In order to enrich animals' colors, craftsmen have applied different techniques such as bleaching and strip coloring (Figure 3.13 and Figure 3.14).



Figure 3.10 Bamboo Weaving Baskets

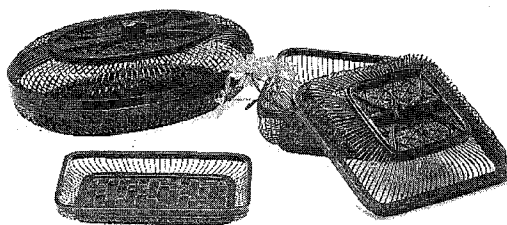
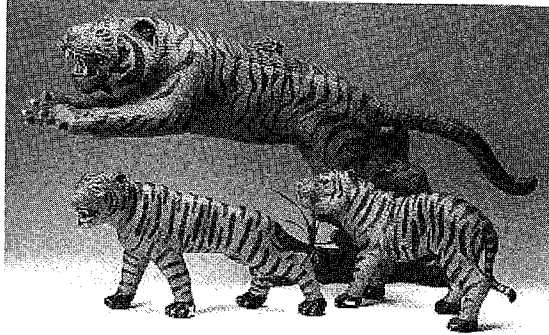

Figure 3.11 Bamboo Thread Trays and Cases



Figure 3.12 A Variety of Bamboo Weaving Vases with Porcelain Kernel



**Figure 3.13** Bamboo Weaving Tigers

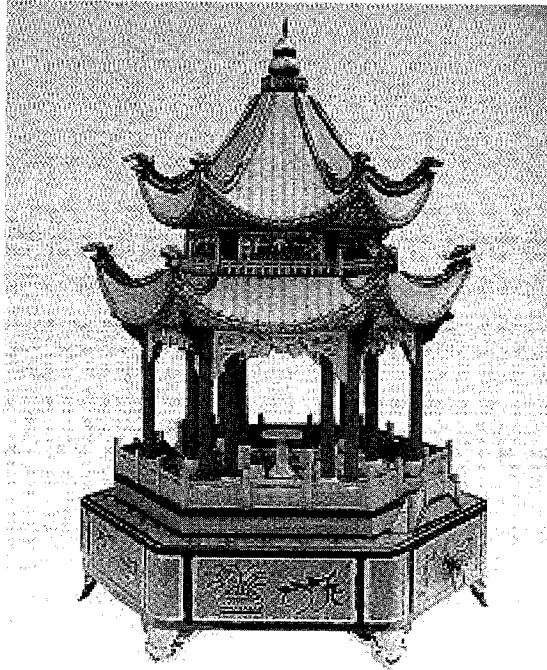

**Figure 3.14** Bamboo Weaving Peony Pavilion

Bamboo weaving screens include 1 entrance screens, hanging screens and folding screens. Figure 3.15 illustrates a bamboo weaving folding screen named as “Bo Gu Folding Screen”. The Chinese characters “Bo Gu” means being conversant with the things past.

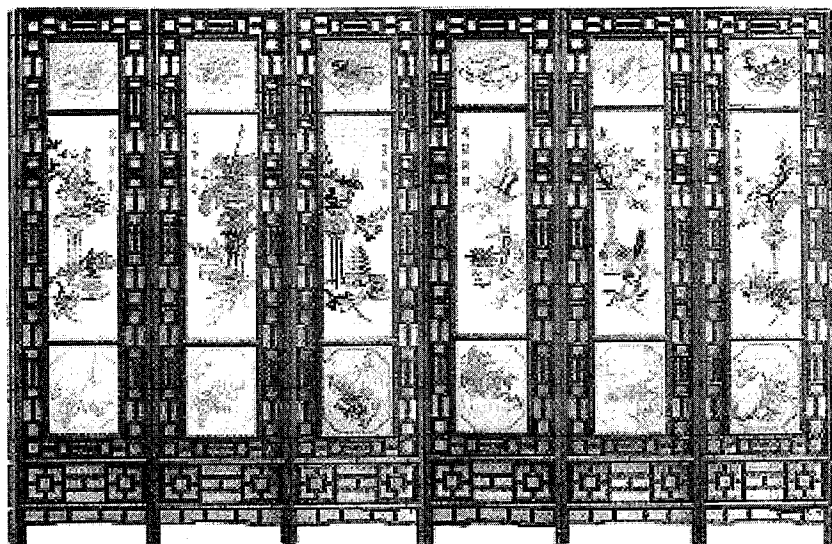

Figure 3.15 Bamboo Weaving Article "Bo Gu Folding Screen"

### 3.3 Traditional Round Bamboo Furniture

The production and utilization of round bamboo furniture has long history in China. Bamboo furniture is permeated with a strong local flavor, in simplified and elegant style, pleasantly cool and comfortable, and light and handy. They have been long favored by customers, domestic or abroad. They have been widely used particularly in southern China.

Bamboo species such as *Phyllostachys pubescens* Mazel ex H. de Lehaie, *Pseudosasa amabilis* (McClure) Keng f., *Phyllostachys heteroclada* Oliver, *Bambusa textilis* McClure, *Neosinocalamus affinis* (Rendle) Keng f. or *Phyllostachys sulphurea* cv. *Viridis* are normally chosen as raw materials in making traditional round bamboo furniture according to their specific features. Various traditional skills are taken, such as bending, reinforcing, connecting, drilling, chiseling, notching, rabbeting, surfacing, laying out a board, lining up a board, and board covering, possibly further enlaced with rattan or plastic strips. Round bamboo furniture includes stools, chairs, tables, cabinets, beds, tea table, bookshelves and so on. Traditional round bamboo furniture are unadorned and distinctive flavor, which coincides with nowadays people's vogue of returning to sense of reality and approaching nature. Hence, it has been developed quickly in recent years.

The processing of traditional bamboo furniture goes through three stages: bending framework into shape, reinforcing and decorating framework and arranging

bamboo strip on surface. Light and beautiful round bamboo culms are bent into appropriate curvatures by means of broiling or notching, then tenon wrapping or tenon infixing, and further reinforced by combining bamboo culms side by side or by connecting ends of bamboo culms. The surface of furniture is made from bamboo strips arranged side by side and finally decorated and beautified with grillwork. All of these are the basic workmanship of processing traditional round bamboo furniture.

### 3.3.1 Tools for Making Traditional Round Bamboo Furniture

Manufacturing traditional bamboo furniture is a traditional craftwork. Recently, although some special mechanical equipments are widely used, the operation by hand is still playing a dominant role. The introduction of Chinese usual tools is as follows:

#### 3.3.1.1 Bamboo strip knife

Bamboo strip knife is a basic tool for making bamboo furniture. It is used in cutting, cleaving and scraping of the bamboo node and bamboo strips. The bamboo strip knife is about 38cm in length, with 26cm of the knife-blade and 12cm of the hilt. The hook at the point of the knife can scrape the bamboo knot. The back of the knife blade is relatively thick (with about 1.5cm in thickness), which will augment a certain amount of strength while using (Figure 3.16).

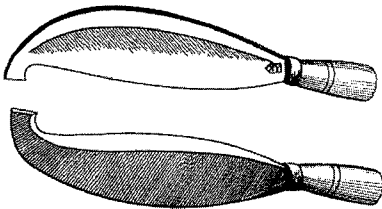

Figure 3.16 Bamboo Strip Knife

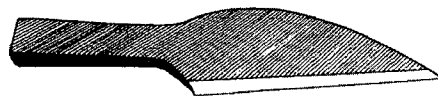

Figure 3.17 Sharp Knife

#### 3.3.1.2 Sharp knife

Sharp knife is a usual tool for making bamboo furniture. It is used in dibbling, trimming, framing, assembling and cleaning. It is usually small and handy with sharp knifepoint and edge (Figure 3.17).

#### 3.3.1.3 Scraping knife

Scraping knife is a special tool for scraping off the waxen layer on the surface of bamboo node. The knife is cambered, with arched edge and back and wooden hilt at both ends for operators to hold (Figure 3.18).

#### 3.3.1.4 Gouge

Gouge is a special tool for making tenon of bamboo furniture. It is used to gouge out the fiber of yellow skin layer and inter-layer of bamboo culm. The gouge is columnar, with edges at both ends. While using, pinch the hilt with five fingers, with the palm tightly resisting against the knife bow. As the gouge is under the wrist, both the front and the back sharp edge can cut into the bamboo culm and gouge off the bamboo fiber by pushing forward or pulling backward (Figure 3.19).



Figure 3.18 Scraping Knife

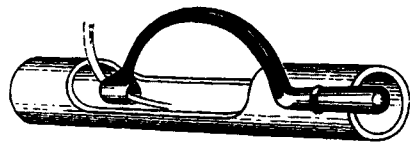

Figure 3.19 Gouge

#### 3.3.1.5 Planer of bamboo knot

Planer of bamboo knot is a special tool for planing off the tubers and knots of the bamboo. Its shape is similar to woodworker's planer but much smaller and lighter. With a concave at the underside of the wooden block, it can easily plane off the knots by cycling around the columnar bamboo culm. While operating, press the planer tightly against the knot surface of the bamboo node, making it rotate in the direction of the knot circle (Figure 3.20).

#### 3.3.1.6 Rolling planer

It is used to plane the bamboo surface or bamboo strip and make it flat or straight. The function of the rolling planer is similar to the woodworker's planer but seems light and handy and more suitable for making bamboo products (Figure 3.21).

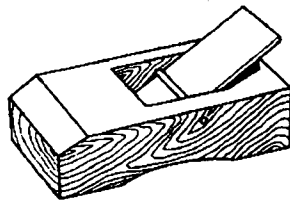

Figure 3.20 Planer of Bamboo Knot

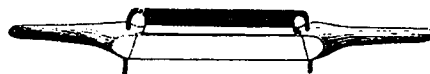

Figure 3.21 Rolling Planer

#### 3.3.1.7 Cleaving knife and chisel

Cleaving knife and chisel are mainly used for "opening" bamboo culms so that the bamboo culms are split equally and shapely to meet the requirement for the designed

furniture. The cleaving knife is usually 12cm long, 3cm wide, with the back of the blade about 0.5cm in thickness. The outside of the knife is the edge, which is not necessarily sharp, with an iron hilt at the end. The shape of bamboo chisel is similar to woodworker's chisel but seems light and handy (Figure 3.22).

### 3.3.1.8 Round gouge and square gouge

Round gouge and square gouge are tools for cutting holes. The round gouge is responsible for cutting round holes, which are used for assembling bamboo board. While square gouge is for cutting square holes, with different size of 3mm, 6mm, 10mm, etc. (Figure 3.23).

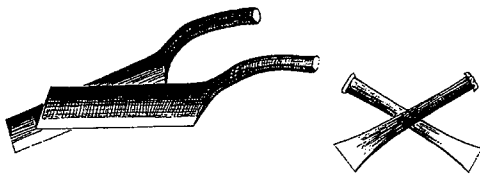

Figure 3.22 Cleaving Knife and Chisel

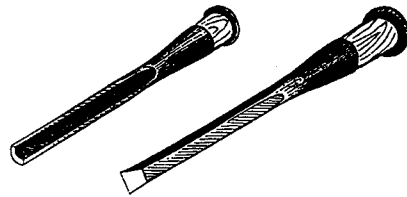

Figure 3.23 Round Gouge and Square Gouge

### 3.3.1.9 Handsaw

Handsaw is specially designed for sawing off bamboo node or strips and sawing out kerfs of different depths on the bamboo node. It is a usual tool in the process of making bamboo furniture. According to the requirement of the bamboo furniture, the most frequently used types of saw are frame saw and steel saw. With thinner saw blade, smaller and denser saw tooth, the steel saw seems more refined and handy than the frame saw (Figure 3.24).

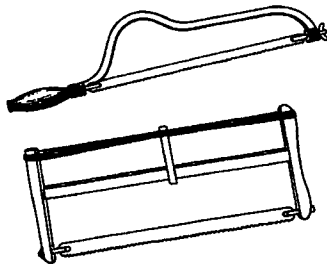

Figure 3.24 Handsaw



Figure 3.25 Saw Blade

### 3.3.1.10 Saw blade

Saw blade is a special tool for pinning the bamboo board. Saw blade is short, inserting tightly into an iron clip, with wooden hilt attached to it. While using, hold the



hilt and trim the bamboo surface with saw teeth (Figure 3.25).

### 3.3.1.11 Hand drill

Hand drill is the tool for boring when making bamboo furniture. Before wedging bamboo nail into bamboo node or bamboo strip, we must make holes, so drill is an indispensable tool. Since the bamboo culm is relatively thin and easy to split, the drill should be sharper, with appropriate weight. We should prepare different models of drills for various uses and needs (Figure 3.26).

### 3.3.1.12 Hammer

Hammer is mainly used for striking bamboo nails or round nails when assembling bamboo furniture, so it is more light and handy than woodworker's hammer.

### 3.3.1.13 Bending column

Bending column is an assistant tool to bend bamboo rods by firing. Make a wooden "T" frame, with the upright pole about 13cm in width and 250cm in height. Bore several round holes with 3-5cm in diameter through the pole at the place of 120 – 140cm to the bottom. While operating, incline the fire pole against the wall, insert the bamboo rod into the hole, and soften the part which needs bending with fire (Figure 3.27).

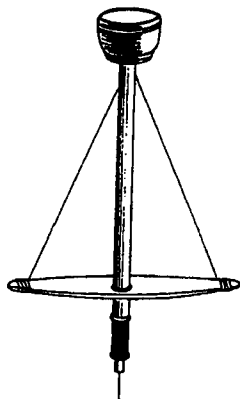

Figure 3.26 Hand Drill

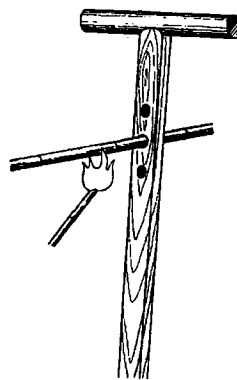

Figure 3.27 Bending Column

## 3.3.2 Parts Processing for Traditional Round Bamboo Furniture

### 3.3.2.1 To bend bamboo culm

Bamboo culms can be bent by means of heating or fluting.

### a. Heating

Bamboo culms are thermoplastic. Thermoplastic performance can be improved by raising the temperature on the condition that bamboo is highly hydrated. Heating, especially for small diameter bamboo culms, can maintain the original appearance and keep the rigidity.

The fire is often used in heating to bend the bamboo culms. They will keep bent when cooled. Bamboo is generally planed and shaved after bending. To keep the bamboo skin away from being burnt, smokeless firing material is generally welcomed. Roast the part-need-to-bend, slowly intensify to bend the bamboo to the correct angle when oil drops show on the inner wall. Then keep the bamboo in cold water for 1-3 minutes to recover the rigidity and maintain the form by decreasing sharply the temperature of the part-need-to-bend (Figure 3.28).

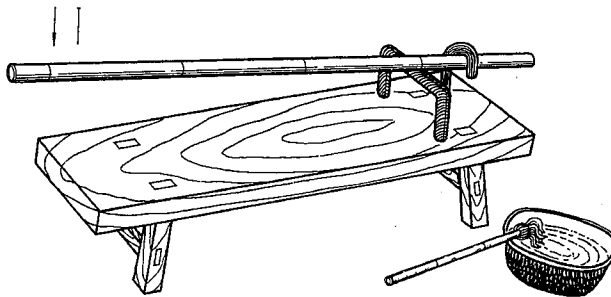

**Figure 3.28** Corrective Table for Straightening Bamboo Culms by Means of Roasting

In large-scale production, bamboo can be put into shaping mould after being roasted flexible. In addition, bamboo can also be heated by vapor: Put bamboo into the mechanic mould placed in the thermo-container, then steam it, bamboo will be gradually shaped to the planned angle in high temperature after being cooled. To diminish the breaking and pressing parts because of stress while being heated, we can break the bamboo partitions inside the bamboo culms and insert the hot sand into the bamboo culms. Sand will be cleared after the slow shaping.

### b. Fluting

Fluting is often adopted to bend the larger diameter bamboo culms and to bend the legs of round-bamboo furniture and horizontal frame. Fluting requires more complicated process and somehow affects intensity. The dimension and lineate position in a selected culm should be identified for fluting according to different requests, and then smooth the flute and remove the inner bamboo yellow, roast and bend the fluted part, insert the pre-made culm or round wooden stick into the flute, tightly clip,

and refrigerate it into right form. Be aware that all flutes should be at the position of internodes and preserve within a vertical line when bending horizontal components. If crossed or skewed, they cannot complete the assembly and may cause distortions or cracks. Fluting to bend varies with different bending angles as followings:

**Paratactic bending.** As shown in Figure 3. 29, bending part is Hoop and bounded part is Head. When paratactically bent,  $D$  (Hoop's diameter)  $\geq 4/3$  semi-diameter of  $h$ . Paratactic bending includes single, double and multiple head. Their sizes are respectively (supposing there are  $n$  hoops):

$$\text{flute depth: } D/2 \leq h \leq 3D/4$$

$$\text{flute arc semi-diameter: } R = r = h$$

$$\text{flute length: } L = 2\pi r + 2(n-1)r - 2R$$

**Regular bending.** Regular bending has many types but only single head is used. Final products can be Three-folding Bending (regular triangle) and Six-folding Bending (regular hexagon) (see Figure 3. 30). If there is an angle  $\alpha$  in the final product, it is called  $\alpha$ -Folding Bending (Figure 3. 30), displayed by the following equations:

$$\text{flute depth: } L = 2\pi r - \alpha\pi r/180^\circ$$

$$\text{flute arc semi-diameter: } R = r$$

$$\text{flute length: } h \leq r + r \sin(\alpha/2)$$

$$\text{folding angle: } \beta = 90^\circ + \alpha/2$$

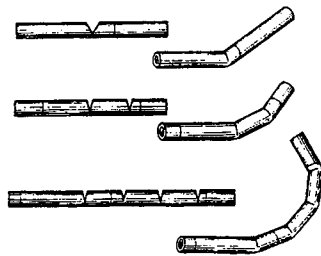

Figure 3. 29 Paratactic Fluting

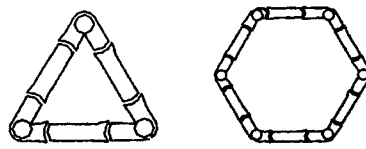

Figure 3. 30 Regular Bending

Three, four, five, six, eight, twelve and eighteen-folding are most used bending. The Table 3. 1 is for reference of making them:

**Table 3.1 Data for Regular Bending with Different Folding**

Title	Angle $\alpha(^{\circ})$	Length $L$	Angle $\beta(^{\circ})$	Height $h$
3 angle	60	5.23 $r$	120	1.50 $r$
4 angle	90	4.71 $r$	135	1.71 $r$
5 angle	108	4.39 $r$	144	1.81 $r$
6 angle	120	4.17 $r$	150	1.87 $r$
8 angle	135	3.92 $r$	157.5	1.92 $r$
12 angle	150	3.66 $r$	165	1.97 $r$
18 angle	160	3.49 $r$	170	1.98 $r$

*c. Triangle bending*

A triangle flute, dog-teeth-like, is sawed in the inner side of bending part. After roasting, culm should be intro-bended and refrigerated. This method is used for large-diameter culms. Its disadvantages are the intensity of bamboo internodes might be weakened and much sophisticated technique is required. Triangle bending includes regular-round bending and angle-round bending.

**Regular-round bending.** Make the bent culm regular round (Figure 3.31) such as in round table surface. Generally, regular-round components have enclosed border. The equations of making it are as follows ( $n = \text{flutes}$ ):

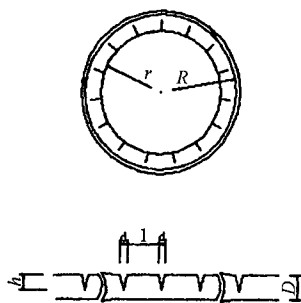

**Figure 3.31** Regular-round

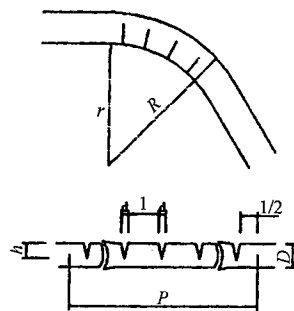

**Figure 3.32** Angel-round

wrapped border length:  $L = 2\pi R + \text{adapter length}$

wrapped border net length:  $L_{net} = 2\pi R$

peristome depth:  $D/2 \leq h \leq 3D/4$

peristome width:  $d = 2\pi h/n$

peristome intervals:  $l = 2\pi r/n$

**Angle-round bending.** Culms should be bent to certain angles (Figure 3.32). Generally it is made for sofa armrest and round angle tea table surface. The equations of making it are as follows ( $n = \text{flutes}$ ):

bent part length:  $P = \alpha\pi R/180^\circ$

peristome depth:  $D/2 \leq h \leq 3D/4$

peristome width:  $d = \alpha Jh/180^\circ n$

peristome intervals:  $l = \alpha Jh/180^\circ n$

When processing with triangle bending, ensure by orderly lining off length, number of burls and peristome width. Bamboo nodes should not be planed too smoothly. Repetitious linings are needed. Peristome must be smooth and be without agnail. Slices and glues are required if peristome is too wide.

### 3.3.2.2 Reinforcement of bamboo framework

Single-culm skeleton is not enough for bamboo furniture to load much. Reinforcement is integrant to strengthen framework. Multiple paratactic culms are needed to intensify framework.

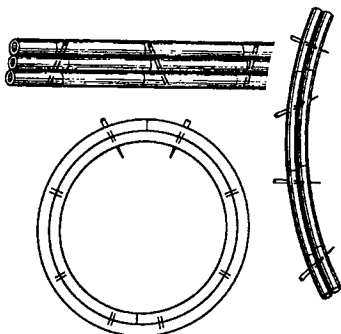

Figure 3.33 Bamboo Culm's Paratactic Reinforcement

Reinforced paratactic culms improve the loading performance and make furniture capacious, neat and easy to handle. It has to smoothen and insert tightly the interfaces between paratactic culms by using a strip knife, and then to penetrate the culm walls by using a hand drill and insert bamboo nails to complete the reinforcement (see Figure 3.33). Different drilling angles are required to inter-strengthen. The interface should be smoothed when processing more than two paratactic culms, and then smoothen the culm heads by using a handsaw after nails are stuck in, and cut and smoothen the

nail heads and tails by using a strip knife. Finally they have to be polished. Bending angles of paratactic culms should be identical, or distortions may happen in them.

### 3.3.2.3 Joints between bamboo culms

Not until joined with other round bamboo culms or slices can culms be made furniture framework after their being bent. Generally, joining methods include head joint, T-like joint, paratactic joint, embedded joint, cross-like joint and L-like joint, etc.

Head joint is applicable to lengthening iso-diameter culm or joining close frameworks. The heads of culms to be joined must be cut evenly, then select a small culm, of similar or same diameter with heads' hollow part, to be the joining component. Insert small culm into the hollow parts of heads after gluing. Penetrate and join if knars remain. Keep the heads tightly connected. Insert bamboo nails to two different directions into heads of both culms by using a hand drill. Cut and

smoothen the nail heads and tails to complete the joining (Figure 3.34).

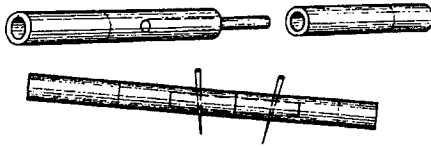

Figure 3.34 Straight Joining

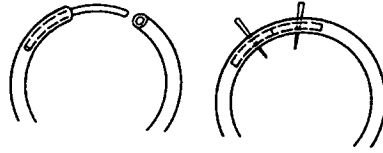

Figure 3.35 Bent Joining

Use the same way to join the bent culm. The only difference is to bend the distal culm accordingly (Figure 3.35). If two heads are not similar in diameter, the larger diameter culm should be considered first. Cut and smooth the other half of distal culm in order to be tightly stuck in smaller-diameter culm after the first half has been tightly stuck. After tightly combining both interfaces, cut and mend larger diameter culm to make both culms in similar diameter. Polish to complete the joining.

When big differences in size happen between joined head and tail, means of “enclosure joints” which will be introduced in the next section can be applied.

Bamboo nails are widely used to intensify in producing paratactic culms and joints. Dry bamboo culms with thick walls are popular in making bamboo nails. Dry bamboo has less shrinking performance, and even performs better after the culm is out of water. It is convenient to make bamboo nails. Nails are about 10cm long and their width is about to be the same as their corresponding culm walls'. The bottom part of nails should be pared into a cone. Different parts of bamboo furniture require different types of nails. The larger diameter nails are needed in the parts where loading capacity is required and smaller-diameter nails are for decorative parts.

### 3.3.3 Wrapping Tenon and Infixing Tenon

Bamboo furniture mainly consists of “skeleton bamboo culms” and “bamboo liners”. Skeleton culms, generally long, function in making the whole framework. Bamboo liners, generally short and slender, function in supporting and strengthening skeleton culms and bamboo strip boards.

The assembling of bamboo furniture lies on “tenons”. Tenon for skeleton culms are “wrapping tenon”. Tenon for liners are “infixing tenon”.

#### 3.3.3.1 Wrapping tenon

Tenons for wrapping and fixing skeleton culms are wrapping tenons, which are extremely important to the furniture structure. “Tenoning at the peristome”, “enclosure bamboo culm” and “enclosure joints” are often seen.

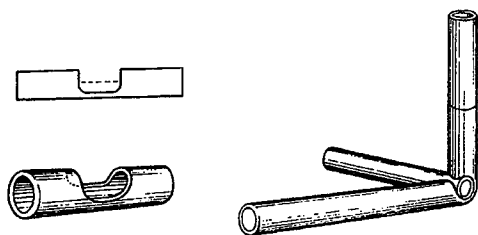

Figure 3.36 Tenoning at the Peristome

*a. Tenoning at the peristome*

The making contains three steps. First, make the peristome for wrapping tenon. Cut two vertical peristomes on one side of a culm by using a handsaw. The distance between two peristomes should be determined by culms' perimeters and the total number of them. The depth of a

peristome can be slightly longer than the semi-diameter of culms but must be within  $3/5$  of diameter. Cut the wall between two peristomes by using a strip knife. Second, cut an arched peristome. Cut the two right angles from square into arc by using a sharp knife and smoothen the interface. Third, in order to make the tenon tightly wrap and stick to skeleton culms, pare the yellow facet of the peristomes' bottom thin and remain the green facet. The remaining facet should be proper in thickness. Compactness can be affected if too thick while fastness can be reduced if too slender. Thickness is proper within 0.2-0.5cm. Peristomes must be smooth and even in thickness and width. Wrapping can be unstable if too wide while fastness will be reduced if too narrow. Generally their width is identical to the diameter of the peristome culms (Figure 3.36). To avoid the facet's breaking when bending cut-out peristome, the inner part of the facet must be heated. Two approaches are available. One is to put the green facet and the yellow facet of the peristome on fire in turn and move back and forth, bend it when intenerated. Be aware not to over-heat, or the fastness may be affected. The other is to heat the facet with boiling water and then to bend.

Two more points must be noticed when making peristomes:

(1) Peristomes can only be made on internodes, but never on nodes. The fastness of peristomes is easily affected since the arrangement of nodes' fibers is in disorder.

(2) One culm should control at least two cut-out peristomes which can only be one the same side of the culm.

*b. Enclosure bamboo culm*

"Enclosure bamboo culm" is a culm with set length that is enclosed with at least three skeleton bamboo culms by means of cut-out peristome tenoning and then reinforced together.

Enclosure bamboo culm, by which each main skeleton culm is tightly tenoned and most bamboo strip boards are fastened, plays a very important role in structuring bamboo furniture. Even the liners supporting boards are assembled on enclosure bamboo culms. Therefore, the making and processing of enclosure bamboo culms is

definitely critical in producing bamboo furniture.

Enclosure bamboo culm is skeleton culm as well. Its making and processing consists of cut-out peristome tenon and its head-tail joint.

Its perimeter should be the same or similar to that of the skeleton culm which is tenoned with, which can make each peristome's length equal and make the final wrapping tenon fast.

"3- side enclosure", "4-side enclosure", "5-side enclosure", "6-side enclosure" and enclosures with even more sides are often seen.

**Regular 3-side enclosure.** Its length is the sum of three sides' length and three peristome wrapping tenons' length. Its length does not need to be increased if the thickness of its head and tail are similar or the same, and "bolt joint" can be applied. If the thickness of head and tail are very different, then "enclosure joint" should be applied and the joint length must be added to the whole enclosure bamboo culm's length. Enclosure joint is popular in ends' joining, which will be introduced in the following sections.

The length of peristome wrapping tenons of regular 3-side enclosure must be calculated accurately. Generally, the length should be  $\frac{5}{8}$  of the perimeter of the part of the skeleton bamboo culm wrapped by this peristome. The length can be reduced by 1-3mm to make wrapping tenons fastened in real operation (Figure 3.37).

Each angle of regular 3-side enclosure is  $60^\circ$ . The length of peristome wrapping tenon should be properly shortened or lengthened if irregular 3-side enclosures are in demand. The shorter the peristome, the bigger the angles of the bamboo culm, and the longer the two corresponding sides of the enclosure. Nevertheless, regular 3-side enclosures are mostly used in making bamboo furniture, with few irregular ones.

**Regular 4-side enclosure.** The calculation of its length is the same as that of regular 3-side enclosure. However, the length of its peristome wrapping tenon is different from that of regular 3-side enclosure. It is  $\frac{9}{16}$  of the perimeter of the part of the skeleton bamboo culm wrapped by this peristome and each angle should be  $90^\circ$ . Four sides should be equal in length and the interval between peristomes should be equal as well (Figure 3.38).

**Rectangle 4-side enclosure.** It is a rectangle enclosure. The calculation of the lengths of its enclosure culm and peristome wrapping tenons is the same as those of regular 4-side enclosure.

**Regular 5-side enclosure and regular 6-side enclosure.** The calculation of enclosure culms is the same as the above mentioned while peristome wrapping tenons' calculations are different. The length of peristomes of regular 5-side enclosure is  $\frac{1}{2}$  of the perimeter of the enclosed culms. Each angle should be  $108^\circ$ . The

---



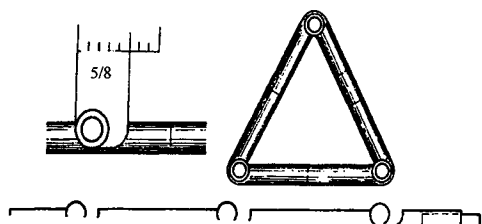

Figure 3.37 Regular 3-side Enclosure

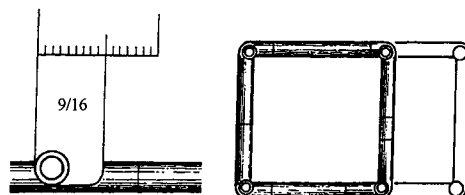

Figure 3.38 Regular 4-side Enclosure

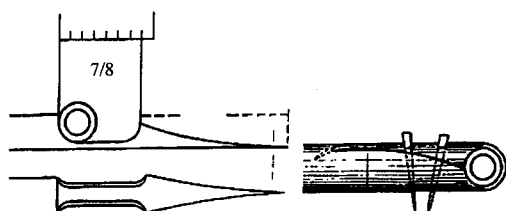

Figure 3.39 Fully-wrapping Tenon

length of peristomes of regular 6-side enclosure is  $15/32$  of the perimeter of the enclosed culms. Each angle is  $120^\circ$ .

*c. Fully wrapping tenon*

Fully-wrapping tenon is to wrap the whole circumference of the skeleton

culm based on peristome tenoning. Its making is to firstly leave a sawed peristome 30cm to the head, the depth of which is half of the culm's diameter. Then remove the half of the culm that has been sawed, plane the rest half of the culm inclined and make the yellow facet thinner by using a gouge. The bottom part should be flexible with 1cm long acumination. Then make a peristome wrapping tenon at the starting point of the inclined plane. The length of the peristome should be  $7/8$  of the perimeter of the enclosed culm (Figure 3.39).

Next, wrap the skeleton culm by means of peristome wrapping tenon. Fold, wrap and stick tightly together the half of intenerated inclined plane of the enclosure bamboo culm. Drill on the relevant position of the enclosure bamboo culm, insert and wedge the bottom acumination (Figure 3.39), and sidelong insert two dry bamboo nails to reinforce. It can be further fastened if being wrapped with rattan around the thin wall and the outside part of the enclosure bamboo culm. It is a way worth popularizing.

*d. Enclosure joint*

Enclosure bamboo culms are generally long and thus the thickness of their head and tail are usually not in unanimity. Bolt joints cannot be applied here. They need a special joining method that is called enclosure joining.

Enclosure joint is made at the culm head. Make the joint while handling peristomes. Not until the tenoning between peristomes and the skeleton culm is made can the joining of head and tail of the enclosure culm be operational.

Enclosure joint consists of single joint (Figure 3.40) and double joints (Figure

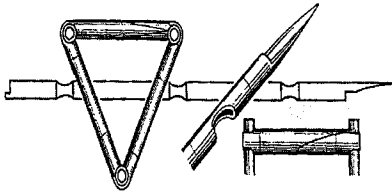

Figure 3.40 Single Joint

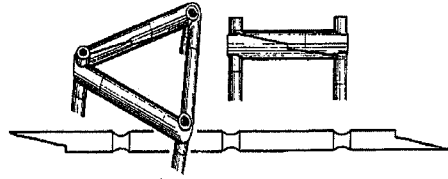

Figure 3.41 Double Joints

3.41). Its making is the same as that of the culm ends with fully wrapping tenon. One can learn how to make it by studying the illustrations. Extras should be noticed:

(1) The half sharp inclined plane of the enclosure joint is vertical to the peristome, while the joints of the bamboo culm with fully wrapping tenon are on the same one side as where the peristome is.

The half inclined planes of the double joints' ends should face oppositely. The two half inclined planes should adhibit tightly together after the ends are joined (Figure 3.41).

(2) The length of each half inclined plane should be 1/2 one side length of enclosure. Both the cut culm will become one side of enclosure after joining.

(3) Enclosure joints must be wedged sidelong by bamboo nails.

### 3.3.3.2 Infixing tenon

Infixing tenon is the tenon head, protruding from the bamboo liner. The according tenon hole on the framework can make the tenon head tightly inserted in. Bamboo nails are needed to fasten after the insertion. It is essential to dry the bamboo timber which are to be infixed with tenons or they may be loose and fall off.

Infixing tenon can make the bamboo furniture good in appearance and easy to handle but not as intensified as wrapping tenon is. Various types of infixing tenons can be found, such as mid-wall, level, bevel and dovetail infixing tenon, and fish mouth etc. Different types can be applied under different demands.

#### a. Mid-wall infixing tenon

Make tenons in the middle of heads of bamboo liners. Make a slightly out-inclined saw-mouth in the middle of two heads of the liner. The saw depth should be 3/8 diameter. Leave a base for tenon between two mouths, carefully use bamboo strip knife to remove the walls on both sides of tenon heads. Then pare and cut the interfaces arc and the tenon teeth in the middle can be used as tenon heads of mid-wall infixing tenons (Figure 3.42).

Bore two round holes on the bamboo timber where a tenon needs to be infixed. Process them into tenon holes where tenon heads can be infixed tightly. And make

the heads penetrate one layer of culm wall and stick the opposite wall through the inner diameter. Therefore, the length of tenon heads should be the result of diameter of inserting culm minus the thickness of wall (Figure 3.43).



Figure 3.42 Mid-wall Infixing Tenon Head

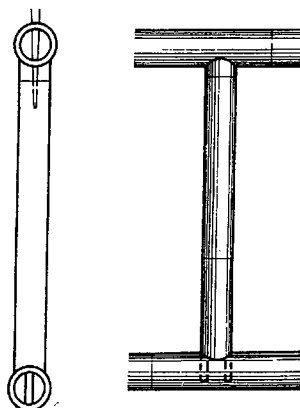

Figure 3.43 Mid-wall Infixing Tenon

There is another special form which is called “cross mid-wall infixing tenon”, which means making the head’s length slightly longer than the width and pass through the whole culm. It has the same making method as the one mentioned above. The only difference is to cut the tenon hole into rectangle where the length is equal to the width between the two heads, and coming-in length is slightly longer than the coming-out length. Cut the dry wood stick into wedge-like and insert it into the vacant space between two heads. Remove exposed parts and fix them with bamboo nails (Figure 3.43).

Mid-wall infixing tenon, neat and clean, is often used for vertical assembling.

*b. Half-wall infixing tenon*

Make Half-wall infixing tenon at the head of a liner (Figure 3.44). Make a saw-mouth about 2cm to the head interface. The depth of mouth is equal to the semi-diameter. Remove the half bamboo wall on the mouth side to complete the making. The length of half-wall infixing tenon is appropriate only if it can lean tightly against the inner wall.

The half-wall infixing tenon, correspondingly on the framework culm, is a semicircular hole whose diameter equals the diameter of the liner. Be aware that the making of semicircular hole should be parallel to the culm veins. Joining cannot be completed if sidelong crossed. Intensity will be reduced if constrainedly tenoned.

Half-wall liner can be assembled horizontally or vertically. See Figure 3.45.



Figure 3.44 Half-wall Infixing Tenon

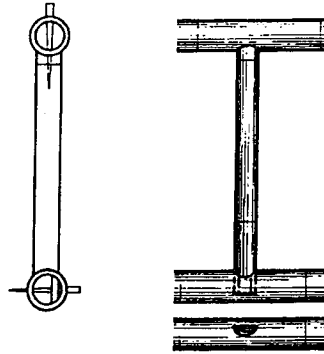

Figure 3.45 Sketch Map of Half-wall Infixing Tenon

*c. Fish mouth*

Fish mouths, set up between two horizontal framework culms to support the whole, are often seen in tenoning.

Liner heads, functioning as fish mouth, must save the nodes and partitions. Make the head V-form by using the handsaw without damaging the partitions. Cut and pare into an arc concave, like a mouth fish, and make the head stick tightly to the arc of framework culm (Figure 3.46). Generally, the fish mouth upwardly holds the framework culm.

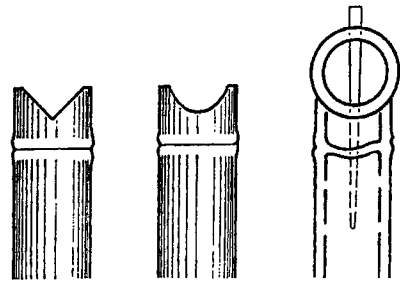

Figure 3.46 Fish Mouth

*d. Level infixing tenon*

Level infixing tenon needs no processing of liner heads. Liner heads can be level on one end or two. If only on one end, the other end is fish mouth. Make two holes on the infixing position on the framework culm by using a hand drill, then cut and pare them to the holes whose diameter equals the liner head's diameter.

The assembling of level infixing tenon heads: to infix one end and then pull the other culm away to make the other level head infixed into the tenon mouth. If it is a single level, insert one end and pull the other end to the proper position along the last culm's direction. Make the upward fish mouth lean tightly against the culm wall and the bottom into the tenon, tightly against the inner wall as well. Fasten the drilling holes by using bamboo nails to complete the

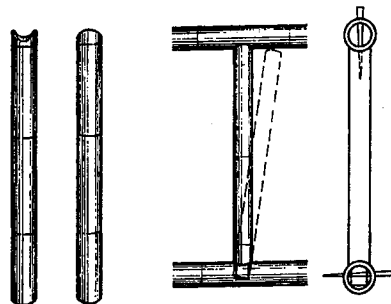

Figure 3.47 Level Infixing Tenon

assembling. Be aware that nails must penetrate the wall and partitions on mouth level end, and nails on level head must penetrate the culm and wall of liner head as well to make them intensified (Figure 3.47).

Level liner, widely used in producing bamboo furniture, is installed between framework culms, horizontally or vertically. Be aware that the level liner cannot be over-thick or the mechanic functions may be affected.

*e. Bevel infixing tenon*

Bevel infixing tenon has bevel tenon at the liner head (Figure 3.48). The liner also is called as bevel liner.

Bevel infixing tenon cannot be wholly infixed into the hole. It is not suitable for first-class furniture due to its less tight combination. Generally, bent liner cannot be directly tenoned vertically with culms and bevel infixing tenon is thus applied.

Bevel infixing tenon can be single or double headed. Be aware that the inclined interface must face the same direction as the fish mouth on the other end does if it is a single bevel tenon (Figure 3.49). Intensity will be affected otherwise.



Figure 3.48 Bevel Infixing Tenon

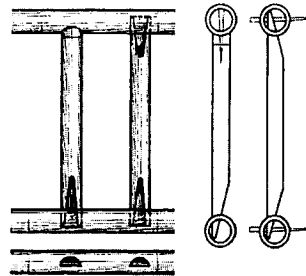

Figure 3.49 Sketch Map of Bevel Infixing Tenon

*f. Dovetail infixing tenon*

Tenon heads at the liner end face the inclined interface, which look like a dovetail. This liner is also called as a dovetail liner.

Dovetail infixing tenons (Figure 3.50) have two drilling holes as tenon holes. The space between the two holes must be equal to the space between the dovetails. Dovetail tenon is always single headed and the other end is generally fish mouth. Bamboo nails are fastened at the fish mouth (Figure 3.51).

Dovetail infixing tenon is seldom applied in first-class furniture for its less intensity and integrity. It can be horizontally or vertically assembled between culms, among which more vertical assembling can be found. The relationship between dovetail infixing tenon and fish mouth is the same as that between bevel infixing ten-

on and fish mouth.

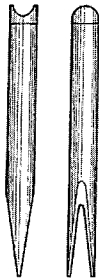

Figure 3.50 Dovetail Infixing Tenon

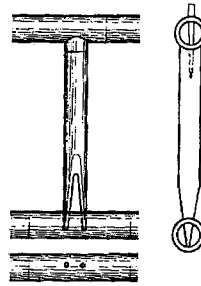

Figure 3.51 Sketch Map of Dovetail Infixing Tenon

### 3.3.4 Facial Plate of Round Bamboo Furniture

The “faceplate” of the bamboo furniture is an indispensable major part, such as seat and back of a chair, top of a table, base of a bed, sideboards and shelves. All these plates are made of bamboo strips.

Before making all kinds of facial plate, it firstly needs to fix a bamboo frame, which is called “bamboo frame for fixing plate”. It is mostly quadrate, sometimes it is round, elliptic or even with irregular shape. Correspondingly, the shapes of the facial plates should also adapt to it. To fix the facial plate, we need install a “bamboo liner” (also called as supporting scaleboard) to support the plate. And the bamboo scaleboard is vertical to the bamboo strips of the plate. The most common plates can be made of bamboo fragments or of bamboo strips.

#### 3.3.4.1 Facial plate of bamboo fragment

Facial plate of bamboo fragment refers to a plate making method by conducting the following procedures such as fragment cracking, spreading out, assembling, sewing up and planing. With its low cost, it is widely accepted, especially for common products of small and medium size. As a traditional way of making bamboo furniture plate, it can be divided into four steps.

##### *a. Fragment cracking*

After the bamboo culm is cracked into fragments, they are spread out to form a plane. Such plates can be made in the form of knot plate or non-knot plate.

Non-knot plates are made of the bamboo material between one internode, which is used for the production of small-sized furniture. First of all they are split a bamboo culm into two half fragments, orderly make slits on the green surface of fragment from the left to right, with the space between of 0.3 – 0.4cm and the length of the slits  $\frac{3}{5}$  of the full-length bamboo culm, making sure the bamboo



Figure 3.52 Cracking Bamboo Fragments

culm is cleaved squarely and the knife is pointing at the center of the bamboo culm, and then make slits on the surface of the other end, making sure the cleaving slot is between the two slots of opposite end, so the bamboo strips will connect to one another without falling off when the bamboo culm is spread out (Figure 3.52).

Knot plates are made of raw materials with knots, which are used for the production of larger furniture. The process of cracking is similar to that of non-knot plate, but the space between slit should be 0.4 – 0.5 cm.

#### b. Assembling fragments

The slit fragments are assembled into a plate upon requirements for the design if furniture. While assembling, the same size fragments should be arranged together and they are of appropriate thickness so the plates can be flat and square. They have to be trimmed with knife if connecting areas are not tight and seamless.

#### c. Sewing up

The slit fragments have to be sewed up together with bamboo thin strips. The production procedure is as follows: install a tool to fix the slit fragments on a working stool, laying the slit fragments with the yellow skin upwardly. Below the fragments, there are two pieces of parallel crossties, and the space between the crossties should be adjusted to the length of the fragments. Above the fragments, a pressing stick is set in the middle of it, with one end hitched to the ringer fixed to one side of the working stool. Slowly put the other end down and beat out the two ends and two sides of the fragments with the back of a bamboo strip knife. When the fragments are pressed flat and orderly, the other end of the pressing stick is hitched to the other side of the working stool with rope. Then prepare a thin bamboo strip which is about 0.5 cm wide and 0.2 cm thick, and it is a little longer than the width of the fragments. Hold the slit saw with right hand, in the vertical direction of the fragments, saw a straight line with  $\frac{2}{3}$  depth of the thickness of fragments. Then move

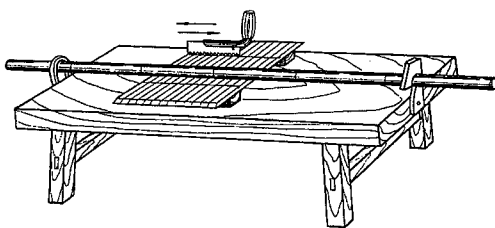

Figure 3.53 Sewing Fragments

the fragments slightly outward, slowly exert your strength at one end, create sewing crevice along the sawing line, insert the thin bamboo strip along the crevice (Figure 3.53). There should be usually two sewing crevices for small-size furniture and four sewing crevices for large-scale one.

#### d. *Planing plate*

After sewing fragments, plane the bamboo's inner yellow parts at the two ends, shaping the plate a cuniform of a flat bottom and slanting slopes. The width of the inclined plane of the cuniform is about 4 – 5cm, with its edge thickness 0.02cm. While operating, lay the plate on the slab of the working stool, making bamboo's inner yellow parts upwardly and the outer bamboo green parts flatly lie on the slab, with the above pressing stick tightly press against the plate. Then plane the plate in the vertical direction of fragments with short planer (hand planer) to make the inclined slope flat and smooth, without wailness and curves (Figure 3.54).



Figure 3.54 The Plate after Being Planed

#### 3.3.4.2 Facial plate of bamboo strips

Facial plates of bamboo strips are made of parallel bamboo strips. The strips should be of the same width, thickness and similar color, even of the same space between every two strips if arranged loosely. The width of the strips is usually 0.7 – 2 cm, in accordance with the size of the plate and the style of the furniture. The strips can be relatively wider for bulky furniture and a little narrower for small-size exquisite furniture. To avoid the curves raised on the surface and ensure a flat and smooth plate, strips made of large-caliber bamboo can be wider and those made of small-caliber bamboo narrower.

There are three kinds of such plates based on the strip-arranged procedures, i. e. holes-fixed plate, slit-fixed plate and pressing-fixed plate.

##### a. *Holes-fixed plate*

The holes-fixed plate is formed by inserting one end of bamboo strip into the hole-mortise at the inside of the bamboo culm that is used to fix a plate. Before insert tenon, both the ends of strips must be cut into dowels. The production method of dowels is as follows: make a vertical kerf of 2cm to join or fasten securely at both ends of the strip with hand saw, cleave off two sides of the end with bamboo strip knife, leaving a tenon in the middle, scraping it into a pinhead. The size of the tenon should accord with that of the mortise, so that the tenon can closely match with the mortise. The strips can either be densely or loosely arranged by adjusting the space between mortises (Figure 3.55 and Figure 3.56).



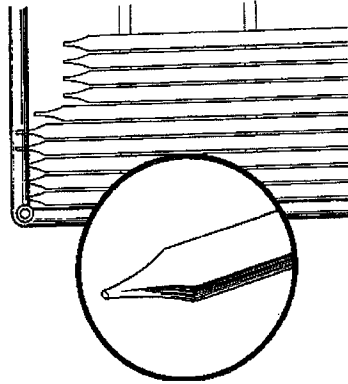

Figure 3.55 Holes-fixed Plate-1

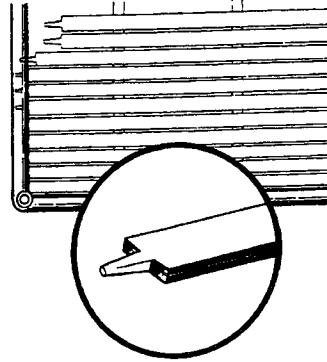

Figure 3.56 Holes-fixed Plate-2

*b. Slit-fixed plate*

The slit-fixed plate is formed by inserting ends of bamboo strips into the slit-mortise of frame tubes. The strips for this kind of plate should be lined up closely, without special treatment on the ends or edges at the side of bamboo strips, but the bamboo fiber thorns should be scraped off.

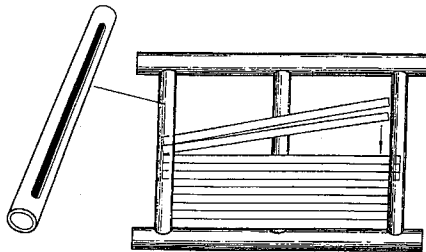

Figure 3.57 Slit-fixed Plate

The production procedure of the slit-mortise is as follows: drill one hole at either end of the slit-fixed plate inside with a hand drill. These two holes should be on the same line of the bamboo culm, and then remove the thin bamboo strip between the two holes with a sharp knife, followed by appropriate trimming and scraping, making sure that the width of the slit-mortise is equal to the thickness of bamboo strips (Figure 3.57).

*c. Pressing-fixed plate*

The pressing-fixed plate is formed by inserting bamboo strip's ends into the two overlapping bamboo culms. The bamboo frame must be solid and firm without mortise hole or slits. The production procedure is as follows: firstly make a bamboo stalk frame to fix the plate, superpose the two bamboo stalks, leaving a crevice in the between for inserting bamboo strips. Then insert the bamboo strips into the crevice, densely lin-

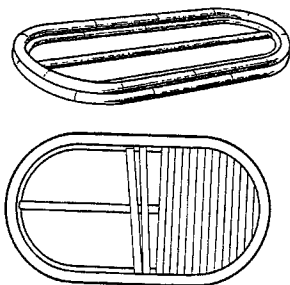

Figure 3.58 Pressing-fixed Plate

ing them up into parallel strips. Under the plate, there should be a bamboo liner vertical to the bamboo strips to support the plate. Adopt two thin bamboo stalks with the same bending curve as the bamboo stalks, as pressing-edge bamboo liners, with one liner facing upwardly, juxtaposing it with the up bamboo stalk; the other liner facing downward, juxtaposing it with the bamboo stalk below. Press tightly the edges of up and below plate respectively, and fix them with bamboo nails. Generally speaking, the top grade furniture always adopts this way of processing (Figure 3.58 and 3.59).

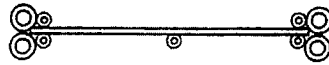

Figure 3.59 Transect of the Pressing-fixed Plate

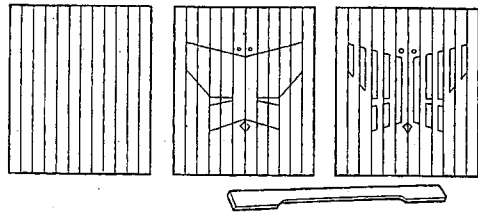

Figure 3.60 Engravings on the Plates

Engraving plates can be used to decorate top-grade bamboo furniture. This kind of engraving decoration is much easier than carving on wood furniture with more delicate effect, more lucid and compact lines. The production procedure is as follows: using pencil, sketch simple pattern on the plates lined up with parallel bamboo strips, trim and scrape one side (sometimes two sides) of bamboo strip with sharp knife, then the engraving comes into form (Figure 3.60). In addition, Ornamental figures can be expressed by using sulfuric acid or nitric acid. By carbonizing treatment on the fire, the picture will become lucid and clear-cut. Besides, painting with fire is also adopted to highlight the impressionistic effect of traditional Chinese painting.

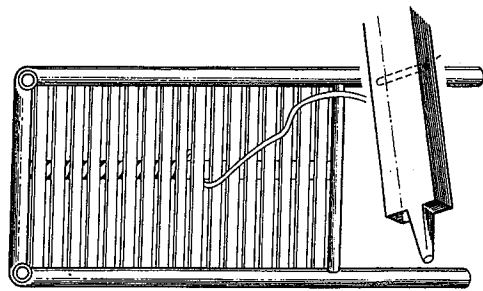

Figure 3.61 Plate Fixed with String

*d. Plate fixed with strings*

This kind of plates is fixed with a string in the middle part and dowels on both edges. The strips are strung through drilled holes on strips together with lining tube (Figure 3.61). The plates of large-size furniture needs two or three lines of strings, so at corresponding places under the plate two or three bamboo liners should be wrapped up.

#### *d. Plate fixed with strings*

Sometimes the strips can be tied firmly together with lining tube using rattan string without drilling holes.

For the above plate, since wrapping and reinforcing treatment should be carried

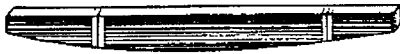

Figure 3.62 Square Bamboo Supporting Scaleboard



Figure 3.63 Semicircle Bamboo Supporting Scaleboard



Figure 3.64 Pressing Piece

out between bamboo strips, the bamboo strips should be lined up loosely.

There are lining pieces under facial plates of fragment and facial plates of strips (Figure 3.62, Figure 3.63), and pressing pieces on them (Figure 3.64). All the lining pieces and pressing pieces must be tied firmly.

Tied thin bamboo tubes and tied domino-sized bamboo pieces can be used as facial plates on armchairs or sling chairs. With the development of bamboo-based panels industry, bamboo-based panels are selected as facial plates of furniture. They are of high strength and stable size, but lacking the beauty of natural style.

### 3.3.5 Decorative Pattern on Framework of Bamboo Furniture

When the manufacture of bamboo furniture frame is completed, further reinforcement and decoration is in demand, among which an appropriate and usual practice in China is “Tuo Ya Hua Ge”, meaning different decorative bamboo patterns.

“Tuo Ya Hua Ge” is using fractures in bamboo furniture frame of small round bamboos, such as moso bamboo twigs and *Phyllostachys viridis* (Young) McClure branches, taking advantage of all the relations between the round and the square, the bending and the straight, the short and the long, the low and the high, the wide and the narrow, the dense and the loose, the concrete and the void, the deep and the shallow, decorate and fasten together various bamboo patterns with tenons, highlighting small frames on large ones. This kind of “Tuo Ya Hua Ge” can not only prevent the bamboo furniture frame from losing its original shape, but also enrich it with ethical style, enhancing its delicacy.

The use of “Tuo Ya Hua Ge” makes bamboo furniture form a sharp contrast while boasting a utility, and it also enriches the decorating styles of bamboo furniture. The patterns of “Tuo Ya Hua Ge” are rich and colorful. These in common use are case of Chinese character Mi, case of Chinese character Shou, case of foot-link, case of icy quincunx, etc., and usually adopted by top-grade bamboo furniture (Figure 3.65 – 3.87). The production requirement for manufacturing “Tuo Ya Hua Ge” is relatively high and complex. Making various cases shares some similarities but also differs from one another, so the production procedures should be carried out based on its own design.

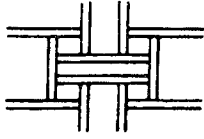

Figure 3.65 Case of Foot-link

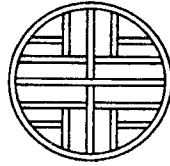

Figure 3.66 Case of Chinese Character Shou

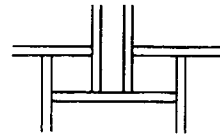

Figure 3.67 Ringer Case

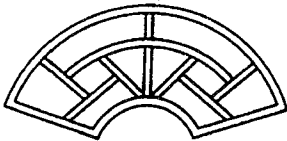

Figure 3.68 Fan-shaped Case

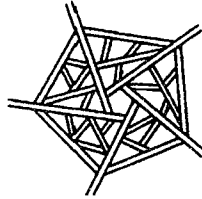

Figure 3.69 Case of Icy Quincunx

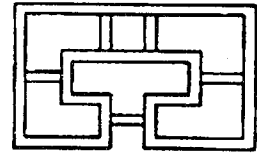

Figure 3.70 Case of Ruyi

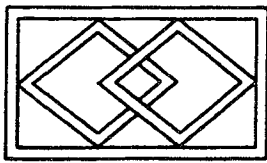

Figure 3.71 Case of Overlapping Diamonds

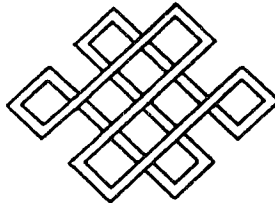

Figure 3.72 Case of Entwined Intestine

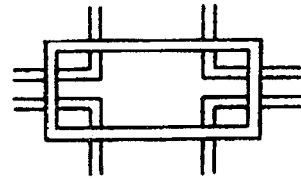

Figure 3.73 Ringer Square Case

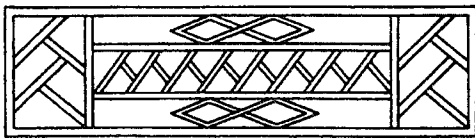

Figure 3.74 Case of Diamond and Chinese Character Ren

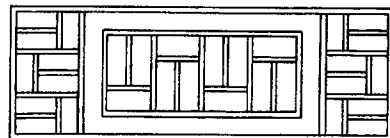

Figure 3.75 Case of Quadrate Roads and Bridges

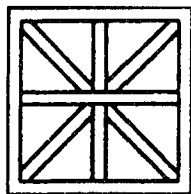

Figure 3.76 Case of Chinese Character Mi

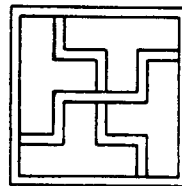

Figure 3.77 Case of Chinese Character Wan

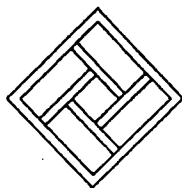

Figure 3.78 Bevel Case

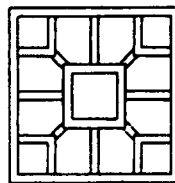

Figure 3.79 Case of Tortoise's Shell 1

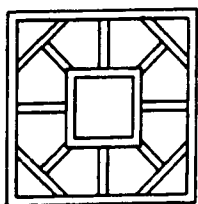

Figure 3.80  
Case of Tortoise's Shell 2

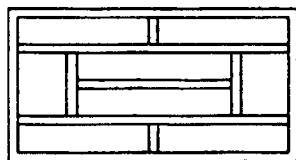

Figure 3.81 Case of Horizontal  
Roads and Bridges

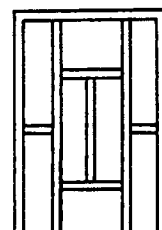

Figure 3.82 Case of Vertical  
Roads and Bridges

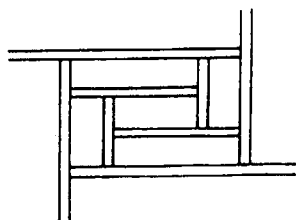

Figure 3.83 Ringer Square Case

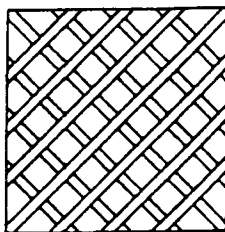

Figure 3.84 Diagonal Square Case

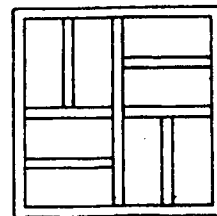

Figure 3.85 Case of Square  
Roads and Bridges

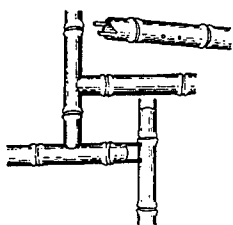

Figure 3.86 Insertion and Joining with  
a Tenon of Round Bamboo 1

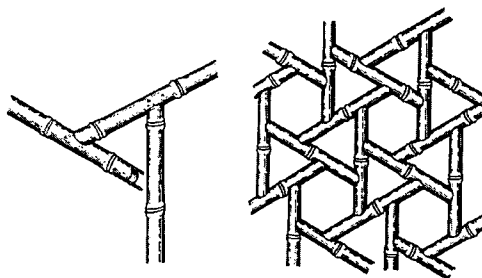
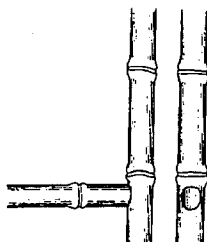

Figure 3.87 Insertion and Joining with a  
Tenon of Round Bamboo 2

### 3.3.6 Making of Traditional Round Bamboo Furniture

This section introduces the methods of making some typical traditional round bamboo furniture, such as the stool, the chair, the table, the cabinet, the shelf and the bed.

### 3.3.6.1 Bamboo stool

Bamboo stools are a kind of traditional bamboo furniture with comparatively simple structure. The bamboo stool in Figure 3.88 is a case in point. Its skeleton and four feet are all single bamboo culms without any sustaining tubes, thus saves much labor and raw material. What needs to pay attention to when making it is that big bamboo culm should be selected to make single skeleton so that it can bear a certain amount of heavy load.

The bamboo stool showed in the Figure 3.88 is 30cm long, 22cm wide and 30cm high. There are three steps to make it:

The first step is to make the stool surface. Select two skeleton bamboo culms 30cm in length and 4cm in diameter and drill 3 mortise-holes 2 – 3cm in diameter on the culm with one hole in the middle, the other two at the two ends of the culm, 6cm from the tip of the end respectively. Then take three bamboo culms 21cm in length respectively, whose diameter is the same as that of the hole. Tenon them with two skeleton bamboo culms to make a seat shelf (Figure 3.88). Notice the in-board sides of the two bamboo culms on the left and right hand should be tenoned so that bamboo strips can be inserted and thus the stool surface is made. Since the surface is small and bamboo strips are short, internodes can be used to make the surface and thus bamboo nodes can be avoided appearing on the surface.

The second step is to make the legs of the bamboo stool. Take two bamboo culms 80cm in length and 4cm in diameter respectively. Drill two square holes on each culm to tenon the ends of the seat shelf. When making the legs, the four ends of the shelf and the two square holes of the two bamboo culms should firstly be serially numbered. Measure the precise perimeter of each culm end's circle. Drill four square holes in order on two bamboo culms. Tenon four ends into these holes so as to make them strong and solid. From the square holes to the ends of the bamboo culms are called as the legs of the bamboo stool. In order to avoid its falling apart, cords are in temporary need to fasten up the ends of the legs, waiting for being unfastened till the legs have been tenoned into the square holes. The length of four legs should be equal to each other, which is 26cm respectively.

The third step is to make the square frame of the feet. Take a thick bamboo culm about 100cm in length and 4cm in diameter. Make a square frame from it that is tenoned with the legs of the bamboo stool 5cm from the ground. Pay enough attention to the relation between spaces of the square holes and the spaces of the legs. The square frame can have either one-way connectors or two-way connectors by means of connecting the head and the end of the bamboo culm. The purpose of this square frame is to secure the legs of the bamboo stool (Figure 3.89). A bamboo stool is thus fully made after the above three steps.

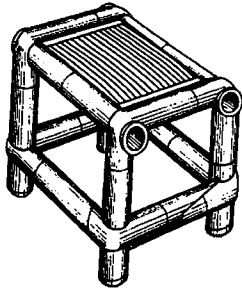

Figure 3.88 Bamboo Stool

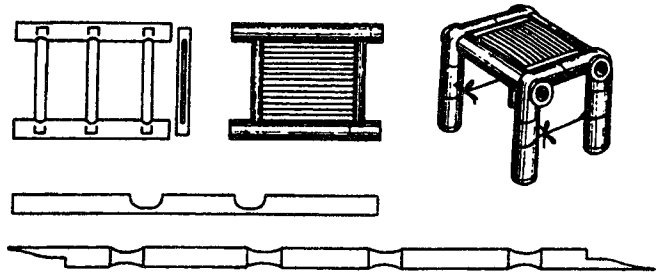

Figure 3.89 Sketch Map of Bamboo Stool Making

### 3.3.6.2 Bamboo chair

Bamboo chairs can be easily and conveniently made. They are light and solid with rich patterns. They are thus liked by consumers very much and are the most popular traditional products among all the bamboo furniture.

Figure 3.90 shows a traditional armchair that is popular among Sichuan people. Its popular name is “Paifang chair”. Both its structure and its shape are simple. Oil is applied to the surface of all the bamboo culms, which made such an armchair have strong local flavor.

“Paifang chair” can be decomposed into two composing parts. The bottom half is a square bamboo stool and the up half is arms with a back. There are thus two steps to make a “Paifang chair”.

The first step is to make the square bamboo stool. The making method of the square bamboo stool is similar to the one introduced in the previous section. Its usual length is 50cm, width 45cm and height 40cm. When making it, notice that the legs of the bamboo stool should be made slightly stretched outwards so as to enlarge the center of gravity and thus to make the chair stand steadily.

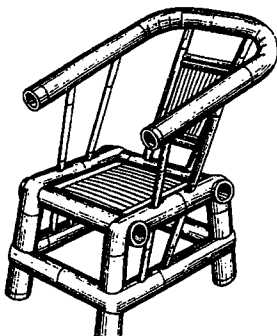

Figure 3.90 Armchair

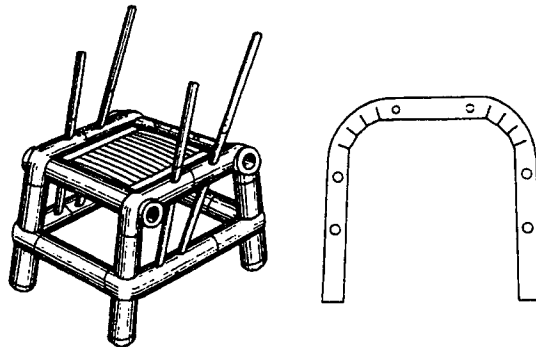

Figure 3.91 Sketch Map of Armchair Making

The second step is to make the arm and the back. Take a bamboo culm around 5cm in diameter to make the arms and the back. Make four acute angle slits on the two sides of the back and bend the culm into the shape shown in Figure 3.91. Then take four bamboo culms between 2 cm and 3 cm in circle diameter. In accordance with the method shown in Figure 3.91, first make two pairs of them with each culm having the equal size as the other in each pair. Fix them as bamboo liners into the skeleton bamboo culms that are on the two sides of the bamboo stool, making their heads leveling with each other. Short bamboo liners are arranged on the front, while long bamboo liners are arranged on the back. They are symmetrical to each other. Through the skeleton bamboo culms for the surface, insert them into the empty cavity of the bamboo culms for the frame till they reach and press tightly the inside wall of the bamboo culms. Next, make corresponding tenons under the bamboo culm used as the arms and the back. Tenon the four slightly skew bamboo liners into them to make the elevation angle of the chair suitable with a low front and a tall back. Lastly, make the back of "Paifang chair". According to the model shown in Figure 3.91, firstly fix the two vertical bamboo liners for the back which are parallel to each other, tenoning them respectively into the bamboo culm for the arms and the skeleton bamboo culm along the back of bamboo stool surface. Then fix two horizontal and parallel short bamboo liners between the vertical liners. These two horizontal bamboo liners are used to secure the surface of the back. Make tenons in them and insert bamboo strips with suitable length that are closely arranged. The surface of the back is thus formed and the whole "Paifang chair" is also made.

Figure 3.92 shows another kind of traditional bamboo chair which is common in the south of the Changjiang River. Its making is comparatively easy. The seat surface is 38cm in length, 32cm in width and 36cm in height. Its back is 38cm high. Its making method is similar to that of "Paifang chair", which also includes bamboo stool making and back making. It can be made with reference to the figures. It is therefore not necessary to have a detailed explanation again in this section.

### 3.3.6.3 Square bamboo table

The table with a square surface is called as the square bamboo table, which is one simple kind of tables. The average height is between 70cm and 80cm with big sizes and heavy loading. The skeleton culms for it are usually 3 - 4cm in diameter. When making it, firstly the skills of making enclosure culms that include tenoning and enclosure connecting are important. Second-

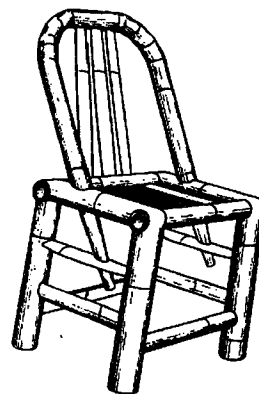

Figure 3.92 Traditional Bamboo Chair in Zhejiang



ly, reinforcement is necessary.

There are three steps involved to make a square bamboo table.

The first step is to make the skeleton of the square bamboo table. Take four straight and smooth bamboo culms in the same diameter to make the legs of the square bamboo table. Their length is between 70cm and 80cm. Then take three bamboo culms as enclosures which have the same diameter as those taken as table legs. They are taken as up enclosure, medium enclosure and bottom enclosure. Make four mouths of the square enclosure on the position of tenoning the legs of bamboo culms. The space between the mouths is decided by the width of the square table. Make enclosure connectors in the same way as what have been described in the former sections. It would be ideal if the joints of the three enclosure bamboo culms were staggered. The connectors should be single connectors and they should be made near the mouths so that the sharp point of the connector can be inserted into the inside wall of the skeleton bamboo culm which has been wrapped up by the mouth. In this way can the connectors be made firm.

The up enclosure for the skeleton of the bamboo table is used to put on and fix the bamboo strip table surface, therefore, connector pins are usually employed to connect the ends of the enclosure in order to secure the smoothness of the table surface.

There should be bamboo nodes on the up end of legs. Without them, the tenoned mouths are easily broken by pressure. Connector pins should be added to the empty inside of the up end where there are no nodes to support. Connector pins can be made of either wood or bamboo. Make them firmly against the inside wall of the up end so that it will not be squashed under pressure.

When making the skeleton of the square table, firstly tenon the first enclosure bamboo culm with the four legs. Before tenoning them, number the mouths on the enclosure bamboo culm and the legs. Then tenon them in order. The perpendicular relationship should be maintained between them. After each mouth and the end of each leg have been tenoned, secure with bamboo nails.

With the same method, tenon the second and the third enclosure bamboo culm with the legs respectively. Notice the second enclosure bamboo culms should bear against the first one so that they can be coupled tightly. Next, secure with oblique bamboo nails.

The third enclosure bamboo culms should be made 15cm apart from the second bamboo culm. Then secure with bamboo nails (Figure 3.93).

The second step is to reinforce the skeleton of the square bamboo table.

The following three measures can be taken to reinforce the skeleton.

a. Since the table surface will be put on the first enclosure bamboo culm, four comparatively slim bamboo culms should be made as bamboo liners which are in the

same length and parallel to each other. Two of them should bear against the inboard side of the enclosure bamboo culm and the other two should be fixed in the middle to support the bamboo strips of the surface (Figure 3.94).

b. Fix two upright short bamboo liners between the second and the third bamboo culm. Either half wall tenons or level tenons can be used to tenon the bamboo liners (Figure 3.94).

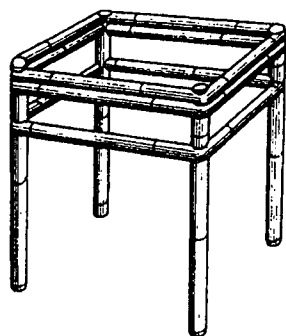

**Figure 3.93** Framework of Square Bamboo Table

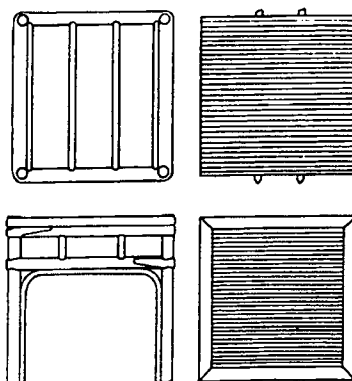

**Figure 3.94** Sketch Map of Square Bamboo Table Making

c. Since the distance between each leg of the bamboo table is comparatively far, a bamboo culm should be applied as a liner with the shape of “Yue Gong Door”. Yue Gong door is a kind of traditional Chinese door. Try best to keep the straight part of the liner longer so that the combining parts of the liner, the legs and the third enclosure bamboo culm can be increased. With the support of “Yue Gong Door” bamboo liner which is one of the methods frequently employed in making bamboo furniture, not only the skeleton can be reinforced, but also the decorative element of the bamboo table is enhanced (Figure 3.94).

The third step is to make the surface of the bamboo table.

Since the surface of the bamboo table is comparatively big, large-sized bamboo culms should be selected and processed to make bamboo strips. Then pass the tips of the strips through splits in the first enclosure bamboo culm to connect and arrange closely the strips to make the table surface. The size of the surface should be slightly smaller than the size of the square formed by the first enclosure bamboo culm. The bamboo strips should be made perpendicular to the bamboo liners. The tips of the bamboo strips should bear tightly against the up half of the inboard side of the enclosure bamboo culm and the four bamboo liners should bear tightly against the bamboo strip surface. Next take four bamboo strips 4.5cm in width with the length same as that of the table surface side. Make their tips at an angle of 45 degree. Put

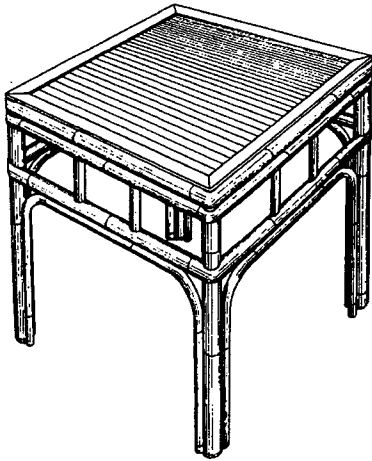

Figure 3.95 Square Bamboo Table

and press them on the four side of the bamboo strip surface to make them level with the table sides and finally firmly secure with the bamboo nails onto the first enclosure bamboo culm (Figure 3.94). A square bamboo table is thus successfully made (Figure 3.95).

#### 3.3.6.4 Bamboo cupboard

Cupboards made from bamboo are usually square with various shapes. However, their structures are much the same. Bamboo cupboards' sizes should not be too big due to the fact that bamboo is round and hollow inside and thus its loading ability and fine workmanship ability are not as

strong as those of wood.

Figure 3.96 is a sketch map of making an often-used bamboo cupboard. There are three steps involved in the making.

The first step is to make the skeleton of the bamboo cupboard.

Take four bamboo culms 2 – 3cm in diameter with the same length to make the four columns of the cupboard. Fix the positions in advance and number them serially so as to facilitate the making of enclosure bamboo culms and to assure the snug fit of tenoning.

In accordance with the size of the cupboard, take four enclosure bamboo culms in similar diameter to that of the column bamboo culms. Make mouths on them and number them in line with the serial numbers of the columns. The mouths should be made in strict proportion with the perimeter of each column where they are wrapped up. Tenon firmly on the two ends of the four columns respectively and tightly combine the two up and two bottom enclosure bamboo culms respectively (Figure 3.96). The joints of the four enclosure bamboo culms should be respectively made on the two sides of the cupboard, i. e. on the short sides of the enclosures and make the joints staggered.

Then right in the middle of the front and the back of the bamboo cupboard's skeleton, erect two level bamboo liners. Next take two bamboo culms to tenon the upright level bamboo liners in the middle. Only two mouths need to be made on these two enclosure bamboo culms with ends being tenoned into the middle point of the two columns. On the outboard side of the columns where the positions of tenoning are made, two more combined short bamboo liners should be installed. The functions of these liners are not only to support the bamboo strip surface on the side of the cupboard, but also to support the small surface in the cupboard where varia

can be put (Figure 3.96 A).

The second step is to make the legs of the cupboard.

Firstly, install two level bamboo liners in the bottom of enclosure bamboo culms of the skeleton. The positions of the two liners should not be either too close to or too apart from each other, considering the bamboo cupboard's center of gravity. The legs are made from two thick bamboo culms. On each culm, two "five-side enclosure" mouths are made. The legs are tenoned with the two bamboo liners on the bottom. The length of each mouth is approximately equal to  $1/2$  of the perimeter of the bamboo liner on the bottom because the two ends of these two enclosure bamboo culms cannot be joined together and the legs of the cupboard actually obliquely stretch outward. To secure the legs and tenoning, two fully-tenoning bamboo culms should be used, respectively tightly tenon the two pairs of legs. In addition, combined bamboo liners are installed among the four legs to further reinforce them (Figure 3.96 C, D). If conditions permit, rattan peels can be used to tie them up.

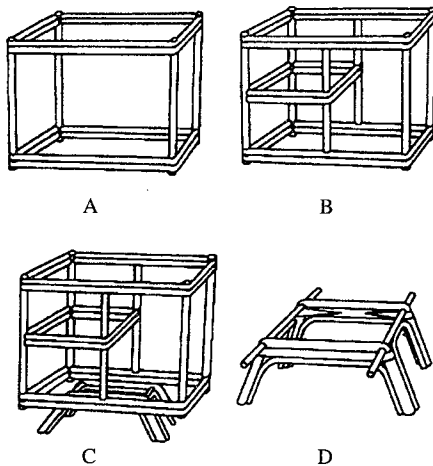

**Figure 3.96** Sketch Map of Bamboo Cupboard Making

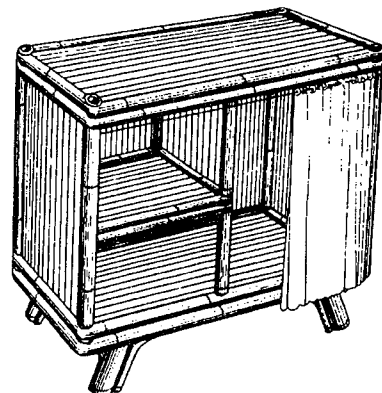

**Figure 3.97** Bamboo Cupboard

The third step is to make the bamboo strip surfaces of the bamboo cupboard.

Firstly install bamboo liners to support the bamboo strip surfaces that include the back, the two sides, the up surface and the bottom of the cupboard skeleton, and the partition and the small surface for varia in the cupboard. The length and the number of bamboo liners are decided according to the size of each surface and the need to support each surface. The liners should be installed on the long side of each rectangular surface.

Since there are so many surfaces with bamboo liners of a cupboard and each surface has different size, the lengths of bamboo strips should also have corresponding changes. Take the cupboard illustrated here as an example. It has six surfaces.

If the partition is drawn in it, then there are seven surfaces totally. All the tips of the bamboo strips are installed on the short sides of each surface, therefore, the length of the bamboo strips, not counting the length of the part being tenoned, should be equal to the length of the long side of each surface.

The bamboo strips of the cupboard's surfaces should be arranged tightly. They can be assembled either by employing level tenoning slots or by employing tenoning heads and tenoning holes.

As a rule, bamboo cupboards are not equipped with doors because bamboo timber is not sturdy enough to be made as doors and is easily damaged. Instead, curtains made from soft textiles are commonly used (Figure 3.97).

### 3.3.6.5 Bamboo bed

Beds made from bamboo culms are cool to sleep in and they are the most commonly used furniture in summer by southerners in China. As time goes by, bamboo beds will gradually turn red and glow because of the soaking of sweat, which is also the reason why users like them so much.

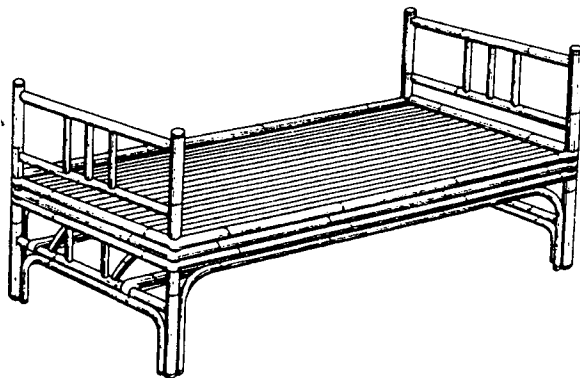

Figure 3.98 Single Bamboo Bed

Bamboo beds are big furniture with heavy loading, therefore there are more single bamboo beds than double bamboo beds. To make double bamboo beds, further reinforcement is needed. Figure 3.98 shows a single bamboo bed that can be made by three steps.

The first step is to make the skeleton of the bed.

Take four bamboo culms 5 – 6cm in diameter with the same length as the four legs of the bed. Fix the positions in advance and number them serially.

Then take six bamboo culms 4 – 5cm in diameter with the same length, each three as a set, to tenon the two pairs of bed legs, which means only two square enclosure mouths need to be made on each bamboo culm. The wrapping skin around the mouths can be left comparatively thick in order to wrap around the two legs. The ends of the enclosure bamboo culms are butted where connector pins are made as joints. Notice these joints should be staggered so that they are not on a vertical line. Thus three combined square enclosures of the four legs are made. Secure with long bamboo nails (Figure 3.99).

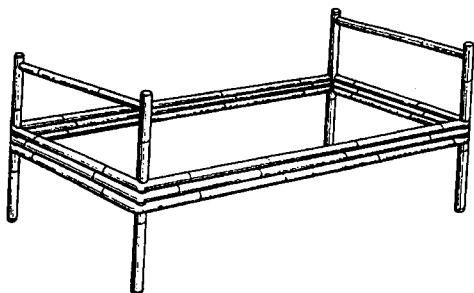

**Figure 3.99** Framework of Bamboo Bed

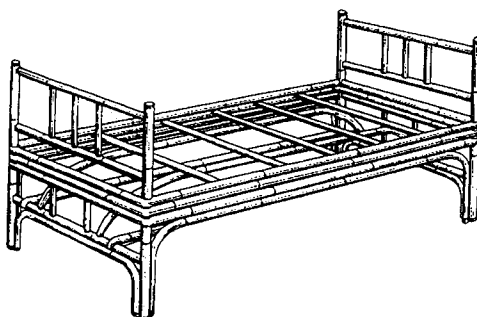

**Figure 3.100** Reinforcement of Bamboo Bed

The second step is to reinforce the skeleton of the bed.

Select the bamboo culms with thick bamboo wall 4cm in diameter as the transverse level bamboo liners of the two bed ends. Then select similarly strong bamboo culms to make the long bending “Yue Gong Door” bamboo liners for the skeleton. Combine the two rectangular “Yue Gong Door” liners in the front and the back of the bed with the legs and the bottom enclosure bamboo culm. Then combine the two transverse “Yue Gong Door” liners with the legs. The functions of the “Yue Gong Door” liners are very important. They not only enhance the loading ability of the legs and secure the perpendicularity of the four legs, but also help keeping the three combined enclosure bamboo culms in their original place. Their falling can thus be avoided (Figure 3.100).

Whittle eight semi-circle bamboo liners 4cm in diameter, respectively tenoning transversely into the rectangular holes in the bamboo culms of the bed surface to make the bed surface skeleton.

Choose two strong long bending bamboo liners to hold under the transverse semi-circle bamboo liner on the bed surface. The two long bending bamboo liners should be made from the small-sized bamboo culms so that they are easy to be heated to bend. Tenon and join them with the transverse bamboo liners under the bed crosspiece and make them tangent with each bamboo liner on the bed surface. Secure the tangent points with bamboo nails. The tenoning joints must be firm and tight because the support of these two long bending bamboo liners to the bed surface is indispensable.

The third step is to make the bamboo strip surface of the bed.

Bamboo strips should be made from large-sized bamboo timber since the surface of the bed is comparatively big. Arrange them closely and tightly by means of drilling holes and passing threads through. Put them on the eight semi-circle bamboo liners. The four sides of the surface are made with wide bamboo strips, in the same way as in making the surface of a square bamboo table. The other way is to use bamboo liners to press down the surface. What should be noticed is that the wide

bamboo strips which are used to press down the four sides of the bed surface should be combined together with the up enclosure bamboo culm of the bed surface skeleton (Figure 3.98). A bamboo bed is thus made.

Figure 104 shows a kind of simple bamboo bed frequently used in the country and town in the south of Yangtz River. It is 190cm long, 72cm wide and 46cm high. All the skeleton bamboo culms are single, so the bamboo culms for the skeleton should be large with 6-7.5cm in diameter and bamboo liners with 3-4cm in diameter.

The making of the simple bamboo bed is comparatively easy. Firstly, make the bed surface. Take two head parts of moso bamboo 190cm in length and 6-7cm in diameter as the skeleton of the bed surface. Respectively drill 7-8 semi-circle tenon holes with the same interval on the two sides of the bamboo culms. Whittle 7-8 semi-circle bamboo liners 70cm in length, respectively tenoning them into the holes in the two skeleton bamboo culms of the bed surface so that the bed surface skeleton is made.

Secondly, take two bamboo culms 164cm in length and 6-7cm in diameter. Dig out two square enclosure mouths on each culm. At the same time, drill the tenon holes in two ends of the bamboo liners. Then not only tenon the ends of the bamboo culms of the bed surface, but also tenon the whittled bamboo liners onto the skeleton bamboo culms. These liners include the bamboo liners both on the front and the back of the bed and the seven short upright bamboo liners already tenoned to the two ends of the bed. Secure with bamboo nails to make the skeleton strong and firm. From the mouths to the ends of the bamboo culms are the legs of the bamboo bed.

According to the length of the inboard side of the bed surface skeleton, make the bed surface from moso bamboo culms and install it in to the bed surface skeleton. Press down the two ends with bamboo tiles and secure with long bamboo nails. A simple bamboo bed is finally made (Figure 3.101).

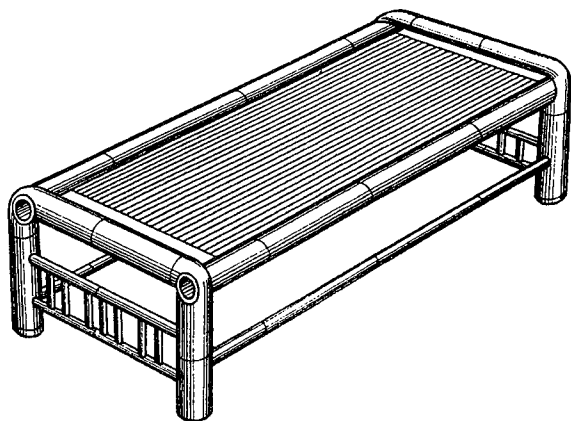

Figure 3.101 Simple Bamboo Bed in Zhejiang

### 3.3.6.6 Bamboo bookshelf and miniascape stand

It is good to make use of bamboo culms to make bookshelves and miniascape stands since bamboo culms are tall and straight, elegant and refreshing.

By employing the techniques like heating to bend and combining, skilled workers can make bookshelves and miniscape stands of various shapes. They are beautiful yet inexpensive, and thus they are very popular among people.

Figure 3.102 shows a commonly-used four-layer bamboo bookshelf. There are three steps to make one.

The first step is to make the skeleton of the bookshelf.

Take four bamboo culms to make the legs of the bookshelf. The two front legs stretch forward after being heated to bend so as to assure that the bookshelf will not lean forward and fall down. The two back legs are made perpendicular to the ground, usually leaning against the wall, without fear of falling backward. The interval between each layer can be decided according to different lengths of books. The height for each layer is usually 3cm more than the length of books. The first layer and the fourth layer of the bookshelf need two bamboo culms respectively for enclosure, while the rest two layers need only one for enclosure respectively. Tenon six bamboo culms for enclosure with four bamboo culms for the legs and connect the head and the end of each culm. The skeleton of a bookshelf is thus made (Figure 3.103).

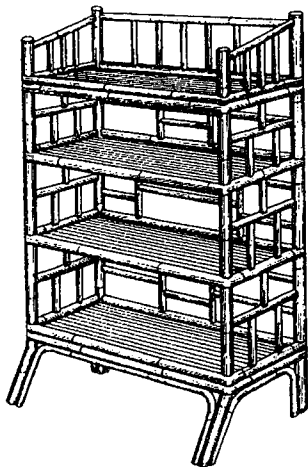

**Figure 3.102** Four-layer Bamboo Bookshelf

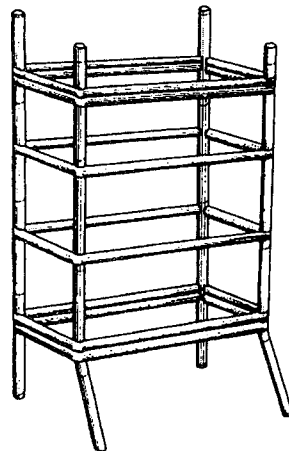

**Figure 3.103** Framework of Four-layer Bamboo Bookshelf

The second step is to reinforce the skeleton of the bookshelf.

To reinforce the skeleton of the bookshelf, four “Yue Gong Door” bamboo liners and many short bamboo liners are needed. There are no special requirements in making and installing it. Except that the bamboo liners to support the bamboo strip surface should be tenoned by half wall tenons that are comparatively firm, the others can be used for fish mouths, pointed tip tenon and oblique mouth tenon.

The third step is to make bamboo strip surface.



The making procedure is similar to those illustrated in the former sections.

Figure 3.104 shows a high-class miniascape stand. Its structure and making procedure are similar to those of a bookshelf. The slight differences are there are more changes in shapes when heating bamboo culms to bend and there are more decorative bamboo liners in the skeleton.

The height of a miniascape stand is usually above 2m. Tall and slim, when a miniascape is put on the stand, its head is heavy while its legs are light. Therefore it is very important to keep its center of gravity balanced. The ground where the stand is on should be smooth. The bending of the bamboo culms should be made in moulds in order to ensure its bending degrees are symmetrical to the central vertical line so that each stand bamboo culm is absolutely symmetrical to each other.

Enclosure bamboo culms' tenoning is usually made only on the top and the slim middle part of a miniascape stand. For those high-class stands, on the other hand, the top, middle part and the bottom of those are all tenoned with enclosures. The workmanship is strictly required. The mouths on the culms must be sawn without being inclined. The legs are reinforced usually by "Yue Gong Door" bamboo liners.

The bamboo strip surface is installed into the uppermost enclosure bamboo culm of the stand to support the miniascape put on it. Notice that most decorative bamboo liners are installed on the skeleton bamboo culms between the two sets of enclosure bamboo culms, i. e., on the chest of the stand, since here it is the focus of people's sight (Figure 3.104, 3.105).

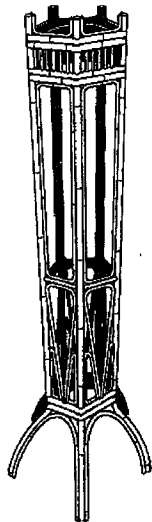

Figure 3.104 Miniascape Stand

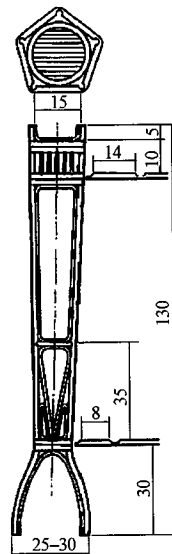

Figure 3.105 Sketch Map for Making a Miniascape Stand

The styles of traditional round bamboo furniture varies in different regions of China (Figure 3.106 – 3.118).

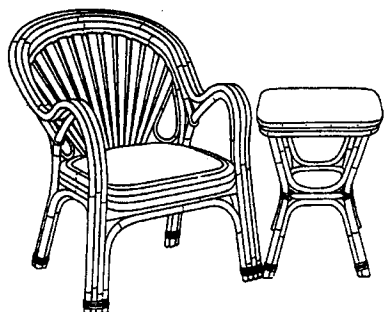

Figure 3.106 Armchair and Tea Table in Zhejiang

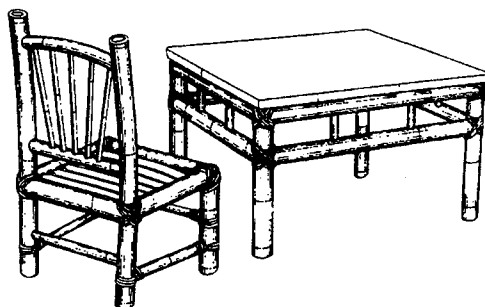

Figure 3.107 Small Square Desk and Square Stool in Suzhou

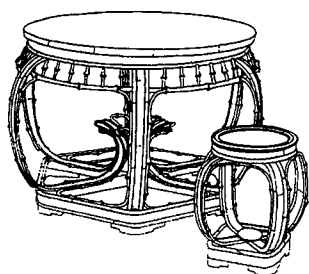

Figure 3.108 Round Table and Round Stool in Sichuan

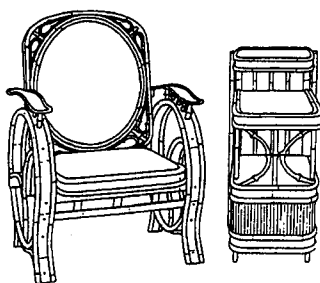

Figure 3.109 Armchair and Tea Table in Sichuan

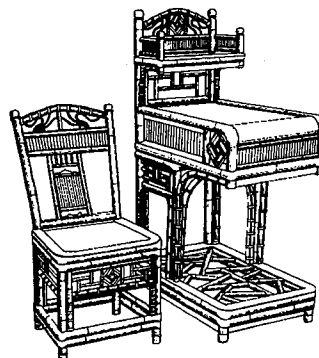

Figure 3.110 Archaized Tea Table and Chair in Hubei

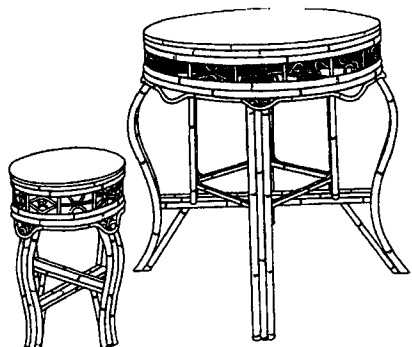

Figure 3.111 Round Table and Stool in Guangdong

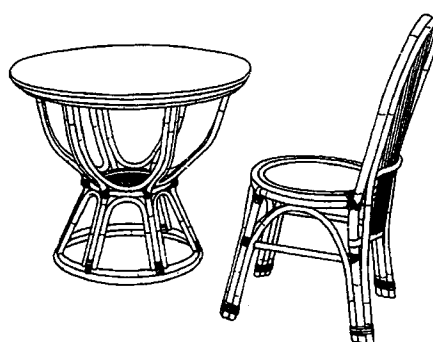

Figure 3.112 Round Table and Chair in Hunan

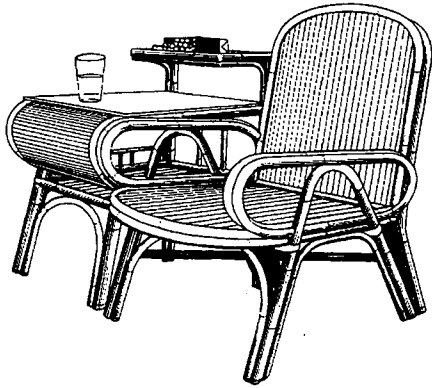

Figure 3.113 Armchair and Tea Table in Sichuan

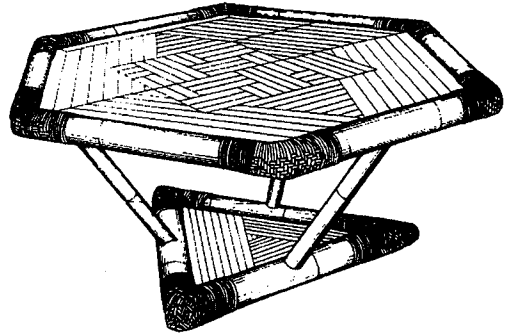

Figure 3.114 Small Hexagon Table in Jiangsu

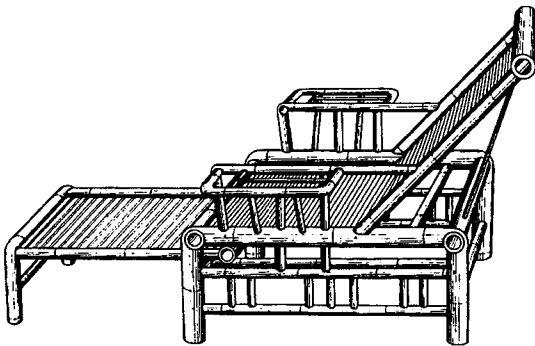

Figure 3.115 Reclining Chair in Sichuan

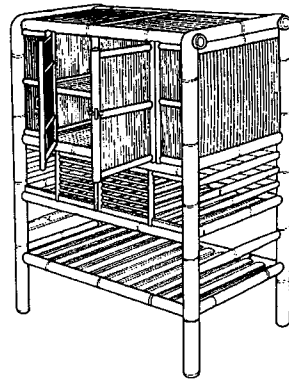

Figure 3.116 Three-layer Cupboard in Zhejiang

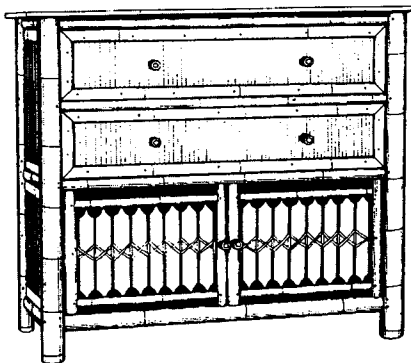

Figure 3.117 Chest of Drawers in Jiangsu

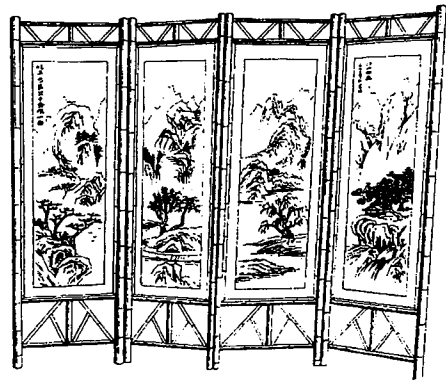
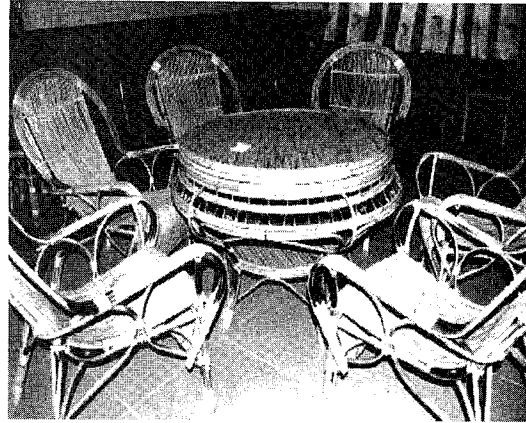

Figure 3.118 Folding Screen in Zhejiang

Following are the pictures of round bamboo furniture from different areas (Figure 3.119 – 3.127).



**Figure 3.119** Round Table and Round Stools in Zhejiang



**Figure 3.120** Round Table and Armchairs in Guangdong

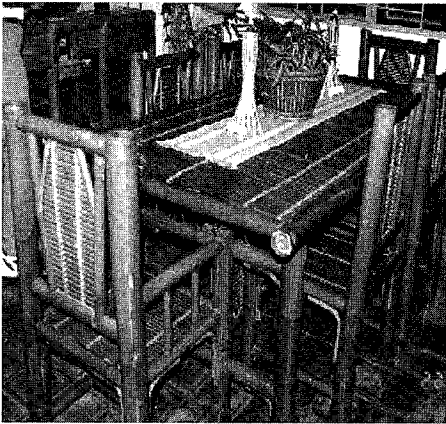

**Figure 3.121** Square Table and Armchairs in Philippine

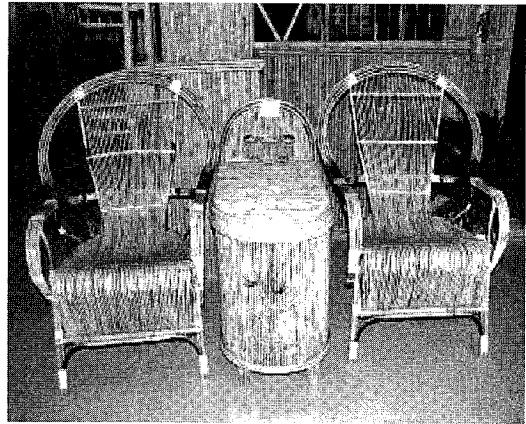

**Figure 3.122** Armchairs and Tea Table in Guangdong



**Figure 3.123** Dressing Table and Stool in Philippine

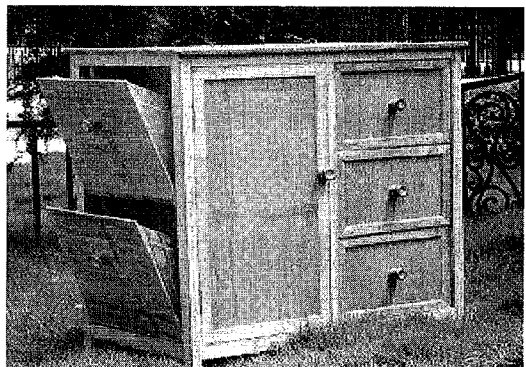

**Figure 3.124** Cupboard in Jiangsu

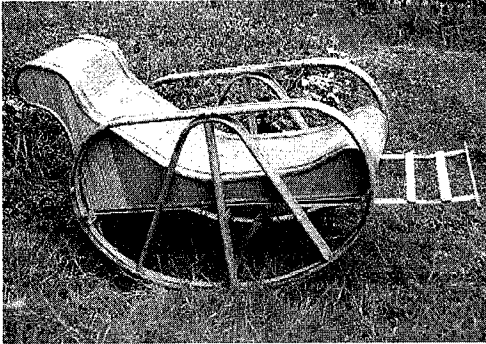

Figure 3.125 Reclining Chair in Sichuan

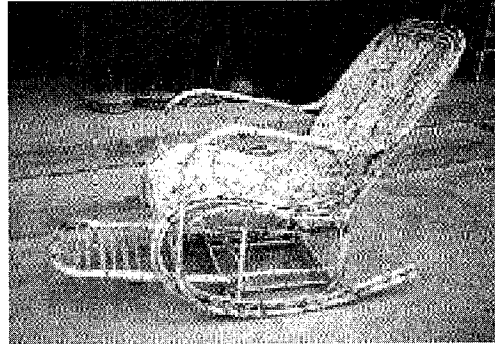

Figure 3.126 Reclining Chair in Zhejiang

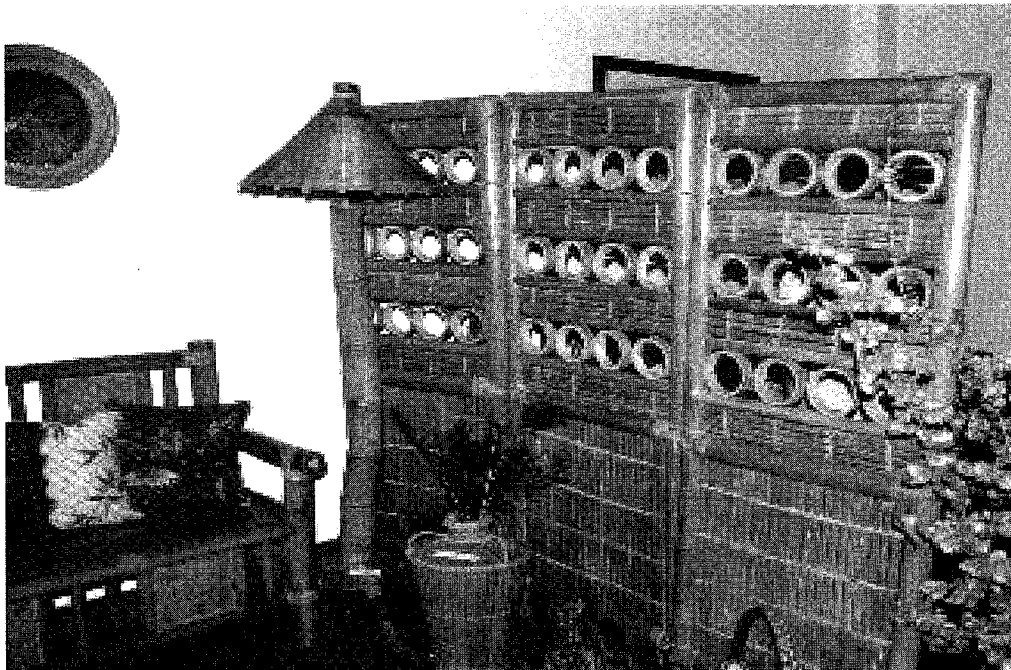

Figure 3.127 Folding Screen in Philippine

### 3.4 Laminated Bamboo Furniture

Laminated bamboo furniture, which is designed and produced in accordance with modern wood furniture, is composed of basic components such as plate, rectangle or round poles, bended parts, etc. after a series of mechanical processing procedures from the shaved bamboo strips. Therefore, laminated bamboo furniture making should be classified into the industrial processing. To have a comparison with traditional round bamboo furniture, it is briefly introduced in this section.

### 3.4.1 Laminated Bamboo

Laminated bamboo is formed of bamboo strips of pre-determined width and thickness, and is manufactured by means of culm cutting, hackling, jack plane, boiling (including bleaching, anti-insect, anti-fungus and antisepsis etc.) or carbonization, drying, finish plane, tiles selecting, glue spreading, assembling, bi-directional pressure gluing, edge sawing and sanding (Figure 3.128).

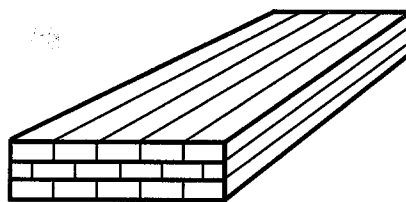

Figure 3.128 Laminated Bamboo

Its structure is same as that of combined wood. All the elements of laminated bamboo are assembled in the same direction. Its uses and functions are also similar to those of combined wood. Laminated bamboo can be classified into two categories: thinner and thicker. The thinner laminated bamboo (3 – 8mm) is mainly used for interior decoration and surface decoration of furniture.

One disadvantage of the thinner laminated bamboo is that it is prone to break when being transported or moved because it is thin and its side gluing area is small and thus the intensity in width is small too. Since bamboo strips are a kind of heterogeneous material, the stresses, shrinkage and expansion of external and inner part of bamboo culms are not equal, which also makes them easy to deform and break. Therefore, special attention is needed to prevent them from transverse breaking during the processes of edge sawing and sanding after they have been glued into shape. In addition, before its surface is painted, as a decorative material, laminated bamboo needs preserving from becoming mildewed when being stored and transported. The solution is to use plastic films to seal it up and to use packing cases to pack it.

Thick laminated bamboo can be used as construction material as well as decorative material. Therefore, there should be strict demand on material quality of and processing techniques for surface bamboo tiles when being selected. On the other hand, the medium layer and bottom layer of bamboo tiles can be chosen from inferior bamboo tiles in quality. The key to influence the final quality of thick laminated bamboo happens during the process of its bi-directional pressure gluing. Special attention is thus needed during production.

The production procedure of laminated bamboo is similar to that of bamboo floor. Its technological flow goes as follows:

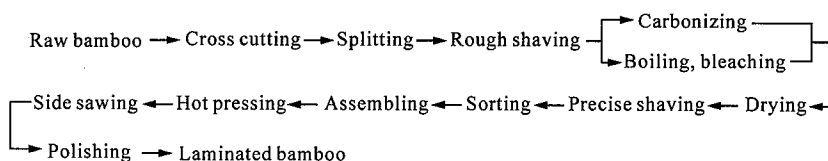

### 3.4.2 Processing Features of Laminated Bamboo Furniture

#### 3.4.2.1 Facial parts

The bamboo strips used to make facial parts for the table, stool and chair need to be rigorously selected so that there is only one color for one bamboo facial part. However, to reach special effect, by means of bleaching and carbonization in turn, color matching can be applied on facial parts when assembling and gluing.

#### 3.4.2.2 Bending-fixed parts

By making use of the flexibility of bamboo culms, the fine produced bamboo strips are cut according to demanded lengths. Glue is spread several layers on them and then they are put into different molds and are tightly clamped. By heating, the glue is solidified and then by cooling, the shapes are finalized. In mass production, multi-directional pressing machine can be used to work with molds to produce the parts.

#### 3.4.2.3 Pole parts

Thick laminated bamboo can be made into rectangular or round pillar-shaped parts through sawing or machine cutting.

#### 3.4.2.4 Linking

The parts are assembled usually by making use of tenons and metal connectors.

Figure 3. 129 – 3. 136 are different pieces of laminated bamboo furniture.



Figure 3. 129 Square Desk and Square Stools

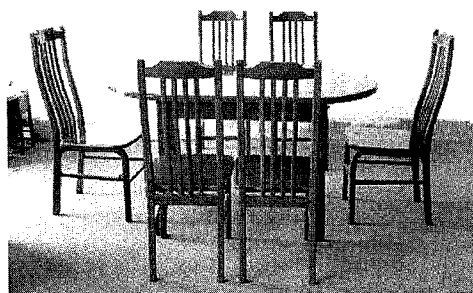
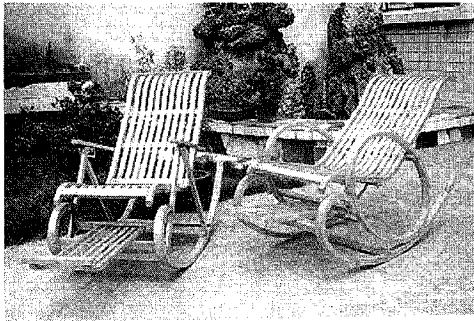
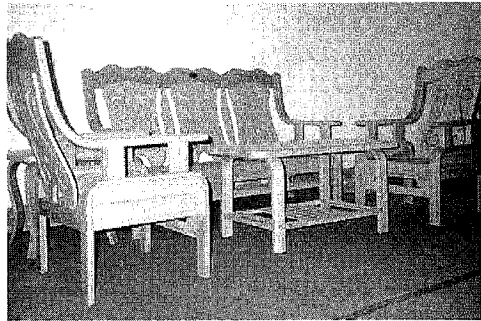

Figure 3. 130 Dining Table and Chairs



**Figure 3.131** Reclining Chairs



**Figure 3.132** Whole Set of Sofas

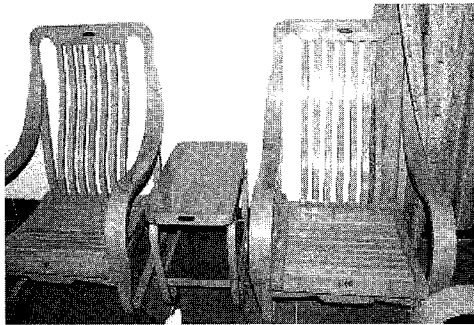

**Figure 3.133** Armchairs and Tea Table

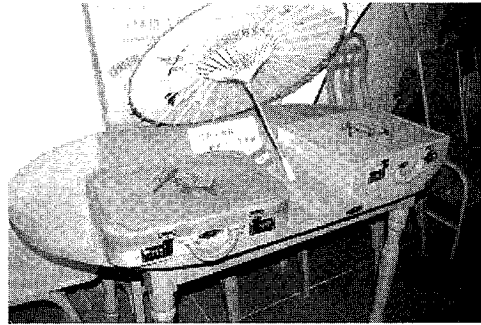

**Figure 3.134** Suitcase

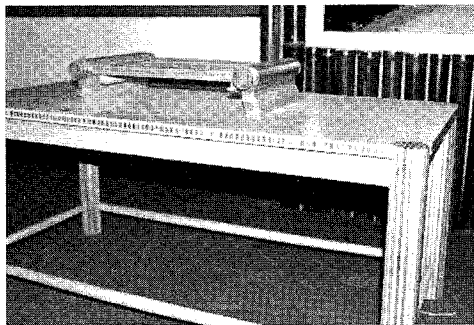

**Figure 3.135** Oblong Table

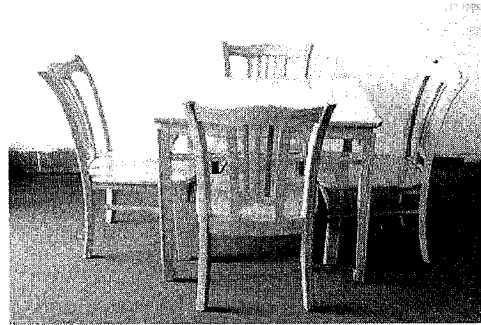

**Figure 3.136** Mahjong Table and Chairs



# CHAPTER 4

## Bamboo-based Panel

According to its basic structure components, bamboo-based panel can be divided into three categories: bamboo sliver products, such as woven-mat plybamboo, curtain plybamboo, mat-curtain plybamboo etc. ; bamboo sliver products, such as plybamboo, laminated bamboo, bamboo flooring, etc; bamboo-wood composite products, such as bamboo-wood composite plywood, bamboo-wood composite panel, bamboo-Chinese fir composite flooring, etc.

### 4.1 Woven-mat Plybamboo

Woven-mat plybamboo, starting in the 1940s and 1950s, is the earliest variety of bamboo-based panels. The production process of woven-mat plybamboo is simple and its source of raw materials is extensive. There can be little investment in building factories and high utilization rate of bamboo if we make good use of small- and middle-sized sympodial bamboos. Characteristic of comparatively high mechanical property and low production cost, woven-mat plybamboo as one of the main varieties of bamboo-based panels, is widely applied to various lines of work, like packing, furniture, construction and vehicles. The manufactories of woven-mat plybamboo are mainly located in Sichuan, Hubei, Zhejiang and Jiangxi Provinces.

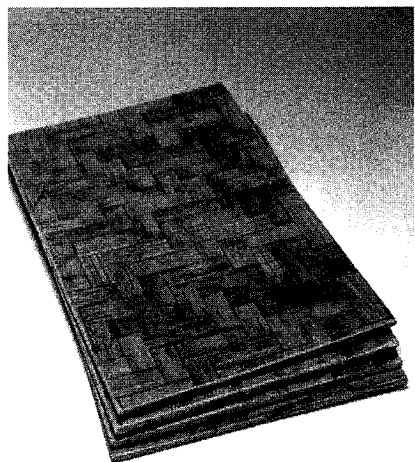

Figure 4.1 Woven-mat Plybamboo

#### 4.1.1 Definition and Assortment

The woven-mat plybamboo, is made through a series of production processes, like splitting

bamboo, weaving mat, coating (soaking) glue and hot pressing. Its outward appearance sees Figure 4. 1. The woven-mat plybamboo boasts of a wide variety. According to its use, the woven-mat plybamboo can be divided into packing box plate, railway boxcar apical plate, furniture plate, construction mold board and railway carriage base plate.

#### 4.1.2 Production Process

The technological production process of the woven-mat plybamboo is as follows:

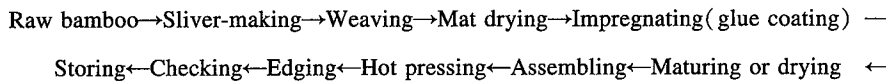

In order to meet relatively high requirements of bamboo mat, the bamboo slivers that are produced for woven-mat plybamboo used in furniture or decoration still need further processing procedures for fine woven mats, like sanding, bleaching and dyeing.

The production process varies with different final products. The woven-mat plybamboo used in packing or vehicles are made of rough bamboo mats that can be woven in the peasant households and purchased by the factories for further processing. The woven-mat plybamboo used in making furniture or decorating has to be made of fine woven mat that require the bamboo slivers to be carried on the process of sanding, bleaching and dyeing. Therefore the working procedures of making bamboo slivers and weaving mats should be arranged in the factories, if possible, so that the quality of products can be controlled. Figure 4. 2 is the rough bamboo mat and Figure 4. 3 is the fine bamboo mat.

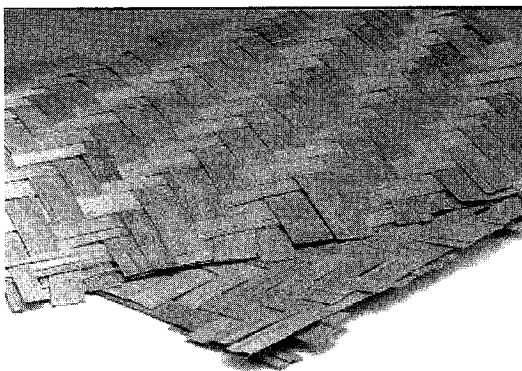

**Figure 4.2** Rough Bamboo Mat

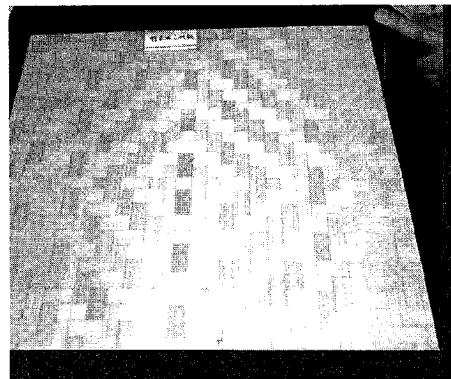

**Figure 4.3** The Fine Bamboo Mat

osswise over and under lengthwise ones. Crosswise slivers are called warps and lengthwise wefts. For weaving rough mats, warps pass over three wefts first and then under three wefts, and for making fine mats, warps pass over and under only one weft.

Those bamboo mats' quality are required to have a flat and smooth = surface, which is a rectangle and accurate pattern and whose edges should be complete and sturdy.

#### 4.1.6 Drying

The bamboo mats are mostly woven separately. Various sources of raw material result in the differences of the mat's moisture content. Besides, if the moisture content of bamboo mat is too high, the bamboo mat will be liable to go moldy and moth-eaten during storage. Therefore, the woven bamboo mats must be dried immediately so that the moisture content will be identical to meet the requirements of follow-up working procedures.

After being dried, the bamboo mat's moisture content range should be normally kept in the range of 6% - 12%. It can be higher for urea-formaldehyde resin and lower for phenol resin for ply-bamboo production.

Mats can be dried naturally or artificially. The artificial drying is of good quality and large output, which is applied to industrial production. The artificial drying mainly adopts drying kilns and drying machines. The drying kiln can choose common wood drying kiln whose heat source is steam or oven heat. Usually normal temperature kiln is chosen to carry out technological production. The drying machine of single tier or double tier for plywood can be applied to dry bamboo mats. The drying time normally lasts 10 to 15 minutes and the temperature is 140 - 160°C.

If there are no possibilities of artificial drying, bamboo mats can be dried naturally, by airing. But this method depends on the weather, the effect is not stable and can not be done in great batches.

#### 4.1.7 Adhesive Coating (Impregnating)

Mats are coated or impregnated with adhesive for hot pressing.

Urea formaldehyde resin (solid content 48% - 65%) adopts coating. The coating amount is 200 - 275g/m<sup>2</sup> for single surface and 400 - 550g/m<sup>2</sup> for double surface. The adhesive coat should be thin and even.

Phenol resin is usually used for impregnating, that is, to put the bamboo mat into a resin pond and soak them for a while, then fetch them out and extrude surplus resin from them with upper and lower rollers. Normally, when the adhesive solid content is 28% + 2% and bamboo mat's moisture content is 4% - 6%, the impregnating time can be kept in the range of 2 - 2.5 minutes; when bamboo mat's mois-

ture content is 10% – 12% , the impregnating time is 2.5 – 3.5 minutes, thus impregnating rate can achieve 6% – 7% . If other type of adhesive are applied, the impregnating time must be determined by tests. The impregnating rate is a ratio between solid matter of resin absorbed by mat and the weight of the mat itself. It is an important factor for evaluating impregnating quality. Generally speaking, if the adhering effect is achieved, the lower impregnating rate is the better. The quality of panels improves with the raise of impregnating rate, but if the impregnating rate exceeds 10% , the effect is not evident. Therefore the impregnating rate should be kept in the range of 6% – 7% .

#### 4.1.8 Maturing or Drying

The coated mats must be laid for a certain period of time in order that the resin permeates the surface of slivers and weaving crosses, and the moisture evaporates by airing. This process is called maturing. Maturing time depends on the viscosity of adhesive and the room temperature. If the viscosity is higher and temperature is lower, maturing time can be longer, otherwise maturing time can be shorter. Normally, maturing time is 20 – 60 minutes.

The impregnated mats can be laid for several hours for natural drying, but no more than 24 hours. To promote the output and quality, the mats can be dried artificially, the temperature of drying medium should not exceed 80°C and final moisture content is kept between 15% – 18% .

#### 4.1.9 Assembling

The bamboo mats are woven of wefts and warps, and the mechanical property of crosswise and lengthwise are quite similar. Thus when assembling, Mats woven their mechanical properties. Therefore they can be assembled not only in odd number, but also in even number.

The two sides of assembled sets should be covered with a metal plate respectively to avoid the possible pollution of platens and the mat surface.

If metal plates stick to mat surfaces upon unloading, it is recommended to smear ungluing agent on the plates to separate the metal plate from bamboo mat board.

#### 4.1.10 Hot Pressing

The hot pressing indexes of woven-mat plybamboo are shown in Table 4.1. To further solidify the adhesive inside the plybamboo, they should be piled up in order (called heat stack) after the unloading from pressing machine. The heat stack also helps to eliminate the plybamboo's internal stress and reducing deformation.

---

**Table 4.1 Hot Pressing Indexes of Woven-mat Plybamboo**

Adhesive Types	Temperature (°C)	Pressure unit (MPa)	Hot pressing time( minute)			
			Double-l	Triple-l	Quadruple-l	Penta-l
Phenol resin	140 – 150	2.5 – 4.0	3 – 4	5 – 7	8 – 12	10 – 15
Urea – formaldehyde	110 – 120	2.5 – 4.0	3 – 4	4 – 5	5 – 7	6 – 7

#### 4.1.11 Edging and Checking

After 12 – 24 hours' heat stack, the hot pressed panels can be cut in crosswise and lengthwise directions according to the product standards or the requirements of customers. The dimensions and tolerances, appearance, physico-mechanical properties of panels are checked after cutting. Then they are packaged and stored.

#### 4.1.12 Physico-mechanical Property

Physico-mechanical property depends on adhesive types, hot pressing technological conditions, number of layers and thickness of panels. The MOR of thinner panels can be >90MPa. The MOR of thicker panels is lower than that of the thinner ones of the same sort and with the same adhesive. Samples of woven-mat plybamboo can hardly be gripped firmly; their adhering strength cannot be tested as usual plywood. To solve this problem, the samples of products are treated in the way of "boiling (impregnating) - freezing - drying", and then their MOR is tested.

## 4.2 Curtain Plybamboo and Mat-curtain Plybamboo

### 4.2.1 Definition, Classification and Usage

Curtain plybamboo is made of bamboo curtain while mat-curtain plybamboo is made of bamboo mat and curtain. Impregnated with adhesive (generally phenol resin), the curtains and mats are hot-pressed into bamboo-based panels according to requirements of usage, glue-soaking.

Curtain plybamboo is mainly used as primary material to be covered with a surface of high strength for making concrete forms. Mat-curtain plybamboo is made of bamboo mats as surface layers and bamboo curtain as core layers, which can be divided into "thick curtain" and "thin curtain" according to the thickness of curtains.

Mat-curtain plybamboo is mainly used for common concrete molding board, which only calls for a roughly smooth surface. Comparing with traditional materials for making concrete form, such as steel, wood and plywood, mat-curtain plybamboo has large dimensions, higher rigidity and strength. It is widely used in tier

building, engineering establishment and industrial workshop where concrete is molded on the spot of construction and surface decoration is in demand by cement after being unmolded. Currently, it has the largest output among all the man-made bamboo boards. Its appearance refers to Figure 4.5.

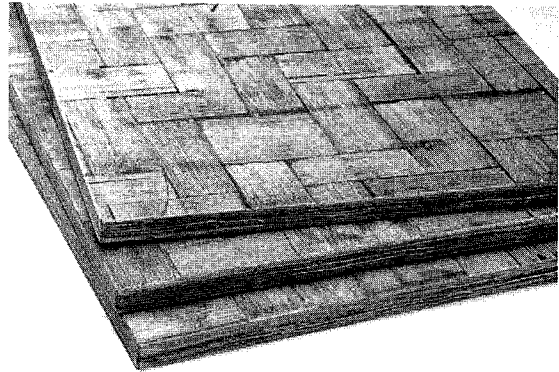
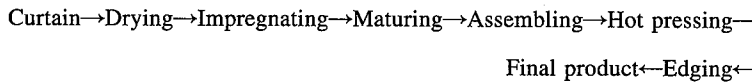

Figure 4.5 Appearance of Mat-curtain Plybamboo

#### 4.2.2 Production Process

The technical process of the curtain plybamboo is as follows:



The technical process of the mat-curtain ply-bamboo is as follows:

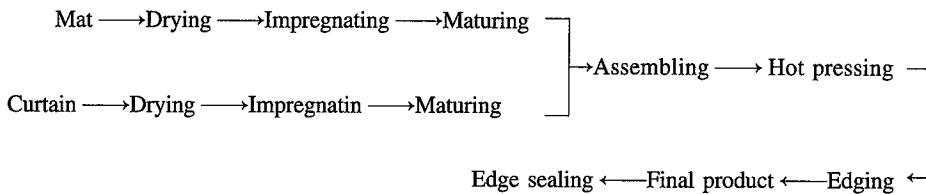

#### Raw material

The curtains for making plybamboo are about 1mm in thickness. The sliver making and curtain-weaving are all conducted by machines. The strips are densely arranged and the thickness of curtain is uniform. The mats for making mat-curtain plybamboo are similar to those used for making woven-mat plybamboo. “Thin curtain” are made of slivers about 1mm in thickness, with warp threads of terylene, which are about 300mm between two adjacent warps; The “thick curtain” is made of slivers about 2 – 3mm in thickness. The bamboo curtain is required to be flat, solid and always in good shape and the strips within should be densely distributed without overlapping.

The curtains used for making mat-curtain plybamboo are mostly woven and dried by individual peasants in bamboo region. After preliminary drying, it is purchased and mass processed by factories. The bamboo curtains for making contain plybamboo requires higher quality, so the sliver-making and curtain-weaving are always completed by mechanical equipment in the factories to take control of the gap

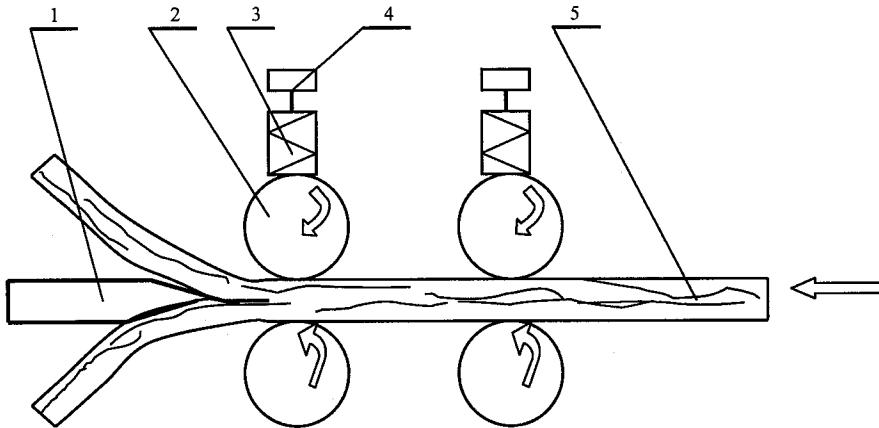

**Figure 4.6** The Work Principle of Strip-cleaver

1. Cleaver for splitting bamboo strips
2. In-input roller
3. Pressing spring
4. Pressure-adjusting bolt
5. Bamboo strips

between strips and thickness error. The work principle of strip-cleaver (single edge), the main equipment for making strips, refers to Figure 4.6.

#### 4.2.3 Drying

Bamboo mats and curtains must be dried to reduce their moisture content to less than 12% before impregnating. They are dried as those for making plybamboo.

#### 4.2.4 Impregnating

It needs to take a large amount of adhesive if it is applied to coat curtains because there are many pores and chinks in them. So impregnating is put into use. The curtains and mats are loaded vertically in steel cages and dip cages into an adhesive pool by an electric hoist. After 2–4 minutes, hoist the cage, move to the place above dripping tank. The impregnated curtains and mats are to be dried or matured as those used for making woven-mat plybamboo, because they are also moisturized by adhesive in the process of impregnating.

#### 4.2.5 Assembling

Bamboo mats are applied as surface layers, while curtains as core layers. The number of layers and the arrangements of crosswise and lengthwise curtains are decided in accordance with the uses of products and strength requirements. The structure must be symmetrical for the stability of dimensions. The structure of mat-curtain plybamboo is shown in Figure 4.7. one crosswise curtain is piled on one lengthwise curtain alternately. It is also permitted to pile several crosswise curtains on several lengthwise ones alternately. In such cases several crosswise curtains or several

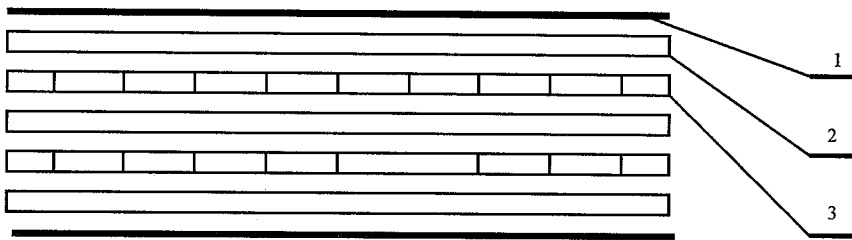

**Figure 4.7** Transect of Mat-curtain Plybamboo  
1. Bamboo mat 2. Lengthwise curtain 3. Crosswise curtain

lengthwise curtains are regarded as one layer.

#### 4.2.6 Hot Pressing

The whole process of hot pressing can be divided into three stages.

Stage 1: from placing the first sheet of mats on hot-pressing board to the consolidation of all the hot-pressing boards and reaching the pre-determined unit pressure. This stage is also called free heating period.

Stage 2: from achieving the pre-determined unit pressure to the start of reducing the pressure. This stage is also called pressure maintaining period.

Stage 3: from the start of reducing the pressure to splaying of all the hot pressing boards. This stage is called pressure reducing period.

At the first stage, before being pressured, the down side of assembled mats is heated when comes into contact with the hot pressing board, so the heated bamboo slivers gets dry and shrinking, and the adhesive may get somewhat solidified; on the other hand, the up side of the mats is heated by the hot air, which is much slower than the down side. The difference in heating between the up side and down side will affect the quality of agglutination, and will lead to adhesive unglued, crooked or deformed. So in order to make sure the quality of agglutination, the free heat period should be as short as possible. For the hot-press that requires manual work in loading board, the layers are 10 at most and the free heating period lasts no more than 1 minute. For 10-layers-above hot press, it should be completed with load and unload equipments to shorten the free heating period.

During the pressure maintaining period, changes inside veneer sets are quite complex, which include the change of moisture content and temperature, change inside the bamboo, solidification of adhesive after its shrink and polymeric reaction. These three types of changes gradually take place one after another or simultaneously.

During the free heating period, quite a little moisture vaporizes (usually about 1%) because only some parts of it receive thermal radiation and contact heat. While during the pressure maintaining period, the temperature of veneer sets goes up regu-



larly as a result of simultaneous heating and pressing, which speeds up the movement of the water inside it. Meanwhile, some water changes into steam. Because steam is more pervasive than water, and the volume of air inside bamboo material expands due to the heating, the steam expands to the peripheral parts of assembled veneers. As the hot pressing continues, the bamboo material is gradually compressed and compacted, and the adhesive solidified, which hinders the flow of moisture and steam. Then the steam pressure inside bamboo materials rapidly increases, so does the temperature of the bamboo materials. Moisture in peripheral part easily gets vaporized and the air around helps cool down, so the temperature in this part maintains at 100°C for a certain period, while the temperature at its center will gradually reach the height of hot pressing board.

When the temperature gradually increases with the hot pressing continuing, a remarkable temperature difference comes into being between the peripheral and central area of the veneer sets. The peripheral part of veneer sets is of lower temperature, its area depends upon the water content of veneer sets, heating temperature and surrounding air. According to concerned information, the low temperature area of periphery is about 75 – 150mm. The expansion of steam from central part is blocked, which raises the temperature of bamboo material in central part, forming a high temperature area. In that area, there are a massive amount of steam and over-heated moisture that fails to change into steam. That's why the moisture in central high-temperature area is far more than the peripheral low-temperature one.

During the hot pressing, two kinds of deformations occur: elastic deformation and plastic deformation. Elastic deformation happens mainly at the beginning of hot pressing. When heating continually and getting plasticity, plastic deformation of the bamboo material takes place, which makes the inside structure of bamboo material compact. During the whole process, the punch is consistently started to supply pressure. The veneer sets gets thinner because of the plastic transformation, and the unit pressure also decreases.

When the bamboo material gets plasticity, it produces a certain amount of compressions, which depend on the bamboo's species, age, site condition, moisture content, pressure, temperature, duration of pressure. As a rule, high pressure, high temperature or long duration of pressure results in an increase of the compression ratio.

The compression ratio can be calculated by the following formula:

$$\Delta = \frac{\sum S - S_p}{\sum S} \times 100\%$$

$\sum S$ : thickness of the mats before hot pressing (mm);  $S_p$ : thickness of the plywood after hot pressing (mm);  $\Delta$ : compression ratio (%).

During the hot pressing process, if only one sheet of mat is loaded in one work compartment of the hot press, there will be relatively small difference in compression ratio; if several sets are loaded in one compartment, the compression ratio will be larger for the sets which is closer to hot pressing board, smaller in between.

During the same period, adhesive on the bamboo curtain will gradually melt because of the heat, and then get solidified, becoming an insoluble and infusible material. Because there is a high temperature area in the central part and a low temperature one around it, when the adhesive at the center is done with the solidification, the adhesive in peripheral area is still underway. That's why the temperature and the duration of hot pressing are determined by its temperature and duration of the peripheral area.

During the pressure-reducing period, steam in the veneer sets spillovers rapidly and the overheated water quickly changes into steam, which leads to the unbalanced pressure inside and outside of the veneer sets. The faster the pressure reduced, the larger the divergence of the pressures. To the extreme, sometimes the mats of the adhesive shells off, which is usually called "bubbling" and it is much often for the thick multi-player boards. So the pressure reducing should be conducted slowly and reduce the pressure while keeping a certain balance between the pressure inside and outside to exclude the moisture in the board gradually. In order to prevent the "bubbling", three stages of pressure reducing should be carried out:

Stage 1: from work pressure to "balancing pressure". The "balancing pressure" is the external pressure to keep the balance with the internal steam pressure, whose value is related to the temperature and unit pressure used in hot pressing. As a rule, when applying phenol resin in ply-bamboo production, the value of "balance pressure" is about 0.3 – 0.4 MPa. During this period, since the external pressure nearly equals the internal steam pressure, the steam and the overheated moisture inside the veneer sets will not spillover in a large amount, maintaining relatively "still". The pressure reducing can be conducted a little fast and usually complete it within 10 – 15 minutes.

Stage 2: from "balancing pressure" to zero. During this period, the reduced external pressure will result in a pressure difference between the outer and inner veneer sets. Besides the large amount of steam inside the veneer sets, the overheated water will also change into steam. At that time, if the pressure is reduced too fast, the great pressure difference will make the steam spillover too rapidly to break the glue layer and induce "bubbling" or "shelling off". So the pressure reducing in this period should be conducted slowly, making sure that the speed of pressure reducing be in line with that of steam excluding.

Stage 3: from zero to splaying of all the hot pressing boards. During this period, the valve should be opened and the boards unloaded as fast as possible to splay

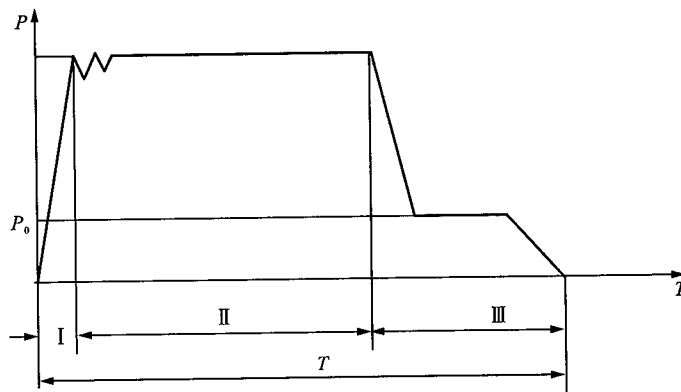

**Figure 4.8** The Curve of Pressure Change in Hot Pressing Process

I. Free heating period (min)  $P$ . Work pressure (MPa) II. Pressure heating maintaining period  
 $P_0$ . Balancing pressure III. Pressure maintaining period (min)  $T$ . A hot pressing period (min)

the boards. At that time, we have to pay much attention to the veneer sets in the lowest work compartment of the hot press, it stands the pressure of hot pressing board itself while the pressure meter may read zero. So we have to slow down when separate the last sheet of board to avoid “bubbling” and the duration of the process depends on the hydraulic pressure system of the hot press.

The pressure change during the whole process of hot pressing and agglutinating refers to Figure 4.8. Its whole process is called a hot pressing period.

However, the unit pressure is large for “thin curtain” type of mat-curtain plybamboo and there is a large amount of moisture inside the veneer sets, the production process “cold input and cold output”. That is, during the cooling period, maintaining certain degree of pressure, increase pressure on the hot pressing board while pour cold water to make it cool down. Unload the board from hot press when the temperature goes down to 50 – 80°C.

Although the hot pressing period for “cold input and cold output” technique is relatively longer, with energy and water consuming, it can ensure a smooth and flat surface, a stable shape of the board. It can also effectively prevent the “bubbling”.

#### 4.2.7 Edging and Trimming

The hot pressed board should be edged and trimmed vertically and horizontally to make it meet the requirement of specified size and error range. The waterproof dope on the cross sections around the products can be coated to improve its appearance and waterproof performance.

#### 4.2.8 Major Quality Standards

The bending strength for “thin curtain” type of mat-curtain plybamboo can reach

100MPa, modulus of elasticity 10,000MPa, density nearly 1.0, with high consumption of the adhesive. The density (only 0.75 – 0.80) and glue-consumption is relatively smaller for “thick curtain” type of mat-curtain ply-bamboo because of the thick curtain, but all the performances are poorer than the “thin curtain” one and can satisfy the requirement of the general construction concrete.

#### 4.2.9 Brief Introduction of Mat-curtain Plybamboo with Impregnated Paper

The mat-curtain plybamboo with impregnated paper are usually made of thin bamboo curtain. Nowadays the thick curtain is also used as lining for it, but the performance is relatively poorer. The mat-curtain plybamboo with impregnated paper

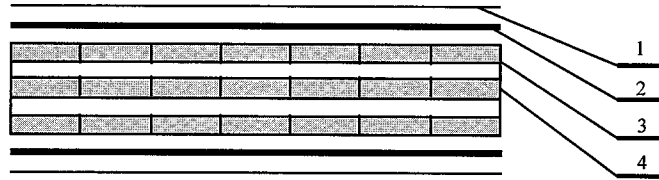

**Figure 4.9** Transect Structure of Mat-curtain Plybamboo Covered with Impregnated Paper

1. Impregnated paper
2. Bamboo mats
3. Crosswise curtain
4. Transverse bamboo curtain

is mainly used as concrete moldboard, which can be used in “clean water” concrete construction. Its production process is similar to ordinary mat-curtain plybamboo. The only difference is to cover the upper and lower surfaces with a piece of impregnated paper in assembling respectively. Before hot pressing a stainless steel plate is placed on the assembled set and another one under the set. In this way a film can be formed on the surfaces of products, which makes the unloading easy. The paper can be impregnated with melamine resin or phenol resin, or melamine-phenol mixed resin. The structure of mat-curtain plybamboo covered with impregnated paper is shown in Figure 4.9.

The physico-mechanical properties of the mat-curtain plybamboo covered with impregnated paper refers to Table 4.2.

**Table 4.2** The Physico-mechanical Properties of the Mat-curtain Plybamboo Covered with Impregnated Paper

Properties	Value
Density ( $\text{g}/\text{cm}^3$ )	0.80
MOR (MPa)	104.5
MOE (MPa)	11,100
Adhesive strength (MPa)	$\geq 2.5$
Attrition resistance of surface	0.05g/100 round

## 4.3 Glued Silver Plybamboo

### 4.3.1 Definition and Usage

Glued sliver plybamboo is formed of bamboo slivers or livers joined together as a whole piece. After drying, impregnating and maturing, the strips and strip pieces are assembled all in lengthwise direction and hot pressed.

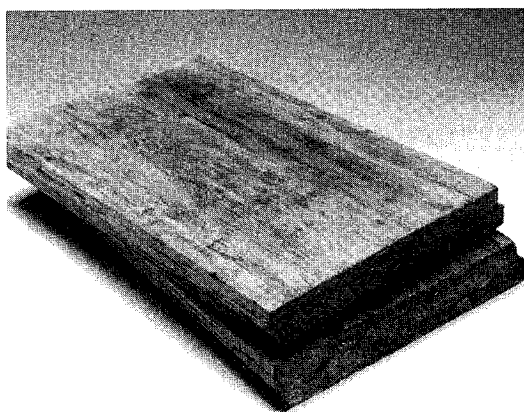
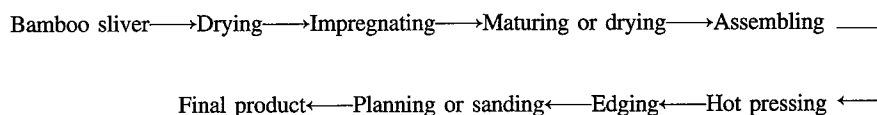

**Figure 4.10** Glued Sliver Plybamboo Used as Railway Boxcar Base Plate

The glued sliver plybamboo features good rigidity and lengthwise strength. It can be used as ideal construction material. It is mainly used as bottom boards of railway wagons and trucks. Its appearance refers to Figure 4.10.

### 4.3.2 Production Process

The production process of the glued sliver plybamboo is simpler than that of weaving plybamboo and the mat-curtain plybamboo. The process is as follows:



### 4.3.3 Raw Material

Plybamboo is made of slivers 0.8 – 1.4 mm in thickness. If the strips are too thick, it can only absorb and impregnate a small amount of adhesive, so the compressibility of the bamboo strip is relatively poor. Meanwhile, the assembling for plybamboo adopts the method of spreading bamboo strips in a large-scale frame by hand. Since the bamboo strips cannot be evenly spread, “overlapping” frequently takes place. Besides, the rigidity and elasticity of the thick bamboo strips is so good that it refuses to undergo plastic deformation and fill up the gaps caused by assembling, even under enormous pressure. The board produced under this circumstance is uneven in density with relatively many gaps and poor MOR and adhering strength. After shaving to certain thickness, there are many deep grooves on the surface of the board, which lead to a poor quality of outward appearance. But if the relatively thin bam-

boo strips are adopted, the above shortcomings can be overcome. So it is suggested to apply thinner strips. The width of the bamboo strips is usually 15 – 22mm, and the length of it should be a little bit more than that of the finished product. Short strips should not be shorter than 30 cm. And the proportion for long and short bamboo strips is 1:0.2 – 0.3. The bamboo strips are usually produced by individual peasants and then purchased by factories.

Making a whole piece of bamboo strips can improve the product's quality and make mechanized and continual production possible. The whole curtains are woven with the strips through threads-warps manually or on weaving machines. The quality requirement for bamboo curtain is similar to that of mat-curtain plybamboo.

#### 4.3.4 Drying and Impregnating

The moisture content of bamboo strips after drying is required to reach 10% – 12%. The strips can be dried naturally or drying in the drying kiln.

The impregnating rate is defined as the proportion between the weight of solid adhesive and that of bamboo strips. The amount of the glue is an important factor to affect the product's quality. Too small amount of glue will lead to poor quality of agglutination, sometime even result in the glue's shelling off. Too large amount of glue will induce a waste on the glue. So the usual impregnating rate is about 6% – 7%. And water-soluble phenol resin can be applied for impregnating.

The amount of glue is measured by weight. Firstly the bamboo curtain's moisture content  $W_0$  and its weight  $G_0$  are measured, then the absolute dry weight of the bamboo strip ( $G_1$ ) is calculated with formula of  $G_1 = G_0(1 - W_0)$ ; then lift the impregnated strips, measure their weight after dripping and artificial drying, and the impregnating rate is:  $\frac{G_2 - G_1}{G_1} \times 100\%$

Strips are bundled with wire ropes before impregnating. The bundles are put into an adhesive pool to impregnate by means of electric hoist. The bamboo strip bundles are hoisted after 1 – 2 minutes and dip it again into the glue pool for 2 minutes, and then hoisted out of the pool to drop the extra adhesive.

#### 4.3.5 Drying after Impregnating

After the impregnating, the impregnated strips are hung for dripping and drying. The moisture content of the dried bamboo strip should be kept at 10% – 14%. The impregnated strips are dried naturally or in kiln dryers. The temperature of the drying kiln have to be at  $\pm 65^\circ\text{C}$  to prevent solidification of the adhesive. Usually the drying lasts 4 – 5 hours. Since there is adhesive on the surface of the bamboo strip, the error is relatively large if resistance hygrometry is adopted. So the weight of the

impregnated strips is measured after drying as  $G_1$  and the absolutely dry weight as  $G_0$ , and the moisture content is:  $\frac{G_1 - G_0}{G_0} \times 100\%$

#### 4.3.6 Assembling

The assembling of the glued sliver plybamboo is conducted on the assembling table manually. The bamboo strips are assembled in the frame after being weighed. Long strips are used for surface layers and short ones for core layers. The jointed strips can be directly spread on the plate. Comparing to the separated bamboo strips, the jointed strips can improve the production efficiency and the uniformity of thickness and density in assembling.

The amount of bamboo strips used in assembling depends on the product's density, thickness and size.

Suppose the specifications of the product are 2,440mm  $\times$  1,220mm  $\times$  30mm. According to the process feature of glued sliver plybamboo, the extra size for edging is about 100mm and the extra size for thickness process is 2mm. In this way, the specifications are 2,540mm  $\times$  1,320mm  $\times$  32mm. For the product with required volume weight 1.1g/cm<sup>2</sup> and impregnating rate 7%, the amount of bamboo strip is:

$$G_1 = L \times B \times D \times R = 254 \times 132 \times 3.2 \times 1.1 = 118,018.56 \text{ (g)} = 118.02 \text{ (kg)}$$

$G_1$ : is the weight of finished product;  $L$ : is length of the board;  $B$ : is the width of the board;  $D$ : is the thickness of the board;  $R$ : is the volume weight of the board.

The absolute dry weight of bamboo strip used for making a bamboo strip board is:

$$G_2 = \frac{G_1}{1 + W_2 + P} = \frac{118.02}{1 + 0.1 + 0.07} = 100.8 \text{ kg}$$

$G_2$ : is the weight of absolutely dry bamboo strip needed;  $W_2$ : is the moisture content of finished product, taking 10%;  $P$ : is the impregnating rate.

The amount of solid adhesive required for every bamboo strip board:

$$G_3 = P * G_2 = 0.07 \times 100.87 = 7.06 \text{ (kg)}$$

$G_3$ : is the amount of adhesive in need.

If the moisture content  $W_3$  of the bamboo strip after impregnating and drying is 14%, the weight ( $G_4$ ) of impregnated and dried bamboo strip for making a bamboo strip board is:

$$G_4 = (1 + W_3) (G_2 + G_3) = (1 + 0.14) \times (100.87 + 7.06) = 123.04 \text{ (kg) or}$$

$$G_4 = (1 + W_3) (1 + P) G_2 = (1 + 0.14) \times (1 + 0.07) \times 100.87 = 123.04 \text{ (kg)}$$

### 4.3.7 Hot Pressing

The hot pressing conditions for laminated ply-bamboo: temperature is 140 – 150°C; unit press is 4.5 – 6.0 MPa; pressing time is calculated by 1.3min per mm of the finished product.

The hot pressing of the laminated plybamboo adopts “cold input and cold output” production process, which is similar to that of “thin curtain” type of mat-curtain plybamboo, increasing the pressure gradually or by stages.

### 4.3.8 Post-processing

After hot pressing, the semi-finished product of the laminated plybamboo should be edged and trimmed, and undergo thickness process by being shaved or sanded by planer or sanding. After that, it is sawed and milled according to the size requirement of bottom board of railway wagon and automobile carriage.

### 4.3.9 Physico-mechanical Properties

The density of the glued sliver plybamboo is bigger than 1.0, the MOR of 30mm thick glued sliver plybamboo can reach 100MPa or above, and the MOE(modulus of elasticity) can reach 8,000MPa or above. Since all the bamboo strips are made in a single direction, the lengthwise strength in one direction is great but the cross-wise strength is relatively poor.

## 4.4 Bamboo Particleboard and Bamboo Particle Composite Board

### 4.4.1 Bamboo Particleboard

#### 4.4.1.1 Definition and usage

Bamboo particleboard is made up of bamboo shavings as elementary units, which undergoes the procedures of drying, adding a certain amount of adhesive and water-proof agent, spreading, shaping, assembling and hot pressing under certain pressure and temperature.

Shavings are made of small-sized bamboo culm and bamboo wastes. The negative effects of green and yellow matter on adhe-

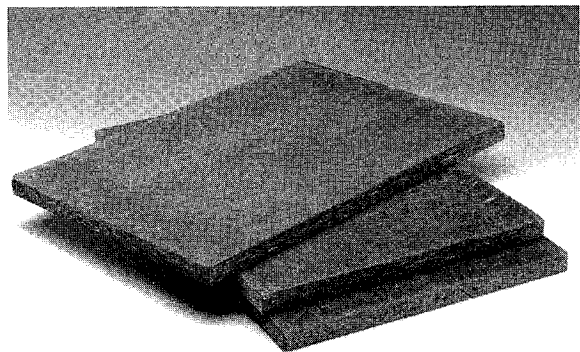

**Figure 4.11** Appearance of Bamboo Particleboard



sion are weakened after shaving so that the agglutination is improved. With extensive raw material for making bamboo particleboard, it is an effective way to enhance the comprehensive utilization of bamboo.

Bamboo particleboard always adopts water-soluble phenol resin as its glue. It is used as construction material because it has not only higher water tolerance and fire-proofing, but also higher modulus of rupture and modulus of elasticity, lower moisture expansion in thickness (comparing to wood particleboard). Bamboo particleboard is mainly used as common concrete moldboard. The appearance of bamboo particleboard refers to Figure 4. 11.

#### 4.4.1.2 Production process

Bamboo particleboard usually is a three-layer high-density board, produced through pressing, which is a similar production process to that of wood particleboard. Specifically, the process using the hot compressor with hot oil as heating medium is demonstrated as follows:

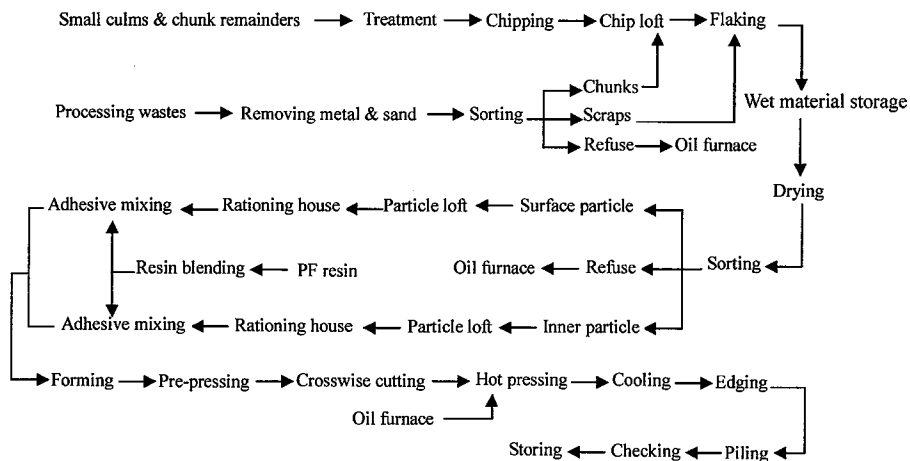

#### 4.4.1.3 Raw material and its treatment

Raw materials include raw bamboo and processing wasters. Raw bamboo refers to bamboos of various diameters. Processing wastes include two categories: chunks such as bamboo root ball, twigs and strips and scraps such as bamboo chips, threads and broken bits. Chunks are to be made into special shavings, while scraps are sorted and regarded as factory shavings. The proportion of factory bamboo shavings should not take up more than 40% of the total; otherwise, the strength of the particleboard will be reduced.

The optimum water content of the materials ranges from 40% to 60%. Low content leads to the increase of broken bits, which may affect the quality of prod-

ucts. High content prolongs the drying time and energy consumption. If the moisture rate is lower than 40% , it is necessary to soak the material in warm water of 50°C in winter and in normal tap water in other seasons. The impregnating time depends on the water content, 2 hours normally. If the water content of the bamboo material is higher than 60% , the storage time period should be prolonged until the water content is equal to or lower than 60% .

It needs enough raw materials to be stored to insure a continuous production for 15 to 30 days. They should be stored in simple constructions with roofs; and the storage should follow the principle that the early-stored materials should be used first so as to guarantee the freshness of the materials and prevent mildewing.

#### **4.4.1.4 Prepreation of shavings**

The lengthwise pulling strength of bamboo material is great while the crosswise is weak. Therefore, the shavings produced are often in needle shapes with their width larger than the thickness. After the process of stripping, the raw bamboo and chunks are made into bamboo pieces 30 mm in length. These pieces are then made into special shavings 0.3 – 0.8 mm in thickness and 1.2 – 2.0 mm in width through the shaving machine. It has been proven that cutter cylinder chipper and ring-type shaving machine meet the requirements for shaving production. The bamboo shavings produced by these machines are of fine shapes, with a small proportion of broken bits.

After the metals and sands are removed, the fine scraps are sorted and stored into wet material storehouse together with special shavings at a prearranged proportion so as to insure an even mixing of these two kinds of shavings. The amount of scraps should not exceed 10% of the total weight.

#### **4.4.1.5 Drying and sorting**

Bamboo shavings are usually dried by rotor drier. The water content of the dried bamboo shavings should be maintained at 2% – 6% .

The dried bamboo shavings are sorted into three categories; large chunks, qualified shavings and wastes. The large chunks should be crushed again before sent to the production line. Proper shavings are conveyed pneumatically to shaving lofts for surface and core layers respectively. And the wastes will be forwarded to boilers or oil furnace as fuels.

#### **4.4.1.6 Adhesive mixing**

Water-soluble phenol resin with higher primary viscosity is often used for the production of bamboo particleboards. If continuous roller pre-compressor and non-pad hot pressing process are adopted, the initial glutinosity of the adhesive is particularly

---

important.

The quality indexes of the adhesive used for processing bamboo particleboard are listed as follows:

Solid content: 47% ± 2%	Viscosity (20°C): 0.26 – 0.3 Pa · s
pH value: 10 – 12	Free formaldehyde: ≤ 0.6%
Storage period: 2 months	

Recipe of waterproof agent (Paraffin emulsion) by weight:

Paraffin: 100	Synthesized fatty acid: 5 – 2 (acid value: ≥ 200)
Water: 150 – 200	Ammonia liquid: 4.5 – 5.5

Quality indicators of paraffin emulsion:

pH: 7.0 – 8.5	Volume Weight: 0.9 – 0.94 g/cm <sup>3</sup>
Paraffin concentration: 20% – 40%	

Granularity: more than 90% of granules are ≤ 1 μm

Storage period: no delamination or agglomeration for 3 days.

The phenol resin is mixed with paraffin emulsion according to proper mixing proportion. The applied paraffin amount (the percentage of solid paraffin compared to the absolute weight of dried shavings) relies on the specific requirements of various products, with a normal range from 0.3% to 1.0%.

The average applied adhesive amount of bamboo particleboard (the percentage of solid adhesive compared to the absolute weight of dried shavings) is about 9% – 12%. As the size of core – layer shavings is bigger, the applied adhesive amount should be reduced; while since the size of the shavings of surface layer is smaller, the applied adhesive amount should be at the top level. The adhesive amount is controlled by adhesive transfer pump. The weight of adhesive supplied to the adhesive mixer is calculated on the basis of the weight of shavings in the mixer and the pre-fixed applied adhesive amount.

The water content of the bamboo shavings mixed with adhesive should be kept in the range from 9% to 16%. The shavings in core-layer should be a little bit lower than that of the surface layer. The storage period of adhesive-mixed bamboo shavings should not exceed 2 days.

#### 4.4.1.7 Forming and pre-pressing

Shavings are spread by means of airflow or on forming machine, which guarantee the evenness of density and smoothness of surface. Thus, the defect of twisting and deformation resulted from uneven density by manual forming can be avoided. The feeding and measuring system should be adjusted according to the density, thickness and structure of final products.

If the shavings are hot-pressed without metal plates, the pre-pressing can be completed by a continuous rolling machine, connected with forming machine. If

shavings are hot-pressed with metal plates, the pre-pressing can be finished by a pressing machine of single tier (or to be hot-pressed without the pre-pressing). The pre-pressed sets are more grain-closed, of certain strength, which may prevent the crack and rupture in transportation. During pre-pressing the air is extruded from shaving sets and the thickness of sets is reduced, which decreases the space between hot-plantens. The indexes of pre-pressing are:

Linear pressure of rolling machine: 1,000 – 2,000 N/cm

Unit pressure of pressing machine of single tier: 1.0 – 1.6 MPa

Compression rate of the set: 30% – 50%

Reversion rate of the board flange: 15% – 25%

$$\text{Compression rate} = \frac{h_1 - h_2}{h_1} \times 100\%$$

$$\text{Reversion rate} = \frac{h_2 - h_3}{h_1} \times 100\%$$

$h_1$ : thickness of spread sets (mm);  $h_2$ : thickness of sets after reversion (mm);  
 $h_3$ : minimum thickness of sets during pre-pressing (mm).

Hot pressing is one of the crucial procedures during the production of bamboo particleboard, with a direct impact on the production line efficiency and product quality. Hot-press can be of great size and single- or multiple-tier. Nowadays multiple-tier hot compressor is more often used.

As the density of bamboo is higher than that of wooden materials, it is imperative that higher pressure should be imposed during the hot pressing process to ensure a close contact among bamboo shavings. In the process of hot pressing, the three factors (pressure, temperature and time) are inter-dependent. If the temperature is to be raised, the temperature gradient should be increased so as to speed up the thermal transmission and shorten the heating time. However, too high temperature will solidify the adhesive on the surface shavings before the closing of platens and pressing operation. As a result, the surface shavings will get loose and fall off. The following is up-to-date hot pressing conditions for the production of bamboo particleboard:

Pressing temperature:  $T = 160 - 180 \text{ }^\circ\text{C}$

Pressing time:  $t = 0.4 - 0.7 \text{ min/mm}$  in thickness of final product. In general it is fixed at  $0.5 - 0.55 \text{ min/mm}$

Unit pressure:  $P = 4.0 - 4.5 \text{ MPa}$

The final thickness of bamboo particleboard is regulated by the steel gauge during the hot pressing process. Attention should be paid that scraps on the gauge should be removed during the production process.

#### 4.4.1.8 Physical and mechanical property

As both of bamboo's density and strength are higher than those of wood, the density and mechanical properties of bamboo particle - board are better than those of ordinary wood particle - board. The physico-mechanical property of bamboo particle-board is demonstrated by Table 4.3.

**Table 4.3 Physical and Mechanical Properties of Bamboo Particleboard**

Item	Unit	Indexes
Density	g/cm <sup>3</sup>	0.85 - 0.95
MOR	MPa	27 - 40
MOE	MPa	3,000 - 4,000
Plane pulling strength	MPa	0.7 - 0.8
Expansion ratio in thickness	%	≤8

#### 4.4.2 Bamboo Chip Composite Board

Though bamboo particleboard boasts of high utility efficiency of raw materials and high mechanization level during the production process, compared to other bamboo-based artificial boards, it also bears shortcomings such as low mechanical strength, heavy volume weight, weak stability in size and high possibility to get moldy. For the purpose of overcoming these defects and bringing the respective advantages of various board materials into full play, bamboo chip composite board was developed.

##### 4.4.2.1 Definition, classification and usage

Bamboo chip composite board is formed with bamboo fiber as the major component. Using bamboo shavings as the core-layer material, bamboo strips or mat as the surface material, with adhesive coated on bamboo shavings and strips or bamboo mats soaked in adhesive, through hot pressing, it turns up to be a sandwich structure composite board. Based on its cover configuration, bamboo chip composite board can be divided into mat-covered board and strip-covered board. Mat-covered board is used to make concrete forms; strip-covered board is used as floorboard and bottom of trucks and buses. The transect structure of bamboo chip composite board is shown in Figure 4.12 and Figure 4.13: 1. Bamboo mat 2. Particle core.

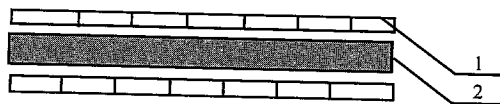

**Figure 4.12** Sketch of the Transect Structure of Mat-covered Board

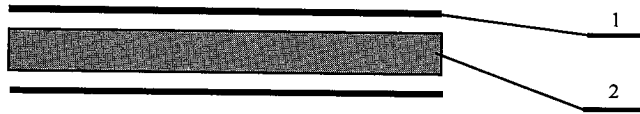
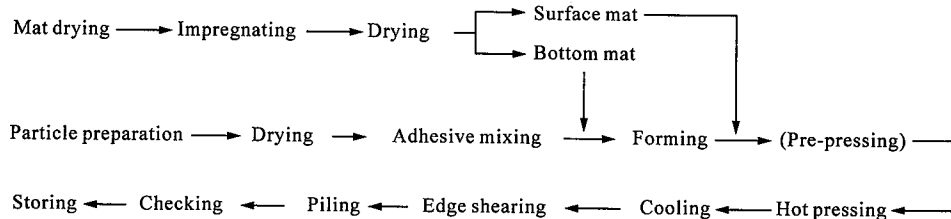

Figure 4.13 Sketch of the Transect Structure of Bamboo Strip-covered Board

#### 4.4.2.2 Production process

##### a. Production process of mat-covered board

The first step is to lay an impregnated and dried mat for forming shavings. Spread particle on the mat and cover the shavings with another impregnated and dried mat for hot pressing and further processing. The specific process is as follows:



##### b. Production process of strip-covered board

The production of strip-covered board often adopts the twice-molding technique. The production process of strip-covered boards depends on their uses. The following is the production process of strip-covered board used as floorboard:

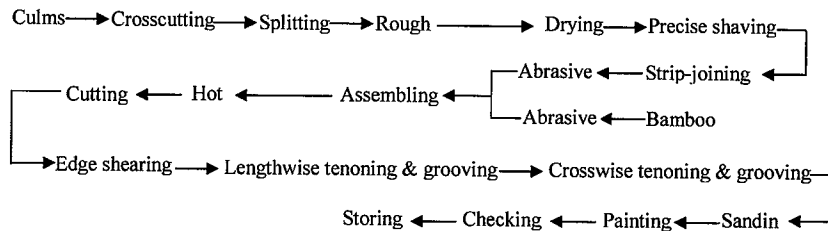

##### c. Key points for the production of mat-covered board

As the surface layers are made of bamboo mats, the shavings can be spread not so precisely. Normally, machines with two forming heads are used to produce assembled sets with a gradually changing structure. Since the assembled sets that are hot-pressed with protecting plates should be covered with bamboo mats at both sides. Before moving into forming machine the base plate must be covered with one or two impregnated and dried mats. A certain amount of adhesive-mixing bamboo shavings should be paved inside the machine, and then the base plate with mats is put into the forming machine, spread with bamboo shavings and covered with other one or two

mats. It is also suggested to lay a bamboo curtain when the shavings are spread to half of the pre-determined thickness. This improves the shock resistance of products. The shock resistance is one of the most important parameters for judging the quality of concrete form.

*d. Key points for the production of strip-covered board*

For the production of strip-covered board, the strips can be joined together with adhesive to form a whole layer, then to be assembled in the way as that of mat-covered board. It is also possible to produce bamboo particleboard first, sand and coat it with adhesive, then assemble it with coated lengthwise strip layers. The production process of strip layers is the same as that of bamboo strip of single layer. If the product is to be used as floorboard, attention should be paid to the color of strips. They can be bleached or carbonized in case of need.

*e. Physical and mechanical properties*

The major physical and mechanical indexes for bamboo particleboard and bamboo Particle Composite board are listed in the following Table 4.4.

**Table 4.4 Physical and Mechanical Properties of Bamboo Particleboard and Bamboo Particle Composite Board**

Properties	Density ( $g/cm^3$ )	Water expansion rate (%)	MOR (MPa)	MOE (MPa)	Plane tensile strength (MPa)
Mat-covered board	0.85-0.95	$\leq 8$	40-65	—	—
Strip-covered board	0.96	2-3	70-90	7000-8000	2.0-3.0

Remarks:

1. The MOR and MOE of strip-covered board are measured in lengthwise direction;
2. The thickness of strip-covered board is 18mm and its bamboo strips are 4.5 mm thick.

This table demonstrates better mechanical properties of bamboo particleboards as a result of strengthened surface layers. The lengthwise strength of strip-covered board is especially improved because of the strips of proper thickness arranged in one and the same direction. This kind of board is suitable for making floorboard and bottom of vehicles. Mat-covered board is fit for making concrete forms due to its uniform strength.

### 4.4.3 Bamboo Particleboard Coated with Impregnated Paper

#### 4.4.3.1 Classifications and uses

Strip-covered board coated with impregnated paper is mainly used for making concrete forms. Concrete components produced by such concrete forms have even surface, and there is no need to mend them with concrete mortar. One or two layers of varnish paper are processed to cover the surface of bamboo particleboard or strip-covered board to improve the surface quality. These coated boards can be divided into three types in accordance with their structures: concrete template of bamboo particleboard coated with impregnated paper; concrete template of bamboo mat particleboard coated with impregnated paper; concrete template of bamboo-curtain particleboard coated with impregnated paper. The structures of these boards are shown in Figure 4.14 – 4.16.

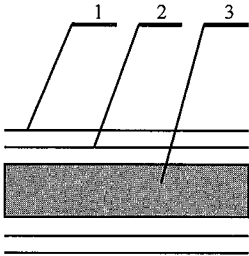

**Figure 4.14** Structure of Bamboo Particleboard Coated with Impregnated Paper

1. Surface paper impregnated with melamine resin 2. Sub-surface paper impregnated with PF 3. Bamboo particleboard

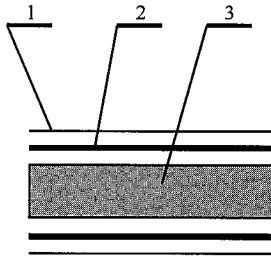

**Figure 4.15** Structure of Bamboo Mat Particleboard Coated with Impregnated Paper

1. Surface paper impregnated with melamine resin 2. Impregnated mats 3. Bamboo particleboard

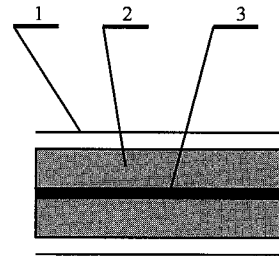

**Figure 4.16** Structure of Bamboo Curtain Particleboard Coated with Impregnated Paper

1. Surface paper impregnated with melamine resin 2. Bamboo particleboard 3. Impregnated bamboo curtain

#### 4.4.3.2 Main points of production

Concrete template of bamboo particleboard coated with impregnated paper and concrete template of bamboo curtain particleboard with impregnated paper are manufactured by means of two-step molding. It means that they are produced to be base material, and are processed on shaving and abrasive machines, then to be coated with varnish covering. In this way the thickness error can be controlled. Concrete template of bamboo mat particleboard with impregnated paper is manufactured by one-step molding, because its surface cannot be processed on abrasive machine.



*a. Production technology of concrete template of bamboo particleboard coated with impregnated paper*

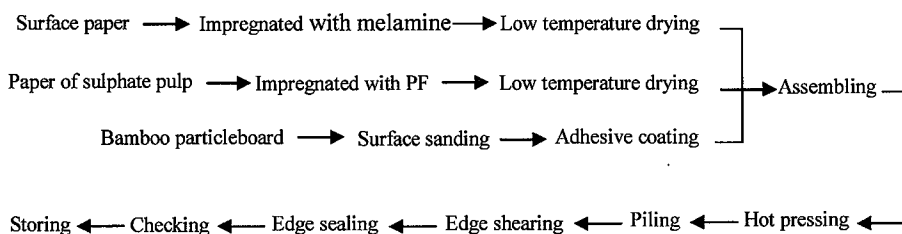

*b. Production process of concrete template of bamboo mat particleboard coated with impregnated paper*

The production process is the same as that of mat-covered board, the only difference is that the mats should be laid together with impregnated paper before and after forming shavings.

*c. Production process of concrete template of bamboo curtain particleboard coated with impregnated paper*

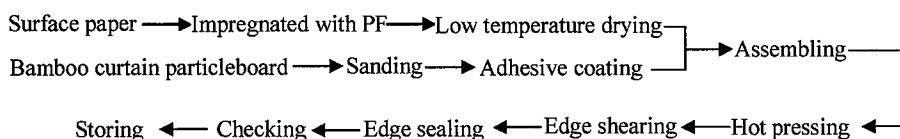

**4.4.3.3 Raw material and key production procedures**

*a. Impregnated paper*

Titanium white paper is selected as surface paper, and sulphate pulp paper as sub-surface paper, about 100g/m<sup>2</sup>. If the supply of titanium white paper is limit, it is acceptable to use sulphate pulp paper as surface paper for reducing production cost. The resin content of impregnating should be 80% - 120%, the content of volatile matter after drying should be 10% - 15%. To increase the alkali, acid and attrition resistance of the surface, the surface paper should be dipped with melamine resin.

*b. Base plate of bamboo chipboard and curtain chipboard*

The base plate must be of desired mechanical properties and fine appearance. It is preferable to smear phenol resin on the base plate after sanding if it is to be coated with one layer of varnish paper.

*c. Hot pressing*

Concrete template of bamboo mat chipboard coated with impregnated paper is manufactured by one-step molding. The pressure temperature is 135 – 145°C, and the pressure is 4.0 – 4.5 MPa. To make the surface smooth and bright, the hot pressing should be implemented in the way of “cold loading and cold unloading”. Concrete template of bamboo chipboard and bamboo curtain chipboard coated with impregnated paper are manufactured by means of two – step molding. The pressure is 1.5 – 1.8 MPa and the pressing time is 10 – 12 min.

*d. Edge sealing*

After shearing, the four edges are to be sealed with phenol resin or other kind of waterproof paint which may improve its water resistance property and enhance external appearance.

## 4.5 Bamboo-wood Sandwich Board

### 4.5.1 General Introduction

With the development of bamboo research and utilization, bamboo-based panel industry has just begun to take shape. But some problems must be resolved in this process. 1. The physico-mechanical properties of man-made bamboo boards constituted with strips and skin, such as ply-bamboo, ply-bamboo of weaves and bamboo strips are satisfactory, but the utilization ratio of culms and productivity are rather low. The scale of production has been limited. 2. The utilization ratio of material in bamboo chipboard, constituted by bamboo fibers, is high, but the mechanical properties of products are low, with unstable dimensions mould-prone quality, which affect their uses and promotion. 3. Bamboo processing is more difficult than wood processing due to the unique structure and dimensions of bamboo material, which restrict the diversification of products. To counter these problems, products of different elementary component units and different materials are being worked out. These composite products can be designed in accordance with their uses and force balance conditions, to bring the strong points of bamboo and wood into play simultaneously. The high-intensity of bamboo culms and easy-to-be-processed and low price of wood would be combined into bamboo-wood composite boards. Thus the research and development of it have received more attention.

#### 4.5.1.1 Definition and classifications

Bamboo-wood composite boards are man-made boards formed of two or more components of different properties (types, forms, etc), pressed together with adhesives, processed with special technologies with bamboo and wood as major raw ma-

terials.

There are a great variety of such products, which cannot be classified according to one standard. The existing products on market are as follows; Bamboo-wood sandwich composites coated with impregnated paper for making concrete forms; Bamboo-wood sandwich composites coated with impregnated paper for making container bottom; Bamboo sliver-wood sandwich composites; Bamboo-fir sandwich composites for making flooring.

#### **4.5.1.2 Characteristics**

Properties of bamboo-wood composite boards depend on the properties of their component units and the location of units in the product structure, as well as on the production technology. Therefore the composite boards have the following features: Make full use of the advantages of components of different materials, creating varied properties for a product; Design and manufacture the product complying with the specific requirements; Utilize various raw materials from abundant resources effectively.

In a word, the successful combination of different materials leads to the improvement of product quality, rationalizes production technology, raises the productivity and utilization ratio, and decreases the production cost.

### **4.5.2 Concrete Template of Bamboo Plywood Coated with Impregnated Paper**

#### **4.5.2.1 Preface**

With the rapid development of modern construction industry, more and more concrete components of high quality are to be made on the construction sites. Consequently, the concrete templates have to meet higher quality requirements: 1. Higher modulus of elasticity and modulus of rupture. Since the pouring of concrete is accompanied by significant side pressure (about  $8\text{t/m}^2$  regularly), if concrete templates are not rigid and strong enough to bear such a pressure, the weight of templates will increase which would affect the work efficiency. 2. Even and smooth surface with proper rigidity, which can be used repeatedly. 3. Higher water-, heat-, alkali- and aging-resistance properties. Because alkaline concrete releases heat when it solidifies, and outdoor conditions are severe, concrete templates must meet the requirements for plywood of first class. 4. Greater dimensions to raise work efficiency. Among various kinds of templates, concrete template of bamboo plywood coated with impregnated paper is most suitable for meeting the above-mentioned requirements.

#### 4.5.2.2 Definition and uses

Concrete template of bamboo plywood coated with impregnated paper is made of bamboo culms, together with the adhesive of phenol resin to form base plate. The varnish paper dipped with phenol resin or melamine is used to coat the board. Such board is applied to make concrete forms of high quality and high strength for producing “clean water” concrete components. In comparison with ordinary plywood and ply-bamboo, this concrete template of bamboo plywood coated with impregnated paper is advantageous in lower moisture expansion rate, smaller ejecting absorption and smoother surface, which can be widely used on major construction bridges, express-way overpasses and elevated ways, where concrete components of great dimensions are made on the spot without further processing. It is the so-called “clean water” concrete project. The section structure of bamboo plywood coated with film covering is shown in Figure 4.17.

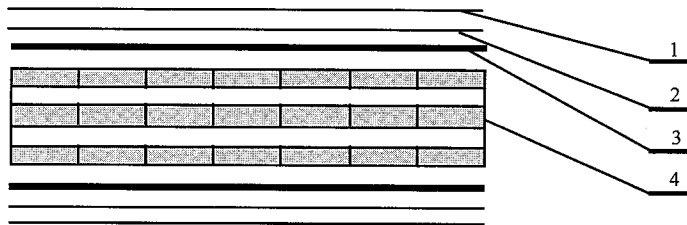
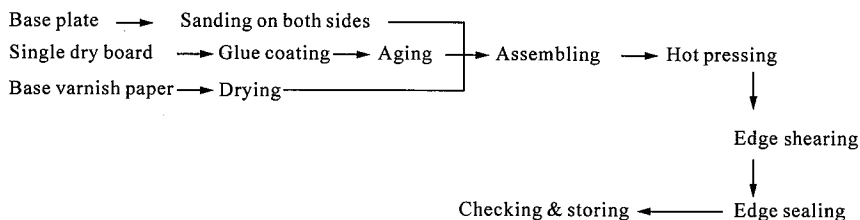

**Figure 4.17** Bamboo-wood Sandwich Composite Coated with Impregnated Paper

1. Surface paper 2. sub-surface paper 3. Crosswise wood veneer 4. Bamboo curtain ply-bamboo

#### 4.5.2.3 Production technology

The flow chart of production technology is as follows:



#### 4.5.2.4 Material and process

##### a. Base-plate

Two kinds of bamboo-based panels can be used as base-plate. One is ply-bamboo manufactured with “softening - flattening” technology. The other is ply-bamboo of curtains, which are woven on weaving machines.

The coating of varnish paper under the high temperature and pressure would cause the reflection of base plate’s defects on the surface, in various degrees. If the

**Table 4.5 Physical-mechanical Properties of Concrete Template of Bamboo Ply-wood Coated with Film Covering**

Item	Units	Amount
Density	G/cm <sup>3</sup>	0.78
Static bending strength	MPa	108
Longwise modulus of elasticity	MPa	10300
Crosswise modulus of elasticity	MPa	7000
Bonding strength	MPa	≥ 2.5
Abrasive resistance of surface		2000 times, 0.05g/100 revolving times
Water-absorbing expansion ratio	%	2.3 (soaked for 24 hours)

### 4.5.3 Bamboo-wood Composite Ply-wood for Baseboard of Containers

#### 4.5.3.1 Definition and uses

Bamboo-wood composite ply-wood for baseboard of containers is a special kind of thick ply-bamboo-wood. Its patent has been obtained in China to protect this invention as an intellectual property. Phenol is used as adhesive, and the core layer of this product is veneer peeled off from masson pine and larch; the surface layers are varnish paper, multi-layer thin strip curtains and mat, or strips of same width and same thickness. These components are assembled scientifically, hot pressed, glued and processed. Due to its high quality, bamboo-wood composite ply-wood for baseboard of containers has been approved by French Ship Service. It has been widely used in container manufacturing industry. The section structure of two kinds of such product is shown in Figure 4.18.

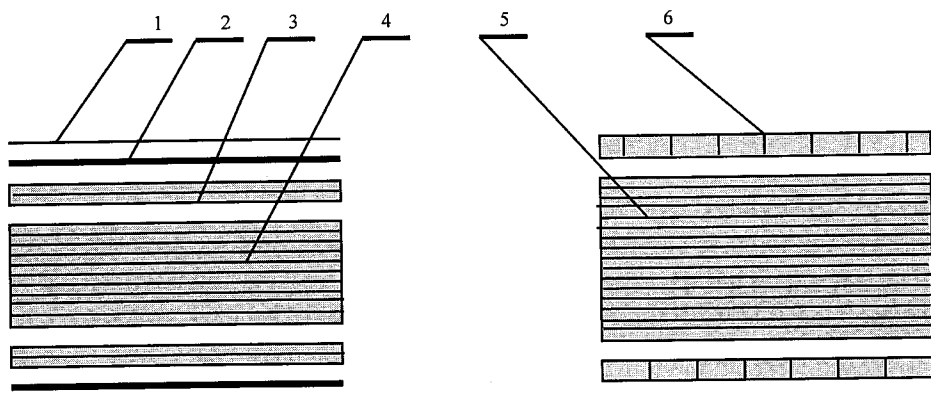

**Figure 4.18** Section Structure of Bamboo-wood Composite Ply-wood for Baseboard

1. Varnish paper
2. Bamboo mat
3. Thin bamboo curtain (2-3 layers)
4. Pine veneer
5. Bamboo strips of same width and thickness

**4.5.3.2 Production technology**

The structure of bamboo-wood container baseboard is designed complying with the principles of structural mechanics of complex materials. By making full use of features of both bamboo and wood, the product is designed to meet the demand for container baseboard. Its core layer is made of pine veneers 1.6 – 2.0 mm in thickness, compressed together in the way of plywood production. The surface layer of type a (bamboo strip) is made in the way of producing first section of plybamboo of curtain-mat, while that of type b (bamboo strips) is in the way of first section of bamboo flooring production. At present the structure of type a is applied in production, the manufacturing process is as follows.

**4.5.3.3 Major production process and raw materials**

*a. Bamboo mat and bamboo curtain*

Because of the high requirements on the thickness warp of container plywood floorings, strict limits should be set to the thickness warp of bamboo strips of the bamboo mats and bamboo curtains purchased. Generally, the thickness warp of bamboo strips should be limited to  $\pm 0.2$  mm. The bamboo strips used for bamboo curtains should be straight. Otherwise, the bending of bamboo strips certainly result in unparallel and partial overlapping, however, we should try our best to avoid the overlapping of bamboo strips. Bamboo mats must be woven as tight as possible and no slots are allowed. Therefore, bamboo strips should be pre-dried before they are woven (usually they are basked in the sun). Or else, after drying, the slots of the bamboo mats which are woven with wet strips will be enlarged as a result of contraction. Besides, bamboo mats and bamboo curtains should avoid mildewing and the bamboos used for raw materials should be more than four years old.

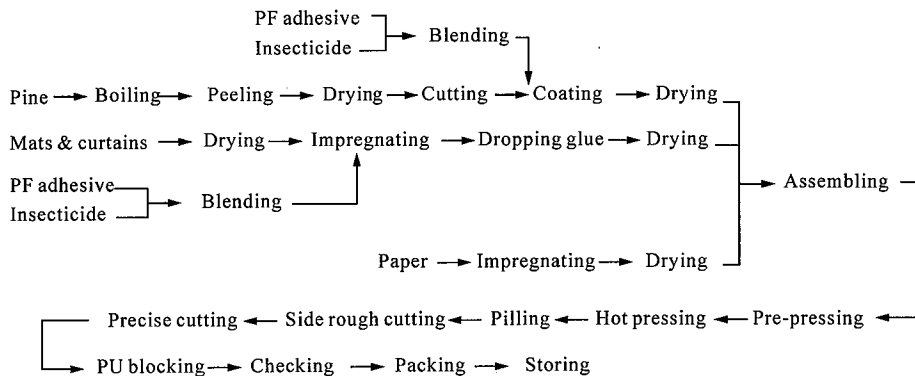

*b. Drying*

Bamboo veneers, bamboo mats and bamboo curtains should be dried before and after coating or soaking in order to guarantee the quality of bamboo-wood composite

container plywood baseboards.

**Veneer drying.** the moisture content of veneers after drying is relevant to the processing of veneers after glue coating. If veneers are air dried after glue coating, the moisture content should be within the range from 4% to 6% ; if they are dried at a low temperature after glue coating, the moisture content should be around 8% . While they are dried at a low temperature, the drying temperature of veneers with coating glue should be less than sixty degrees centigrade.

**Drying of bamboo mats and bamboo curtains.** Since the bamboo mats and bamboo curtains purchased hold quite different moisture content, they tend to be mildewed. Therefore, once purchased, they should be immediately dried by putting them into the kiln or the wire belt dryer. After drying, the final moisture content of bamboo mats should be less than 8% and the final moisture content of bamboo curtains should be less than 10% . Bamboo mats and bamboo curtains after glue soaking will gain a certain amount of glue ( the glue amount of bamboo mats is generally bigger than that of bamboo curtains ), meanwhile the moisture content will increase. As a result, bamboo mats and bamboo curtains should be dried after glue soaking. Structurally, bamboo mats are kept close to the dipper and the moisture among intersections of bamboo strips is not easily to be removed, therefore bamboo mats with lower moisture content are required. Generally, the moisture content of bamboo mats with soaking glue should be within the range from 6% to 8% ; while the moisture content of bamboo curtains should be within the range from 8% to 10% .

*c. Glue mixing*

According to the regulations of the Australian AQIS, there must be a certain amount of insecticide inside container plywood floorings. Because wood veneers, bamboo mats and bamboo curtains are all very thin, mothproof treatment should go through the following procedures: firstly, put the mothproof agent into the adhesive liquid, then mix them evenly, and finally the mixture will leak into the board flange through glue coating and soaking. When hot-pressed, the mothproof agent will leak into wood veneers and bamboo veneers through heat dissipation and then takes effect. Accordingly, while mixing, we should first figure out the accurate proportion of mothproof agent to adhesive liquid according to the requisite rudimental amount of mothproof agent in each cubic meter of the product, the glue consumption in each cubic meter of the product and all kinds of wastage, then mix the glue in accordance with the proportion. Generally, different glue consumptions will lead to different mixing proportions.

*d. Pre-compressing*

Because bamboo veneers with glue coating are dried at a low temperature or air

dried for a certain time and bamboo mats and bamboo curtains with soaking glue are also dried, board flans cannot be glued into shapes when they are cold pressed in the pre-compressing. The purpose of pre-compressing the board flan is to planish and eliminate the interspaces between the veneer and the bamboo curtain, to thin the board flan and put it into the hot press more easily.

*e. Hot-pressing*

Considering the high requirement of the physical and mechanical properties of container plywood floorings, certified products can only be produced by adopting appropriate hot-pressing process. In the production process, if the moisture content of the material can be well-controlled, we can employ the “hot loading and hot unloading” technology to shorten the hot-pressing period and reduce the consumption of the steam and the cooling water. If the moisture content of the material cannot be well-controlled, we should use the “Cold-hot-Cold” or “hot-hot-cold” technology. For example, we can adopt the “hot loading and hot unloading” technology. Because of the comparatively high compression ration of the board flan, the moisture is not easily to be discharged. Therefore, we ought to prolong the exhausting time at the later stage in order to avoid swelling. The commonly-adopted conditions for hot-pressing in production are as follows:

Temperature: 135 – 145°C

Pressure: 3.0 MPa

“hot loading and hot unloading” hot-pressing period: 55 – 60 minutes

“Hot-Hot-Cold” hot-pressing period: 80 minutes

#### 4.5.3.4 Quality standard

Containers are used around the harbors, the lands and the oceans at every corner of the world. The using environment is changeable and harsh. As loading and unloading equipments, container plywood floorings are required to have excellent properties. Consequently, every block of products should pass the strength testing.

*a. Strength testing*

According to the standard requirements of ISO1161, the strength testing of the floorings is composed of the following procedures:

① Use a lorry to carry  $2R-T$  ( $R$  refers to the rated loading weight of the container,  $T$  refers to the empty container’s weight) steel ingot into a container and put them evenly on the floor, then carry out two kinds of lifting tests: namely, testing of lifting from the bottom of the container and testing of lifting from the top of the container. ② Unload the steel ingot, drive a specially equipped rolling car (7,260kg.) into the container and roll the floor back and forth for more than three times, and check the residual deformation of the floor at every testing phase. The



maximal residual deformation should not exceed 3mm.

*b. Physical and mechanical properties*

The widely-adopted container plywood floorings nowadays are produced by Apitong and Keruing tropical hardwood plywood which are imported from Southeast Asian and bamboo-wood composite plywood. The following index of the physical and mechanical properties in Table 4.6 refers to the standard of Apitong plywood floorings.

*c. Appearance quality*

The smear-resisting ability and the easiness to be washed of container plywood floorings is one of the testing standards. After facing treatment with varnish paper, bamboo-wood composite plywood floorings owns the characteristics of strong smear-resisting ability and high easiness to be washed. The factors affecting appearance quality include quality and color of the varnish paper, volatility of the varnish paper, quality of the bamboo mats (including the evenness of the thickness of bamboo strip, the tightness of weaving, the existence of residual bamboo shaves and mildew spots), the hot-pressing process, and the late processing and porting (for instance, sawing burs, surface scratches, hollows, defects at the edge of the veneer, etc.). Quality insurance system should be set up during the production and full-scale quality management should also be carried out.

**Table 4.6 The Index of Physical and Mechanical Properties of Bamboo-wood Composite Plywood Floorings and Apitong Plywood Floorings**

Item		Unit	Standard	Consulting standard of testing
Moisture content		%	≤12.0	GB8846.11-88
Density		g/cm <sup>3</sup>	≤0.85	GB8846.11-88
Bending strength (MOR)		MPa	≥75.0	JISZ 13-63Z
	⊥	MPa	≥30.0	JISZ 13-63Z
Elastic modulus (MOE)		MPa	≥10000	JISZ 13-63Z
	⊥	MPa	≥3000	JISZ 13-63Z
Aging property (six-cycle treatment)	MOR	MPa	≥37.5	ASTMD1037-78
	⊥	MPa	≥15.0	ASTMD1037-78
	MOE	MPa	≥5000	ASTMD1037-78
	⊥	MPa	≥1500	ASTMD1037-78
Bonding strength		MPa	≥0.70	JAS I-plywood

### 4.5.4 Floor of Bamboo-wood Compound Assemblies

#### 4.5.4.1 Definition and usage

Floor of bamboo-wood compound assemblies is a kind of hot-pressed composite material which is made of bamboos (bamboo strips or bamboo curtains) of great strength and hardness as their surface materials, Chinese red pines or larches as their core materials and good climate-resistance resorcinol formaldehyde resin as their adhesive. Several layers (usually three layers) of pinewood boards and bamboo strips or several layers of thin bamboo curtains are ranged lengthways. A layer of transverse wood veneer or transverse, thin wood curtain can be inserted between vertical pinewood boards. With the characteristics of great vertical strength, good climate-resistance and relatively small density, the product is suitable to be used as flooring of railway flat car, panel of shipboard, scaffold board for shipbuilding. The scaffold board for shipbuilding is highly strict with weight, therefore it is hollowly structured.

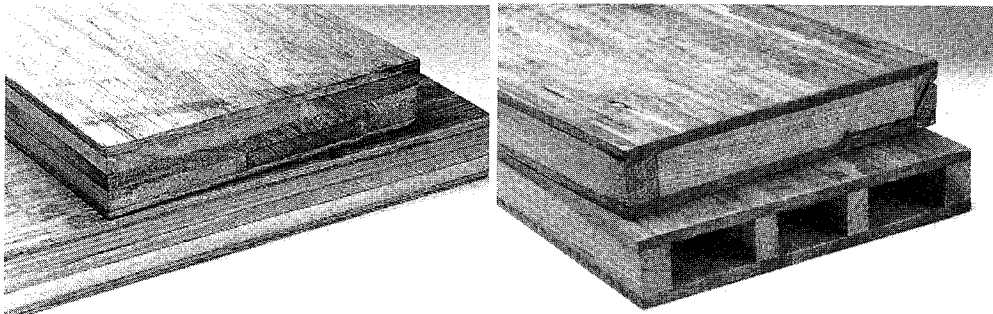

a. Solid floor bamboo-wood compound assemblies      b. Hollow floor of bamboo-wood compound assemblies

**Figure 4.19** Outline Drawing of Floor of Bamboo-wood Compound Assemblies

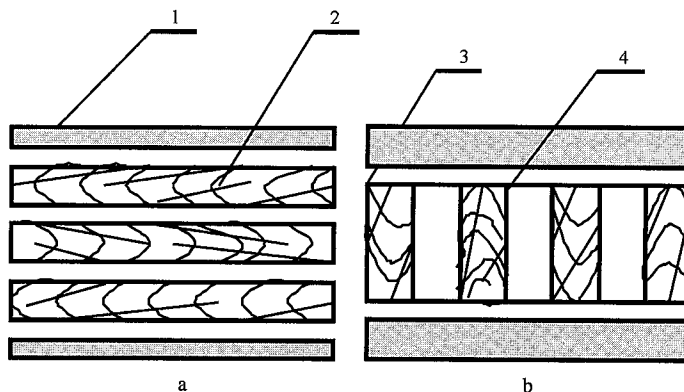

**Figure 4.20** Schematic Diagram of Floor of Bamboo-wood Compound Assemblies

- a. Solid floor of bamboo-wood compound assemblies      b. Hollow floor of bamboo-wood compound assemblies  
 1. High-density board of bamboo curtain (containing a layer of transverse bamboo curtain)    2. Thin wood block  
 3. High-density board of bamboo curtain    4. Scantling

Type a is a kind of solid bamboo curtain composite with its thickness of 45mm. It can be used as flooring of railway flat car substituting for red pine floor which is 70mm thick. Type b is a kind of hollow bamboo curtain composite which is lighter than Type a, much stronger and fairly rigid. It is mainly used as panels of shipboard with its length respectively of 2m, 3m and 4m and its thickness respectively of 50mm and 60mm. See Figure 4.19, 4.20.

#### 4.5.4.2 Production process

##### a. Technological Production Process of Floor of Bamboo-Wood Compound Assemblies with Bamboo Curtain Plywood

Firstly, we hot-press the six to nine layers of thin bamboo curtains with soaking glue into veneers. After they are singly planed or pared, we abrade and sand them. Then we join them into a whole piece of pine board which is then hot pressed into a kind of composite material. The technological production process is as follows:

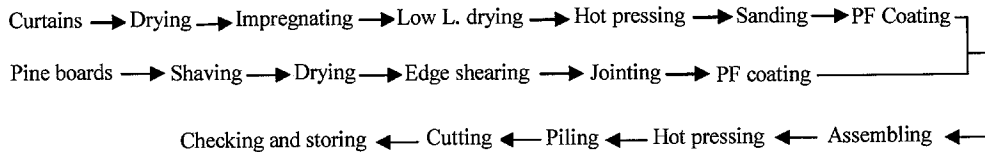

##### b. Technological Production Process of Hollow Bamboo Curtain Composite Panel

Hollow panel is also produced through two time's shaping process as follows:

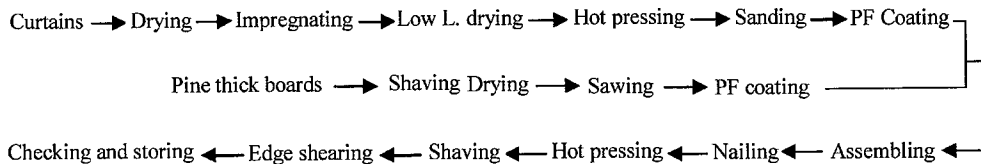

#### Major production procedures and material

##### a. Raw material

To produce bamboo strips and bamboo curtains, we should choose more than four-year-old bamboo culms as raw materials. Bamboo curtains must be woven with fitting tightness and the thickness of bamboo strips should be as even as possible within the range of 1.0mm to 1.2mm. Besides, mildewing is not allowed. The thin pine wood panels (15mm in thickness) which are used for producing bamboo strip or bamboo curtain composite structures is made of intermediate-cutting wood and small-diameter timber. The deformation resulting from slight drying will not affect

the usage. To produce thick panels (45mm in thickness) which are used for hollow structure, we should select those high-quality Chinese red pines or larches whose node is small in diameter and few in number, for it is a big factor affecting the rigidity of hollow structure.

*b. Drying*

Generally, thin veneers are dried after planing and dissecting, while thick veneers used in hollow structure should be planed and dissecting only after being dried in order to ensure the wood's linearity and even thickness. The final moisture content of the veneers after being dried should be equal to or less than 12% ; The final moisture content of the bamboo curtains which are dried before glue soaking should be equal to or less than 12% , while the final moisture content of the bamboo curtains which are dried after glue soaking should be within 12% to 14% ; the moisture content of wood veneer is equal to or less than 8% .

*c. Glue coating and glue soaking*

Both the wood veneers after glue coating and the bamboo curtains after glue soaking should get a certain amount of glue. Resorcinol formaldehyde resin is often used as adhesive. To the adhesive which is used for glue coating we can add a certain proportionate amount of flour and wood powder. After mixing completely, the mixture can be used for glue coating. The adhesive for glue soaking can be diluted with water into appropriate solid content without flour and wood powder. Bamboo curtain can only be blank-made until it is not sticky to the hand after air drying or low temperature drying.

*d. Bamboo curtain hot-pressing*

Panels used for making bamboo curtain plywood are produced by hot-pressing five to seven layers of thin bamboo curtain, while panels used for making hollow bamboo curtain plywood are produced by hot-pressing thirteen to fifteen layers of bamboo curtain. The parameter of hot-pressing is as follows: unit pressure: 4.0 – 5.0 MPa; temperature: 130 – 140°C ; the time of hot-pressing is determined by the assembling thickness and the hot-pressing process.

*e. Side sanding and side planing of cementing surface*

After glue soaking, the layer of setting glue template which is on the surface of the bamboo curtain board after hot-pressing and gluing can affect the second times' shaping process. Thus, we should use the single-side press wood planer with big planing width to plane the entire glue template on the major cementing surface. If financially permitted, it is advisable to use a wide-belt sander to plane the glue tem-

plate.

*f. Blank making*

During the assembling process of bamboo curtain plywood, the board close to the surface of bamboo curtain should be doubly glued, while the core board should not be glued. The planning side of bamboo curtain plywood can also be spread with a thin layer of glue and then be assembled together. When hollow bamboo curtain plywood is assembled, both the top and bottom surface of the three or four scantlings (four is best) which make up the frame in the core layer should be glued. Meanwhile, a thin layer of glue should also be spread at the place which is corresponding to the surface board of bamboo curtain and where it is glued with the scantlings in order that they are finely glued. Once the corresponding places of the scantlings and the surface board are fixed on, we hole the plywood with a jackhammer and then fix positions with those whittled bamboo nails. Usually, we drive in seven to twelve glued bamboo nails along the vertical length (2 – 4m), which is convenient for transporting and two time's shaping process.

*g. Shaping through hot-pressing*

Since hollow panels of bamboo curtain plywood and panels of bamboo curtain plywood are planed or sanded, when they are shaped, we can use a lower pressure, usually a pressure around 1.5 MPa. In this way, we can on one hand guarantee the gluing, on the other hand reduce the compression ratio. In the process of hot-pressing, the temperature should be 130°C, and the time is 0.8 minute for every millimeter of panel.

*h. Process at the later stage*

When used as flooring of railway flat car, the floors of bamboo-wood compound assemblies with bamboo curtain plywood should be cut into three hundred-millimeter-wide boards. Then after paring with required thickness and milling, they can be made into products which can be used in railway flat cars. Hollow panels also need to go through such processes as surface planning and paring, edge milling, port painting, etc. at the later stage.

### Physical and Mechanical Properties of Bamboo-wood Plywood

*a. Physical and Mechanical Properties of Solid Bamboo-wood Plywood*

As a loading equipment of railway flat car, the plywood is required to have such properties as high vertical strength, certain horizontal strength and good impact tenacity and aging resistance as well as relative easiness of being nailed and good nail-

holding power. See Table 4.7.

**Table 4.7 Physical and Mechanical Properties of Floors of Bamboo-wood Compound Assemblies with Bamboo Curtain Plywood**

Serial number	Item	Unit	Standard	Testing method
1	density	g/mm	≤0.8	GB/T4897.5.2
2	Moisture content	%	≤12	GB/T4897.5.3
3	Bending strength (vertical)	MPa	≥70	GB/T4897.5.7
4	Bending strength (horizontal)	MPa	≥10	GB/T4897.5.2
5	Elastic modulus	MPa	≥6000	GB/T4897.5.8
6	Impact tenacity	kJ/m <sup>2</sup>	≥80	GB/T 1940
7	Pressure-Resistance strength	MPa	≥10	GB/T 1939.6
8	Nail-holding power	Newton	≥1400	GB/T4897.5.9
9	Bonding strength	MPa	≥1.0	LY/T 1055.6.2.2
10	Bending strength After acid-resisting	MPa	≥40	Bend after dipping into 5% HCl for seven days
11	Bending strength After alkaline-resisting	MPa	≥40	Bend after dipping into 1% NaOH for seven days
12	Low temperature impact tenacity	kJ/m <sup>2</sup>	≥60	- 50 degrees centigrade, impact after three hours
13	Heat resistance		no cracking or deguming	120 degrees centigrade, observe after three hours
14	Bending strength After aging resistance treatment	MPa	≥60	Dip into 25°C water for 16 hours, bend after finishing four cycles of drying for 8 hours in a 65°C drier

Remarks: the standard number above is from the diagram of enterprise standard system "bamboo-wood plywood for railway flat car" which is established by Railway Department QiShuYan Motor vehicle company and Bamboo Project Research Center of Nanjing Forestry University in 1997.

#### *b. Quality Standard of Hollow Bamboo-wood Plywood*

**Strength standard.** hollow bamboo-wood plywood is mainly used as scaffold board for shipbuilding. Its mechanical properties include:

a) Stiffness testing: to test deflection in a set span, weight and loading focused on the central part: for deflection standard of scaffold board for shipbuilding. see Table 4.8.

b) Dead load testing: with a maximal load of 450 kg, take a five-minute hydrostatic testing of the plywood. After unloading, no deguming, cracking or serious surface damage is allowed.

c) Dynamic load: in the test, lift an object of 75 kg up to a point which is 2.5 m higher than the scaffold board and let it fall freely to the plywood. Likewise, no deguming, cracking or serious surface damage is allowed.

**Weight requirement.** scaffold board for shipbuilding has strict requirement on its strength as well as its weight. Standard weight is as follows:

Length L = 3m. Weight W ≤ 23kg. ; Length L = 4m. Weight W ≤ 33kg.

**Table 4.8 Deflection Standard of Scaffold Board for Shipbuilding**

Load (kg) Deflection standard (mm) Board length (m)	75	150	225	Remarks
2	3.5	7.0	10.5	Thickness of board: 50 mm
3	8	16	24	Thickness of board: 50 mm
4	12	24	36	Thickness of board: 60 mm
Remarks: width of board: 300 mm				

## 4.6 Production of Bamboo Floorboard and Pavement Technologies

Bamboo floorboard is formed of bamboo strips of pre-determined width and thickness, and is manufactured by means of double direction hot pressing and adhering. It is utilized to substitute for valuable timber, which is a kind of proper material with stable dimensions, fine grain, excellent structure and high mechanical properties.

### 4.6.1 The Structure and Classifications of Bamboo Floorboard

According to its structure bamboo floorboard can be sorted into the following types: radial-cut face (side pressed), chord-cut face (right pressed, lengthwise core layer

and crosswise core layer), bamboo-wood composite (right pressed, lengthwise core layer and crosswise core layer). Samples of these types of floorboards are shown in Figure 4.21.

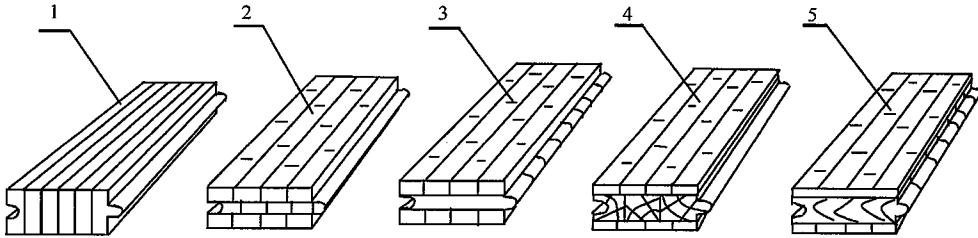
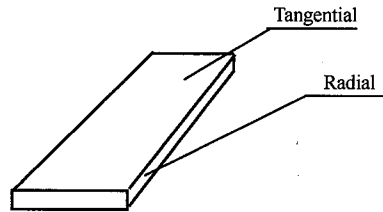

**Figure 4.21** The Structure of Bamboo Floorboards

1. Radial-cut face (side pressed)
2. Chord-cut face (right pressed, lengthwise core layer)
3. Chord-cut face (right pressed, crosswise core layer)
4. Bamboo-wood combined (right pressed, lengthwise core layer)
5. Bamboo-wood combined (right pressed, crosswise core layer)

According to the structure of bamboo culm, the width of a bamboo piece is its chord-cut face, while its thickness is radial-cut face as shown in Figure 4.22.

Radial-cut face floorboard is made of many bamboo pieces, their chord-cut faces are coated with adhesive and pressed together, such floorboards are called side pressed boards. The width of a bamboo piece equals to the thickness of the floorboard, and the combined thickness of many bamboo pieces' radial-cut face equals to the width of the bamboo board. Chord-cut face floorboard consists of surface layer, core layer and back layer. Pieces in the same layer are joined with their radial-cut faces, and pieces of adjacent layers are connected with their chord-cut faces. Such floorboards are also called right pressed boards. The green surface part of a bamboo culm is of fine and close texture, with good-looking grain. On the contrary, the yellow surface part is of loose texture, with monotonous grain. For the sake of symmetric structure, stable dimensions and fine appearance, the green part of bamboo culm pieces in surface and back layers must be arranged outwardly. There are two kinds of radial-cut face floorboards. One is lengthwise core board, in which the grain of bamboo pieces for core layer is in the same direction as that of surface and back layers and they are glued and made blank. The other is crosswise core board, in which the grain of core layer is perpendicular to grain of surface and back layers and they are glued and made blank. As for bamboo-wood composite

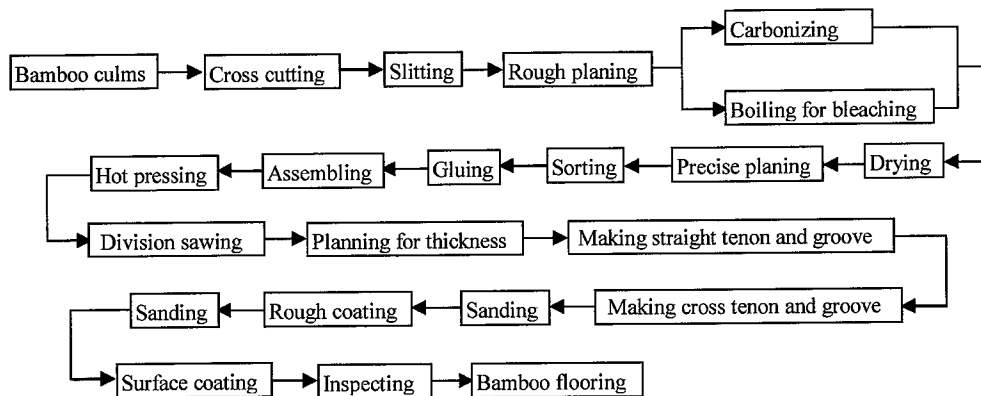

**Figure 4.22** Chord-cut and Radial-cut Faces of a Piece of Bamboo Flooring



floorboard, the surface and back layers are made of bamboo pieces of 3.0 – 3.5 mm in thickness, the core layer is sawn wood board of lower density, 10 – 12 mm in thickness. The bamboo pieces on the surface and back layers could be made from thick pieces in bottom part of a culm, which can be cut into two pieces with slicing saw, or directly from the thinner pieces near the top part of bamboo culm. Bamboo-wood composite floorboard could also be divided into lengthwise core board and crosswise core board. Bamboo-wood composite floorboard possesses nice appearance of bamboo and features of wood floorboard. It is advantageous in using fast-growing culms of lower price and large yields, and with better performance-price ratio.

In terms of the color, bamboo floorboard can be divided into natural colored floorboard and carbonized floorboard. natural colored floorboard are boiled and bleached, and as a result, the original color of bamboo is retained. Carbonized floorboard is carbonized at a high temperature, under the treatment of high-pressure saturated steam. So its color turns into coffee brown, which makes the name of carbonized board.



## 4.6.2 The Processing Technology of Bamboo Floorboard

### 4.6.2.1 Technological process of production

As a new decorative material, bamboo floorboard manufacturing has strict requirements in material selection and processing technology. Here is the flowing chart of its technological process:

### 4.6.2.2 Technological requirements for major procedures

#### a. Raw materials

Select fresh bamboo of 4 or more years old and the diameter of raw bamboo for floorboard production should be more than 10 cm. The culms should be straight, with thick walls and low sharpness. The bending, mildew culms with insect holes

would greatly decrease the utilization rate and are unsuitable to produce floorboards.

*b. Cross cutting*

To cut off the slanted cutting at the bottom of raw bamboo left during culm harvesting, forming a new smooth end.

To start the cutting operation from the new end, cut sections of pre-determined length.

During the cross-cutting of bamboo culms with great crookedness, it is better to make shorter sections. In case of cracks the cracked parts must be cut accordingly, without affecting the use of other parts.

The culm sections must have enough margins for processing. In general, if the length of finished floorboard is 910 mm, the section length should be 950 mm, if the length of floorboard is 610 mm, the section length should be 650 mm. The rational margin in length is 40 – 50 mm.

The culm wall near the top is thinner, therefore this part of bamboo is not fit for making pure bamboo floorboard. If the wall thickness is less than 7 mm, it can be applied to make chopsticks, bamboo skewers, toothpicks, bamboo curtains, or thin bamboo pieces for bamboo-wood composite floorboards.

*c. Lengthwise cutting*

Use coaxial double disc-saw to cut bamboo strips of same length and same width. The clearance between disc saws, which could be adjusted, would decide the width of bamboo strips. The wider the strips, the more the amount of green and yellow matter is cut off, the lower the utilization ratio. But if the strips are too narrow, the loss of sawn dust also increases. Therefore the width of strips must be determined rationally. Generally speaking, for making radial-cut face board, the rational width is 25 mm. and for chord-cut face board the width of strips is 19 mm. In lengthwise cutting, the small end of culm must be put as the forward end to avoid the width shortage of the last strip.

*d. Rough shaving*

If the green and yellow matter remains on the faces of strips, the chemicals can hardly permeate into the strips during boiling and bleaching. In addition, green and yellow matter also affects the efficiency of adhesive for normal bonding. For the sake of further processing the green and yellow matter on both faces of bamboo strips must be removed and the cross section of the strip must be shaped into rectangular.

This operation is carried out on a rough shaving machine. First of all, remove the residual inner joints with a knife, then sort the strips into groups of different

---

thickness, as a rule, two or three groups. Adjust the cutting thickness of rough shaving machine according to the dimensions of strip and begin the rough shaving. Pile the shaved strips and bundle them up. Rough shaving means to make the surfaces roughly even, the residual green and yellow matter should not exceed 30%. The shaven amount should not be too much, enough margins for further processing must be guaranteed.

*e. Boiling and bleaching*

The content of protein in bamboo culms is about 1.5% – 6.0% , carbohydrate about 2% , starch 2.0% – 6.0% , fat and wax 2.0% – 4.0% . Stored under ordinary temperature and humidity, the strips will be attacked by insects and/or become mildew. The duration of floorboard should be long and the appearance of it should remain nice. The floorboard's life would definitely be affected by insufficient treatment. Therefore, in producing bamboo floorboard great attention should be paid to the prevention of insect and mould damages. There are two prevention methods used in production: boiling-bleaching and carbonization. Boiling-bleaching is an essential part of technology for manufacturing natural colored floorboard. It is to drain all the soluble organic matter from raw material and to kill insect ova and fungi by means of boiling with bleacher, insecticide, pesticide and preservatives ( see Figure 4.23). Besides, thanks to the bleacher, different colors of various strips at different ages or places tend to be identical. Thus the whiteness of floorboard enhances and the color difference reduces.

The practical operation is as follows: Put roughly shaved bamboo strips into warm water of 60°C , add hydrogen peroxide (30%) , insecticide and preservative, the amount is 5% – 8% . Boil the water with steam for 6 – 8 hours. Take out the strips after boiling, the water in boiling basin can be used further, but the above-mentioned chemicals must be added with the progress of the boiling operation.

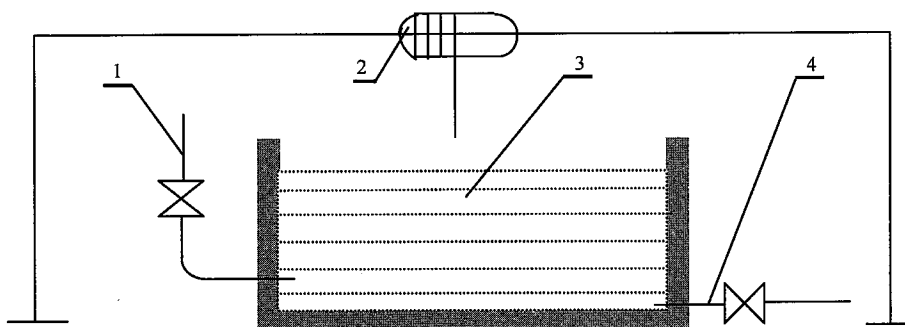
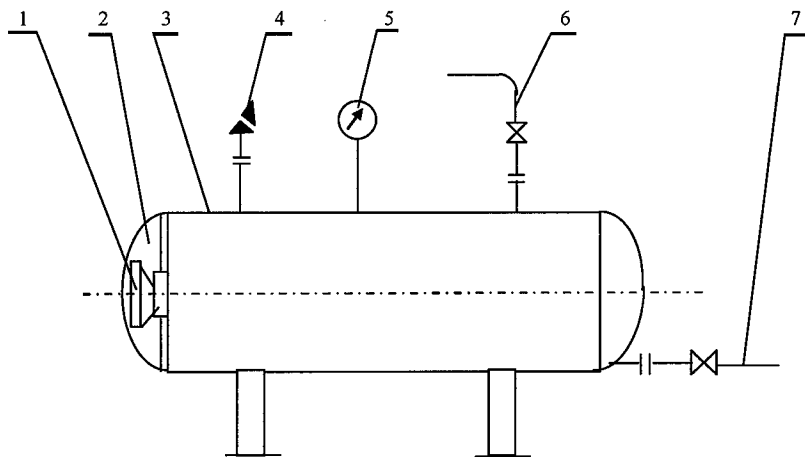

**Figure 4.23** Scheme of Boiling-bleaching

1. Steam pipe 2. Crane 3. Boiling-bleaching basin 4. Drain

### f. Carbonization

The concept of carbonization is like this; Put bamboo strips under the conditions of high temperature, high humidity and high pressure. Decompose the organic matter, such as carbohydrate, starch and protein, and kill the ova and fungi. The color of carbonized bamboo fiber turns into brown. As the soluble organic matter has not been drained from bamboo material during carbonization as it has happened in boiling-bleaching, the specific gravity of carbonized strips is a little higher than that of boiled-bleached ones. Carbonization of bamboo fiber under the conditions of high temperature and high pressure does not affect the strength of the material greatly (reduced a few in general), but the rigidity of surface is a little higher. The carbonizing operation is to load roughly shaved strips into special carbonizer and fill it with steam to keep proper pressure (see Figure 4.24). First of all, put bamboo strips into a metal basket, move it along a rail into the furnace and close the door. Open the steam valve, raise the pressure to about 0.3 MPa and keep it for 70 – 90 min.



**Figure 4.24** Carbonizer

1. Handwheel 2. Furnace door 3. Body 4. Safety valve 5. Pressure gauge  
6. Inlet steam pipe 7. Outlet steam pipe

### g. Drying

The drying of strips is an important step in the production of combined bamboo and bamboo floorboard. The effects of drying operation are as follows: 1. Prevent the shrinkage, cracks and deformation of floorboard in its use. 2. Prevent the growth of insects and fungi effectively. 3. Create favorable conditions to improve adhering strength. Therefore, this operation must be carried out carefully and strictly. The moisture content of strips after drying should be about 8%.

The water content of strips after boiling-bleaching and carbonization is about 35% – 50%. The fibers of bamboo are arranged in order, and the strips are of small

size. In the process of drying bamboo strips will not be cracked or warped, which are often seen in wood drying. Consequently the technology of bamboo drying is much simpler than that of wood drying. It is unnecessary for such tasks as steaming, humidifying, and operating with complex temperature curve. In general, keep the temperature within the range of 60 – 70°C for 72 – 84 hours, hence the water content can be reduced to less than 10%. But the temperature should not exceed 70°C, otherwise strips will be warped and floorboard deformed.

For the rational utilization of processing wastes, all the bamboo wastes can be used as fuel of stove for drying. The effect is also satisfactory.

#### *h. Precise shaving*

For the sake of good appearance and accuracy, the width and thickness of strips must meet the requirements so as to make the adjacent strips join closely and correctly before the hot pressing. This will be achieved by means of precise shaving, which is performed on a precise shaving machine. The upper and lower hobs of the shaving machine are used to process the chord-cut faces (the green and yellow faces), while the left and right hobs are to process the radial-cut faces. The correct width and thickness are achieved by adjusting the clearances between upper and lower hobs, and between left and right hobs, respectively. Attention must be paid to the following points: 1. Remove all the green and yellow matter, otherwise it may affect adhering strength. 2. Make every part of the surface of strips even, some of them shrink more than others, therefore the clearance between hobs must be adjusted correspondingly. 3. The specification of dimensions should not be too many. Strips must be piled according to their dimensions for blank making. 4. The error of precisely shaved thickness and width must be kept under 0.1 mm.

#### *i. Blank making and hot pressing*

This operation is implemented to assemble the board flange and glue to board in accordance with the structure of final products. The following is specific procedures:

**The preparation of adhesive.** The adhesive applied for making bamboo floorboard is thermosetting urea-formaldehyde resin. The ordinary urea-formaldehyde resin contains certain amount of free formaldehyde, which is harmful to human body. Consequently, there are rigid restrictions and strict regulations on the release of free formaldehyde both in China and abroad. So it is recommended to select urea-formaldehyde resin with little free formaldehyde.

Urea-formaldehyde resin must be added with curing agent before hot pressing. Curing agent can be added to emulsion resin directly and mixed evenly. If the curing agent is in powder form, it must be dissolved in water at first, then added to resin and mixed.

**Adhesive coating.** Bamboo strips must be coated with adhesive before hot pressing. For strips of surface and bottom layers the yellow face and both radial-cut faces are to be coated. As for strips of core layer, all the four faces must be coated evenly. The strips can be coated by means of a coating machine or manually. But if a coating machine is used, the radial-cut faces must be coated manually at first, and then the chord-cut faces by machine.

**Blank making.** Coated strips are assembled in accordance with the pre-determined specifications and structure of final products. The board flange is formed by combining surface, core, and back layers of strips. Single piece or a complete piece can be made according to the width of the hot pressing.

For producing chord-cut face boards with lengthwise layer, the strips of adjacent layers must interlock with each other to avoid the crosswise warp showed in Figure 4.25.

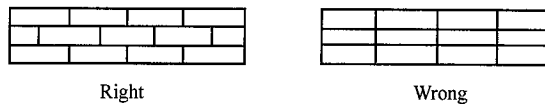

Figure 4.25 Modes of Assembling for Bamboo Strips

**Hot pressing.** After the procedure of assembling, the bamboo strips should immediately be moved into the hot pressing machine piece by piece to be heated and pressed. When the board flange reaches the working pressure, the adhesive would rapidly solidify under the heat and pressure, and the bonding process is finished. The operational steps are as follows,

- a) Heat the platens to about 100°C.
- b) Arrange the board flange on the platens in proper order.
- c) Close platens.
- d) Apply side pressure to eliminate side chinks between bamboo strips in lateral direction (to be observed by naked eye).
- e) Impose straight pressure once again until the board flange becomes totally straight with tight bonding.
- f) Keep the straight and side pressure for 10 minutes till the curing of adhesive.
- g) Release the straight and side pressures and unload the board flange.

*j. Abrasive planing and sanding*

The precise shaving of bamboo strips needs certain margins. So the thickness of board flange will be 1 – 1.5mm larger than that of the final product. Besides, the unevenness of platens and ooze of adhesive may cause rough surface of a board flange after being heated. Therefore, it is necessary to level both sides of board flange with a

sanding machine to reach a final thickness slightly larger than that of floorboard. Sanding often starts from the board surface to get rid of the oozed adhesive, residual of green matter and pressed trace. But the volume of shaving should not be too large, otherwise the bamboo fiber structure far from the green bamboo strip would be loose with dull veins. To smooth the board is preferred because the bamboo fiber structure near to the green bamboo strip would be tight with refined veins and delicate shape. The rest of processing margin can be moved by bottom shaving.

*k. Making groove and ridge-sized tenon*

Like the traditional wood floorboard, bamboo floorboard is always in rectangle shape. The paving work aims at conjoining boards into a whole, thus the groove and ridge-sized tenon should be designed on four edges of the board. The groove and tenon on lengthwise edges are called side groove and side tenon while that on crosswise edges are called end groove and end tenon. Convex one is male and concave one is female.

The cutting should begin with side groove and side tenon, and then end groove and end tenon, to guarantee the accuracy of flooring. This operation is conducted on a high-accuracy four-sided planer. First, adjust the planer into precise size of floorboard; second, load the shaved, trimmed board flange one by one into the delivery system of the planer. With its cutter axis revolving up and down, left and right, the planer would grind the top side and reverse side of floorboard into the required thickness, and at the same time mill the two-sided male and female grooves.

The end groove and end ridge-sized tenon are normally processed with double-headed milling machine, whose working procedures are like this: the transmit system automatically delivers the board flange fixed on the working plate under the round saw blades symmetrical up and down, left and right; the blades cut the board flange into fixed length; the flange keeps going forward and is milled by milling cutter of main axis to come out of the groove.

*l. Painting*

Painting is the last procedure in the bamboo floorboard processing with three objectives. The first is to enhance the hardness of floorboard surface to prolong its duration. The abrasion resistance of painted board can be 2,500 rpm with bottom unchanged. In normal cases, the paint of floorboard would not peel off for 15 years, with relatively low rate of surface abrasion. The second is to beautify the floorboard. The painted board becomes smooth, shiny and facilitates cleaning. The third is to seal the floorboard and make it moisture-proof. Before the solidification, the molecule of paint has already filled up the pores of bamboo texture. After the curing, a layer of hard covering film is formed to keep the air moisture from penetrat-

ing into board. Therefore, the change of environmental moisture will not lead to swelling, shrinkage and avoid to producing insects and fungi. Hence, the painting quality of bamboo floorboard, which directly relates the board's appearance and duration, is a significant task in the production processing.

Thermoset resin paint and UV curing resin paint are usual choice of bamboo floorboard painting, but they differ in raw materials and technological process of painting. Currently, the majority of production companies use UV curing resin paint.

#### **4.6.2.3 Paving and maintenance of bamboo floorboard**

This paint-free and shave-free board does not need complex procedures of sanding, painting, etc while being floored. It can be used immediately after flooring, quite simple and convenient. But due to its delicate and precise processing, there is a high level of accuracy demand for flooring work. So, accurate flooring and regular maintenance serve the pre-conditions in maximizing the superior quality of bamboo floorboards, prolonging its duration and beautifying the household life.

##### *a. Proper places for bamboo floorboard use*

As a high-class decoration material, bamboo floorboards, in recent years, have been extensively applied in households, office buildings, guesthouses, recreational and sports places, and are favored by the consumers. Theoretically speaking, it is suitable for any indoor places that are well ventilated, dry and easy for maintenance. This product can be used in various places of different climate conditions, including coastal areas of high-temperature and high-humidity. Customers can choose to use it without concerns. To make it more specific, the following places are favorable for using bamboo floorboards:

**Household decoration.** This is the most common place for bamboo floorboards, especially in living rooms, studies, gyms, etc.

**High-class office buildings.** The range covers office rooms, meeting rooms, reception rooms, exhibition halls, etc.

**Guesthouses, hotels.** Includes the suites of guesthouses, health center, entertainment center, meeting center, etc.

**Top-grade department stores.** Including halls, franchised counters, etc. It's also applicable for wall decoration.

Some places that unsuitable for bamboo floorboards, such as ground floor and basement of buildings with insufficient moisture prevention, ground surface often watered, public indoor places of large area, public passages.

The paving of bamboo floorboards is usually arranged as the last procedure in interior decoration, otherwise other works may destroy or pollute the boards.

---



*b. Paving methods and procedures of bamboo floorboards*

**Moisture proof.** The first step is to cover the ground with a layer of moisture-proof material, like asphalt felt and plastic film. These materials should be complete, with overlapped covering in the torn parts or joints. This layer is to prevent the condensed vapor on ground from directly contacting the back of board. The vapor will evaporate through the edges at the wall corners. Moisture proof treatment is especially important for newly-built structures' decoration.

**Keels lying.** Unlike other kinds of bending floorboards, bamboo boards must be supported and fixed by keels. The first step is to select good wood for keels, like pine, Chinese fir, broadleaf wood species, but those tending not to decay with high nail holding power are preferred. Specification of a keel is 30mm × 30mm. The length depends on the area of floor. The selected keel wood should be artificially or naturally dried, and then be shaved into same thickness with four-sided planer or press planer. Keels should be laid in the crosswise direction of the room. The distance between neighboring parallel keels is about 300mm based on the actual length of floorboard. The ends of floorboards should be put over the keels, not suspending in midair. The fixed keels should be adjusted with a level. Put a piece of wood under on the lower places, and firmly nail the keel onto cement ground with 5cm long cement nails.

Some customers like to cover another layer of plywood or medium density fiberboard on the keels. But if the ceiling of the room is not high enough or the budget is limited, such a cover can be neglected, and the quality of floor will not be affected.

**Floorboard paving.** Bamboo floorboards are to be paved in the form of staggered joint, just as the bricks laid in a wall. That is, to stagger the joint crevice of groove and tenon ends with the adjacent ones, thus make every other joint crevice in a same line. This kind of assembling method enables crevices evenly distribute on a surface to enhance its stereoscopy. While the width and length of floorboard are not in even times with room sizes, floorboard can be sawed apart. But the saw edge should be coated with a layer of varnish to seal it from moisture.

Here are methods of fixing floorboards with keels: At the base part of male tenon along the length of floorboard, penetrate a 2.5 cm long iron nail through the floorboard into depth of keels at an angle of 45°. In this way the floorboards and ground tightly combine into a "whole". Before hammering, drill a small leading hole on board, thus the nailing would not crack the board. The reason is the bamboo, which has no horizontal fibers, tends to crack vertically.

Another point needs to be highlighted. The ends of floorboard should be 1 – 2 cm away from room's walls, keeping the moisture of wall from entering the floor-

board. The remaining seams can be covered with skirting to keep the decorative effect.

*c. Maintenance of bamboo floorboards*

Correct usage and maintenance are crucial for the appearance and duration of bamboo floorboards. With the development of bamboo industry in recent years, more and more consumers have adopted bamboo floorboards with the increasing approval of this product. However, problems sometimes occur because of the lack of maintenance knowledge for some users. The following points should be noticed during the daily use of bamboo floorboards:

**Keep a well-ventilated and dry indoor environment.** A frequently ventilated room quickens the chemicals of floorboards volatilizing to the outside, and exchanges the air inside and outside the room to keep the fresh air. It is essential for a room without being lived for a long time. To create a dry and clean indoor environment, the basic method is to frequently open the windows or doors to make air circulate, or exchange air through air adjusting system.

**Avoid sunshine or raindrops.** For some houses and rooms, sunshine or raindrops can get into indoor through windows, which generate damage to the bamboo floorboards. Sunshine would speed up the ageing of paint and glue, and cause the shrinkage and cracking of the floorboards. If wetted by rain, bamboo would absorb the moisture to swell, even go moldy. Special attention must be given in this aspect.

**Avoid damaging the surface of floorboard.** The painted surface of bamboo floorboard serves as a decorative layer as well as a protective layer. Therefore, avoid hitting it with hard objects, or scratching it with sharp tools, or grinding it with metals. Chemicals should not be kept in the room either. Besides, ones should lightly move or put the furniture inside the room. Put rubber pieces under the furniture foot. In the public places, carpets should be laid in the major passageways.

**Correct ways of cleaning.** Regular cleaning of floorboards is necessary. Sweep the dust and other dirty things away with a clean broom, and wipe it with a wrung-out soaked rag. If the board is large, wash a cloth mop and hang it up to drip it out, then mop the board. Do not wash it with water directly nor clean it with wet rag or mop.

If possible, users are suggested waxing the floorboard once in a while to protect it. Damaged paint surface can be made up with varnish by users themselves or repaired by board manufacturers.

---

# CHAPTER 5

## Production Technologies, Properties and Utilization of Bamboo Charcoal

### 5.1 Preface

The fast-growing bamboo normally achieves its maturity after 4 to 8 years (clumpy bamboo gets mature earlier than running bamboo), when it has the highest volume weight and mechanical strength, thus it is the most suitable age for bamboo industry. Once bamboos form a forest, they can be felled via selection gutting year by year and be utilized continually. Therefore, bamboo is a kind of renewable biological resources to be managed in a sustainable manner.

China is one of the distribution centers of the world bamboo forest with 500 species under 39 genera approximately, taking up one third of the world's total bamboo species. Currently, there is a bamboo area of 7.2 million ha in China, among which, 4.21 million ha is pure bamboo forest, and the rest is mixed forest and high-mountain bamboo clump.

Since the 1980s, the gradual decrease of tropical forest urges the bamboo production countries to pay attention to bamboo processing. As a particular case, China's bamboo processing and utilization have switched from the traditional handicraft to the mechanized production. Various types of man-made bamboo boards, such as bamboo plywood, bamboo laminated board, bamboo composite board, bamboo floorboard, bamboo decorative sticking panel, have developed rapidly and formed a processing industry with certain scale.

But most man-made bamboo boards cannot utilize the "whole bamboo" but the middle section of bamboo culms. In addition, a large number of small diameter bamboo and thin-walled clumpy bamboo are not suitable for producing bamboo-based board. The chemical processing of bamboo not only utilizes the "whole bamboo" but also covers every bamboo types. A variety of clumpy bamboo species can be used to produce bamboo charcoal. This technology has drawn attention from

more and more people. At present, major methods of chemical processing of bamboo are bamboo-leaf extract and bamboo high-temperature pyrolysis. The latter, producing bamboo charcoal and bamboo vinegar via pyrolysis has been proved to be an efficient way of making use of “whole bamboo”. Besides, the processed residues, like man-made bamboo boards and many daily use bamboo products, such as bamboo chopsticks, bamboo mat, bamboo toothpick, fragrant bamboo sticks can be processed into bamboo compressed charcoal through a series of procedures. A new way has been explored, because of the development of bamboo charcoal and its products, for efficient use of bamboo and expansion of its usage areas.

## 5.2 Introduction of Bamboo Charcoal

Similar with wood charcoal, bamboo charcoal is a kind of microporous material with high surface area that has strong absorption ability. Theoretically, there are two kinds of absorption function for bamboo charcoal, namely, physical absorption and chemical absorption. The absorption force involved in physical absorption is physical, mainly under the impact of van der Waals forces. The configuration of absorption molecules and solid surface will not change in physical absorption. In chemical absorption, the chemical action, like the exchange, transfer, sharing of electrons between absorption molecules and solid surface would lead to re-arrangement of atoms, the formation or damage of chemical bonds.

The physical absorption is fast, reversible, non-selective, and noticeable in low temperature. It happens in ways of monolayer or multiplayer, since van der Waals forces still impact on a layer of absorption molecule.

The speed of chemical absorption is like that of chemical reaction. The chemical absorption in need of activation energy is often fast only in high temperature. It is usually irreversible, and accompanied with product precipitation of chemical actions. Chemical absorption is monolayer, with obvious selectivity.

The electric conductivity of bamboo charcoal increases with the final temperature of carbonization. While the carbonization temperature is 700°C, its electric resistivity is weak as  $5.40 \times 10^{-5} \Omega \cdot m$ , showing favorable electric conductivity. Thus the bamboo charcoal is of good electromagnetic shielding property.

As the global industrialization accelerates its pace, the issues of air pollution and water pollution are becoming increasingly serious. Bamboo charcoal, a new environmental-friendly material, has developed rapidly in recent years. The reasons are as follows: ① The wood resources to produce high quality charcoal is decreasing sharply, nearly exhausted. ② Bamboo is fast growing, abundant, short in harvest cycle. Burning bamboo charcoal is environmental friendly. ③ The properties of bamboo charcoal are similar to those of charcoal made from hardwood, being an

---

ideal substitute for top-quality wood charcoal. ④ The hardness of bamboo charcoal facilitates processing and formation.

Currently, a series of products has been manufactured on the basis of the supreme absorption function and far infrared creation of the bamboo charcoal. These products cover areas like water and air purifying, room dehumidifying, healthcare, deodorizing and handicrafts. The electromagnetic-shielding and radio resistant products making use of its electromagnetic shielding property are still under the research.

### 5.3 Classifications of Bamboo Charcoal

There are many ways of classifying bamboo charcoal, based on the different shapes of charcoal and raw materials, usages and burning temperatures of charcoals.

Bamboo charcoal can be classified into following groups according to its shape :

① Raw bamboo charcoal ( See Figure 5. 1 ). The bamboo is cut into sections and is put into kiln, and then the charcoal can be got after the pyrolysis without air or with little air inside the kiln. ② Compressed charcoal ( See Figure 5. 2 ). The processed residues are used as raw material, which undergoes smashing, drying and modeling. Then the charcoal can be got after the pyrolysis without air or with little air inside the kiln.

Classifications can be made according to the shape of bamboo charcoal, as round charcoal, slice charcoal, powder charcoal, particle charcoal, etc.

Classifications can be made according to the usage property of bamboo charcoal, as absorption charcoal, anti-electromagnetic radiation charcoal, radioactive infra-red charcoal.

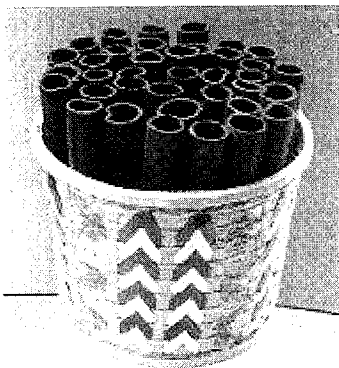

**Figure 5.1** Raw Bamboo Charcoal



**Figure 5.2** Compressed Charcoal

Classifications can be made according to the burning temperature of bamboo charcoal, as high-temperature charcoal, medium-temperature charcoal, low-temperature charcoal.

In light of usage of bamboo charcoal, there are water purifying charcoal, room dehumidifying charcoal, deodorizing charcoal, healthcare charcoal, agroforestry charcoal and barbecue charcoal. As there is no national unified standard, the terminologies of bamboo charcoal may vary in different areas.

## 5.4 Theoretical Basis of Bamboo Pyrolysis

The bamboo pyrolysis is the process in which bamboo is heated, decomposed in absence of air or with little air. The pyrolysis includes bamboo carbonization, bamboo distillation, bamboo-based activated carbon manufacturing, bamboo gasification, etc.

**Bamboo carbonization:** bamboo is pyrolyzed in brick kilns or mechanical furnaces by burning firewood or coal with little air to produce bamboo charcoal.

**Bamboo distillation:** bamboo is heated in a pyrolyzing kettle in the absence of air to produce bamboo charcoal, bamboo vinegar, etc.

**Bamboo-based activated carbon manufacturing:** the bamboo material is heated in a brick kiln or activated furnace to produce bamboo-based activated carbon.

**Bamboo gasification:** bamboo or bamboo residues are heated to generate bamboo gas in a gasification kiln.

### 5.4.1 Stages of Bamboo Pyrolysis

Bamboo pyrolysis can be divided into four stages based on the processing temperature and the product condition in the pyrolysis.

**First stage—drying:** the temperature is below 120°C and the pyrolysis speed is very slow in this stage. Relying on the external heat, the moisture in bamboo evaporates, and the chemical composition of the bamboo remains intact. Accordingly, this stage is an endothermic (i. e. absorbing heat) reaction and water is the main product in this stage.

**Second stage—pre-carbonization:** the temperature is in the range of 120°C to 260°C and there is a distinct pyrolysis reaction in bamboo during this stage. The unstable chemical compounds in bamboo (i. e. hemicelluloses) begin to decompose into carbon dioxide, carbon monoxide, small molecule vinegar, etc. This stage is also an endothermic reaction.

**Third stage—carbonization:** the temperature ranges from 260°C to 400°C, and the bamboo is rapidly decomposed into many products. Liquid products contain acetic acid, methanol, and bamboo tar. Flammable methane and ethylene in gas prod-

ucts are increasing while carbon dioxide is decreasing gradually during this stage. This stage is an exothermic reaction.

Fourth stage—calcinations (refining stage): the temperature is over 400°C. The external heat is utilized to calcine the bamboo charcoal, emitting the volatile substances remained in the charcoal to enhance non-volatile carbon content. There are few liquid and gas products in this stage. Refining stage is key to decide the grade of bamboo charcoal. Based on the temperature in this stage, the bamboo charcoal can be divided into three groups: high-temperature charcoal, medium-temperature charcoal, and low-temperature charcoal.

It should be noted that it is difficult to differentiate these four stages because different parts in the pyrolyzing kettle are heated differently. With low thermal conductivity coefficient, the bamboo culms might stay in different pyrolysis stages in different parts of a pyrolyzing kettle (the top or the bottom). This difference might happen between the outer and the inner parts of bamboo culms. However, the distinct change of temperature during the exothermic reaction stage is quite obvious in an intermittent pyrolyzing kettle in which the temperature in the pyrolyzing kettle is going up rapidly while heating power keeps stable.

#### 5.4.2 Products of Bamboo Parolysis

There are three groups of pyrolysis products: solid (bamboo charcoal), liquid (bamboo vinegar), and gas (bamboo gas) products.

In the laboratory, bamboo distillation is carried out in a one-kilogram-retort for 8 hours. Products of bamboo pyrolysis are shown in Table 5.1 and Figure 5.3.

**Table 5.1 The Contents of Bamboo Pyrolyzed Products at the Terminal Temperature of 500°C**

Bamboo charcoal	Crude bamboo vinegar	Bamboo gas	Loss
30%	51%	18%	1%

Note: Percentage refers to the percent of products made from oven-dry bamboo.

##### 5.4.2.1 Solid products

The bamboo charcoal is the solid product left in the pyrolyzing kettle after the bamboo pyrolysis. The bamboo charcoal has micro-hole in structure with excellent adsorption capability.

##### 5.4.2.2 Liquid products

Vapor and gas compounds are collected by the pyrolyzing kettle and condensed into liquid products (bamboo vinegar) and gas products (non-condensed gas or bamboo gas).

Crude bamboo vinegar is a kind of brown-black liquid containing more than

300 organic compounds apart from a large quantity of water (include reaction water). Some of the compounds are as follows:

**Saturated acid.** Acetic acid, formic acid, propanoic acid, and butanoic acid.

**Unsaturated acid.** Crylic acid ( $\text{CH}_2 = \text{CHCOOH}$ ).

**Hydroxyl-acetic acid.** 2-hydroxyl-acetic acid ( $\text{CH}_2\text{OHCOOH}$ ).

**Heterocyclic acid.**  $\beta$ -furan-carboxylic acid ( $\text{C}_4\text{H}_3\text{OCOOH}$ ).

**Saturated alcohol.** Methanol.

**Unsaturated alcohol.** Allyl alcohol ( $\text{CH}_2 = \text{CH CH}_2\text{OH}$ ).

**Ketone.** Acetone, methyl ethyl-ketone, methyl propyl-ketone, and cyclopentanone.

**Aldehyde.** Formaldehyde, ethyl-aldehyde, and furoal.

**Ester.** Methyl formate, methyl acetate.

**ArOH.** Phenol, methyl-phenol, and O-benzene-diol.

**Lactone.** Butyrolactone.

**Aromatic substance.** Benzene, toluene and naphthalene.

**Heterocyclic compounds.** Furan, and  $\alpha$ -methyl furan.

**Amine.** Methylamine.

The crude bamboo vinegar can be divided into two layers while settling. The upper layer is clarified vinegar, and the lower layer is sediment tar.

The clarified vinegar is a light yellow or light brown liquid with special scent.

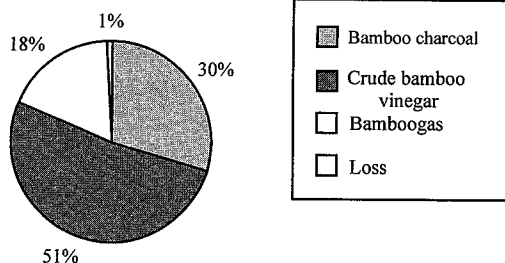

Figure 5.3 Contents of Pyrolyzing Bamboo at Terminal Temperature of 500°C

#### 5.4.2.3 Gas products

The bamboo gas obtained from bamboo pyrolysis is mainly composed of carbon dioxide, carbon monoxide, methane, ethylene, hydrogen, etc. The bamboo gas can be used as fuel.

## 5.5 Production Equipment and Technology of Bamboo Charcoal

The traditional method of burning bamboo charcoal adopted by people is brick kiln method, an old way of burning wood charcoal. On a well-chosen flat site, a carbonization chamber is dug to the depth corresponding to the selected kiln type and size. In front of the carbonization chamber, a combustion chamber is made of



bricks, whose front end is lower than the back end. The bamboo cubes or bamboo sticks should be made erect in the carbonization chamber while being loaded. Then the procedures of ignition, temperature raising, carbonization, kiln suffocating, cooling, unloading are followed. The bamboo charcoal made in brick kilns is unstable in quality and seldom meets high quality demand.

Since its properties for the environmental protection and healthcare have been unceasingly developed, the bamboo charcoal as well as its products receive more and more attention and the production keeps rising. For the sake of good quality, the production equipment and technology of bamboo charcoal has also improved a lot for many years of exploration and upgrading. Up to now, two types of equipment, pear-shaped brick kiln and mechanical furnace, are used and the according technologies are developed.

### 5.5.1 Kiln Structure

Figure 5.4 is the diagrammatic sketch of the structure of typical pear-shaped double kilns.

The top and side views of the double kilns are shown in Figure 5.4-a and Figure 5.4-b. The kiln is of 3.4 m in depth, 2.8 m in width and 2.5 to 2.7 m in height with 0.24 m-thick wall. The top of kilns is arched. The building process is as follows: First, 15 to 20 cm thick stones are levelly paved on the ground with a certain depth, followed by a layer of 20 cm thick yellow mud. Then another layer of bricks are laid on the top of mud. A layer of 20 cm thick yellow mud should also be laid on the kiln top, which serves to keep out the moisture and preserve the heat. The size of flue terminal is 100cm × 100cm. Figure 5.4-c is an explicit illustration of a kiln gate, which is 1.5 m high, 0.5 m wide at the bottom and 0.4 m wide on the top. There are five openings on the kiln gate. The openings A and B serves for adding firewood and observing flame and burning situation inside the kiln. C, D and E are air inlets, whose opening volume can be adjusted to control the air intake, thus controlling the increase rate of interior temperature.

This type of kiln has a capacity of four to six tons of bamboo and consumes two tons of fuel (firewood) in a cycle. Measures are taken to prevent the air pollution by smoke emitted in the process of charcoal making and to collect by-products. The specific procedures of a factory are as follows: Near the flue opening on the top of kiln, make two holes in a jar, one is square (10cm × 10cm) and the other is round. Next, build passageways with bricks to connect the square hole and the flue opening to let smoke go through. Then, take 4-5 bamboo culms with 7 - 8 m in length and remove the internal joint layers. Put one end of them into the jar, and fixate the other end in the air. Seal the jar opening with plastic films and earth. In this way, the smoke and vapor emitted from kiln go from jar through bamboo

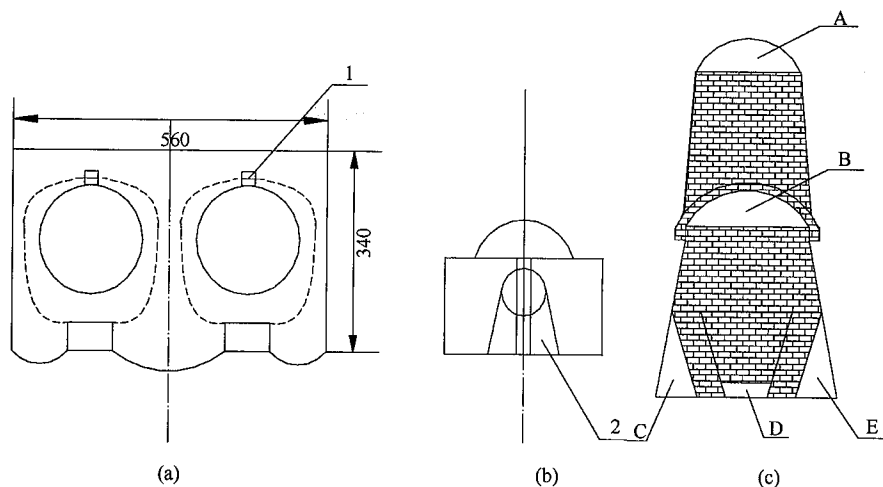

**Figure 5.4** Diagrammatic Sketch of the Structure of a Pear-shaped Double Kilns

(a) Planform (b) Front view (c) Side view

1. Flue 2. Side elevation, A, B feeding intakes C, D, E air intakes

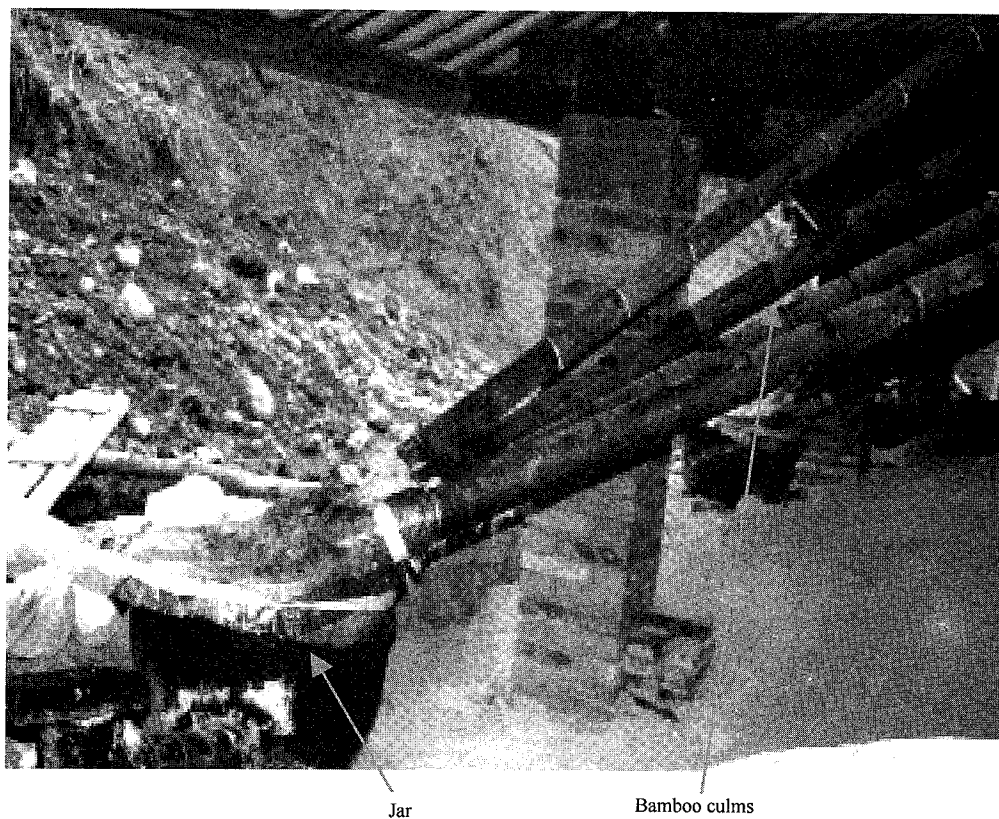
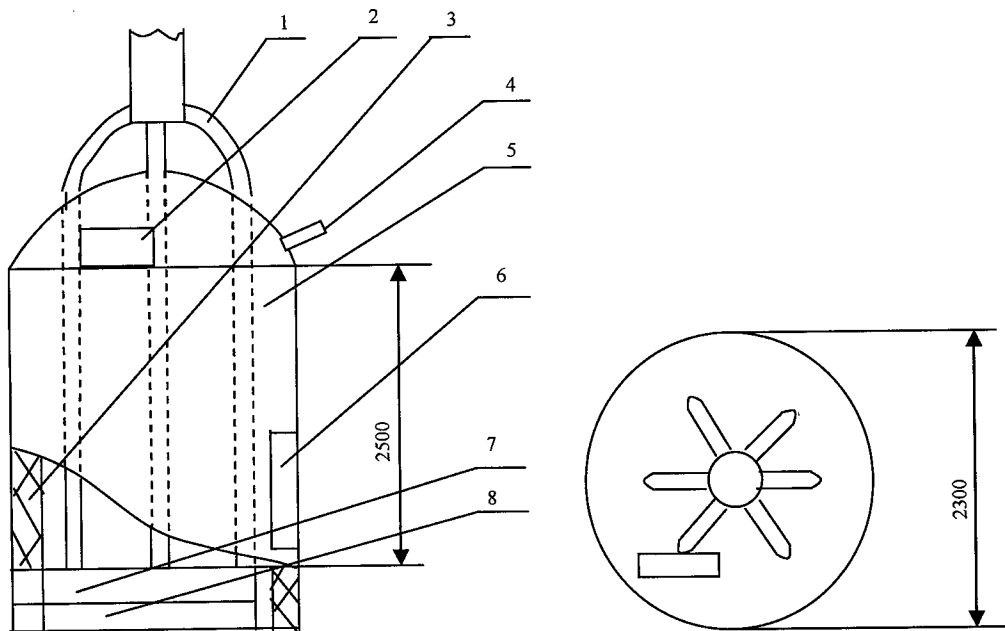

**Figure 5.5** The Instrument for Collecting Crude Vinegar on the Top of Kiln

culms, in which the smoke is condensed into condensate (raw bamboo vinegar) and flows back to jar. Connect a plastic pipe with round holds on jar body to draw out the raw bamboo vinegar. See Figure 5.4, 5.5.

### 5.5.2 The structure of Mechanical Furnace

A mechanical furnace is shown in Figure 5.6. It is 2.5 m high and 2.3 m in diameter. The round body is made of thin iron sheet lined with firebricks. There are two intakes on the body. One is fixed in the upper part and the other is lower that serves for raw material loading. There are 4 thermocouples in the furnace, two at the upper part and the other two at the bottom, for measuring the temperature at different points. So workers can adjust the combustion situation and master the product quality in accordance with the feedback temperature from the thermocouples. Furnace bars at the fuel feeding intake and inside the furnace are higher in the middle part and lower at side. Furnace is capable of burning both firewood and coal. Soot door is controlling the air intake and adjusting the flames.

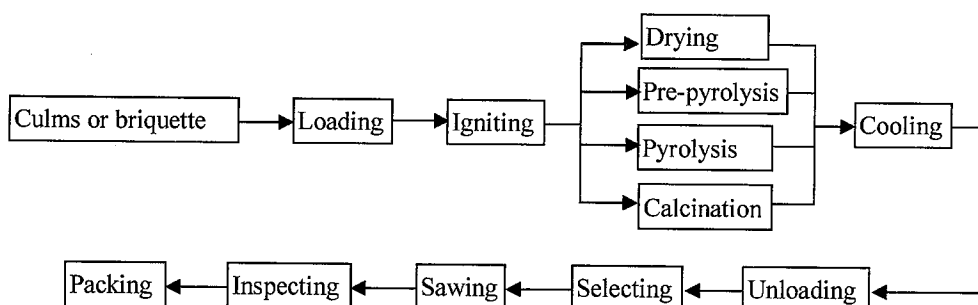

**Figure 5.6** Structure of a Mechanical Furnace

1. Flue 2. Top intake 3. Firebrick 4. Thermocouple 5. Body 6. Bottom intake
7. Fuel feeding opening 8. Soot door

### 5.5.3 Production Process

Here is the flow chart for the production of bamboo charcoal:



### 5.5.4 Requirement for Raw Material

#### 5.5.4.1 Raw material preparation for raw bamboo charcoal

Raw bamboo charcoal is made from bamboo culms, branches and roots. Raw bamboo charcoal products made from bamboo culm can be divided into bamboo tube charcoal, slice charcoal, particle charcoal according to the shape. Particle charcoal is smashed from tube charcoal and slice charcoal.

To improve the yields and quality of charcoal, the bamboo must be mature (over 4 years) without rot. Charcoal made from rot bamboos tends to be loose, fragile and spontaneously ignitable. The density, cavity structure and tissue composition of bamboo culms differentiate from bottom to top. So it is reasonable to divide the culms into three parts—the upper, the middle and the lower—for processing. There are abundant nutrient substances in bamboo material easily causing mildew and rot. Therefore the storage time of bamboo material should be strictly controlled, especially in summer. The newly cut bamboo culms should be cut and dried rapidly. Since the moisture content of culms highly affect the charcoal products, like the high rate of moisture content would definitely prolong the drying procedure in pyrolysis, increase the consumption of fuel, and decrease the productivity of kiln. If the drying speed is quicken, the moisture content of culms would fall dramatically to cause the cracking of culms and lower the quality of charcoal. Culms drying can be classified as natural drying and artificial drying. The small charcoal production enterprises favor natural drying, which piles up the culms on the buttress at raw material storage. The moisture content of raw bamboo should be 15% -20% before being loaded into kiln. Some factories burn the slice bamboo into charcoal, where the chopped tube is split into long slices.

#### 5.5.4.2 Raw material preparation for compressed briquette charcoal

The residues of bamboo processing are the major raw material for compressed bri-

quette charcoal. These residues include bamboo shaving, bamboo particle, saw powder, bamboo dust, and bamboo strips of different thickness and length. The raw material should be air dried before being processed, and the required moisture content would reduce the fuel consumption of drying. In addition, sand, rocks and such wastes should be removed from raw materials. The compressed briquette sticks would be made after a series of procedures, and then burned into charcoal in the furnace.

The flow chart of the bamboo briquette compressed sticks is demonstrated as Figure 5.7.

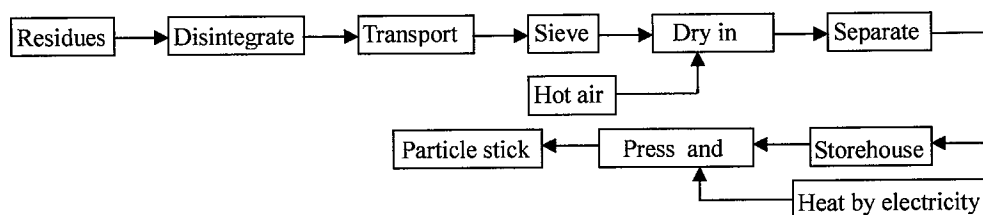

Figure 5.7 The Flow Chart of the Bamboo Briquette Compressed Sticks

The following are the main processing procedures for the bamboo briquette compressed sticks:

*a. Comminuting and sorting*

Send the residues to the disintegrator; after comminuting, convey them through strap transporter to the vibrant sifter for sorting; and the size of the bamboo fragments should be below 10 items. The qualified fragments will be conveyed by another strap transporter to the vertical pipe, and the fragments that are larger than 10 items will be sent back to the disintegrator to be recomminuted. And speed of the strap transporter is 50m/min, and the diameter of the roller is 0.7m.

*b. Drying*

The qualified fragments are sent to the vertical pipe by air-forced transportation devices; hot wind from the hot-wind furnace, with a temperature of 85°C, is input to the vertical pipe. The hot-wind mix together with the fragments in the vertical pipe, and heat up the fragments and evaporate the moisture. Then the air-forced transportation devices send the mixed airflow of the fragments and the hot wet air to the whirlwind separator; eject the separated hot wet air to the atmosphere, and the fragments after drying fall into the material storehouse. The moisture content of the fragments after drying should be within 4% - 6%.

*c. Molding by extrusion*

The bamboo fragments in the material storehouse fall into the helix-extrusion molding machine; and the molding machine is heated by electricity to 140 – 160°C; the fragments under this temperature will be easily molded; the fragments within the molding machine are extruded while being heated, after being extruded into the close-grained with the shape of club, they will be broken and extruded out of the outlet. Figure 5. 8, 5. 9 shows the figure of the bamboo briquette compressed sticks.

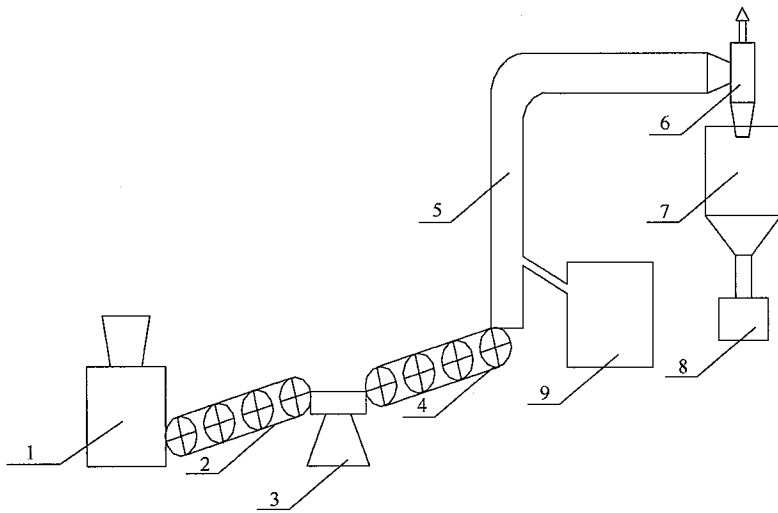
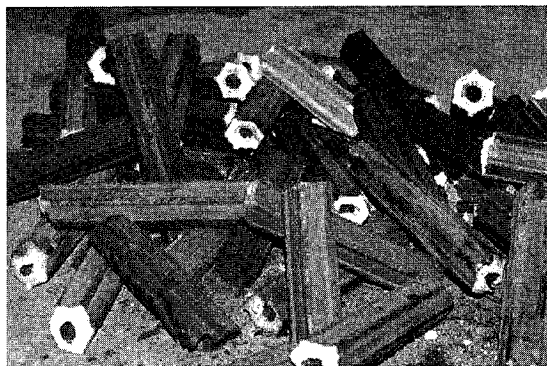

**Figure 5. 8** Diagrammatic Sketch of Bamboo Briquette Production Line  
 1. Disintegrator 2,4. Belt conveyor 3. Screen 5. Pipeline 6. Cyclone separator  
 7. Hopper 8. Particle forming machine 9. Heating furnace

### 5.5.5 The Instructions for the Main Procedures

#### 5.5.5.1 Kiln loading

Saw the bamboo tube (or cut into strips) according to the dimensions of the kiln, and the section of the bamboo briquette compressed sticks are cut regularly, then load the kiln by man power. The bamboo tubes (or strips) should be erected in the kiln, the bases upturned and the tips downward, and are arranged from inside to outside. The bamboo ma-



**Figure 5. 9** The Bamboo Briquette Compressed Sticks

terial at the outmost should be 0.5m from the kiln door, and the space left serves as a burning room for burning of the firewood. Finally, use the bricks and fire-resistant clay to block out the kiln door, leaving only the vaulted intake for adding the firewood and ignition.

#### **5.5.5.2 Ignition**

Firstly, put some flammable broken wood through the vaulted intake. Then put in the litten firewood and use the bricks and clay to block the most part of the intake, leaving a tiny ventage to examine the situation of the flame. The air enters from the air-entrance at the bottom of the kiln door. At the very beginning, open a ventage at the top of the kiln door so that the smoke can spurt out from the ventage. If the flow route of the smoke is short, it is easy for the firewood to get blazed. When the flame gets flourishing, block out the ventage at the top of the kiln door, so that the smoke can penetrate the bamboo timber and outflow from the flue at the back of the kiln.

#### **5.5.5.3 Warming (drying and the pre-carbonization phase)**

According to the burning situation of the firewood, open the kiln door at the certain time everyday to add more fuel so as to maintain the burning. Usually add the fuel two or three times each day, and then use the brick or clay to block out the vaulted intake. Modulate the burning situation through changing the size of the air-entrance at the bottom of the kiln door. In order to avoid adding fuel at midnight, block out the most part of the air-entrance to keep the mitigatory burning after adding the fuel in the afternoon, in spite of blocking out the intake. During this process, the temperature within the kiln should be increased gradually. If the temperature goes up too fast, it may cause the burst of the bamboo timber or the bamboo briquette compressed sticks. 7 – 8 days after the ignition, the temperature within the kiln should be kept below the firing point of the bamboo timber or the bamboo briquette compressed sticks. Then pay attention to the change of the temperature within the kiln, if it attains the firing point, reduce or stop adding the fuel.

#### **5.5.5.4 Carbonization and refining**

When the temperature within the kiln reaches 260°C, the bamboo timber will accelerate the pyrolysis so as to form large amount of resolvents, at the same time, emit huge amount of heat. When the temperature reaches 450°C, come into the refining phase. Then open the air-entrance of the kiln, add more fuel to accelerate its warming. During this process, do not open the kiln door completely within a short period of time; the time should be controlled within 24 hours so that the charcoal can contract sufficiently. After the refining phase, open the kiln door for 1 – 2 hours, so

as to increase the temperature within the kiln to 1,000°C or even higher. With the refinement, the redundant volatile substances in charcoal are ejected; and the fixed carbon content in charcoal enhanced. The calcinations phase is an important one determining the charcoal grade, which can be categorized according to the temperature (such as high temperature charcoal, low temperature charcoal, medium temperature charcoal).

During the practical operation, the charcoal farmers distinguish the pyrolysis phase according to the color and smell of the smoke from the chimney. In the drying phase, the color of the smoke is white, and as it contains lots of vapor, then the smoke smells acid; while when the carbonization begins, the smoke is yellowish, having a smell of tar; while the smoke is cyan, it indicates that the bamboo timber are completely carbonized and it can be refined.

#### 5.5.5.5 Sealing kiln for cooling and taking out of charcoal

After the refinement, use the brick and clay to block out the kiln door completely so that the charcoal in the kiln can cool down naturally. If the block is not complete, the charcoal in the kiln can be easily oxygenated and the charcoal output will be reduced. The duration for cooling is related to the temperature, and it usually takes about 5 – 6 days. When the temperature in the kiln goes down to 50°C, the charcoal can be taken out. While doing this, the kiln door can not be open completely immediately, but open a little. Only when the charcoal in the kiln does not reburn, can the kiln door open completely.

## 5.6 The Main Quality Index and Performance of Bamboo Charcoal

After the carbonization of the bamboo timber in different temperatures (300 – 1,000°C), the basic performances of the charcoal. Are examined and analyzed, which indicates that, with the different temperature in carbonization, the characters change drastically.

### 5.6.1 The Fixed Carbon Content

The fixed carbon content in charcoal is a presumptive conception, which is the charcoal content without ash when they are calcined without air under the temperature of 850 ± 20°C.

If the ash and the volatile substance content are known, then the fixed carbon content (%) in the charcoal can be calculated according to the following formula:

$$C = 100 - (A + V)$$

---



In the formula,  $C$ : the fixed carbon content in the charcoal (%);  $A$ : the ash content (%);  $V$ : the volatile substance content (%).

Because of the differences in final temperature while carbonization and the methods of pyrolysis, the fixed carbon content may range from 60% to 93% in the charcoal. With the increase of the temperature while carbonization, the relative content of the fixed carbon in the charcoal increases. Figure 5.10 shows that when the carbonization temperature is below 600°C, with the increase of the carbonization temperature, the relative content increases evidently, while it is above 600°C, the change of fixed carbon content is quite small.

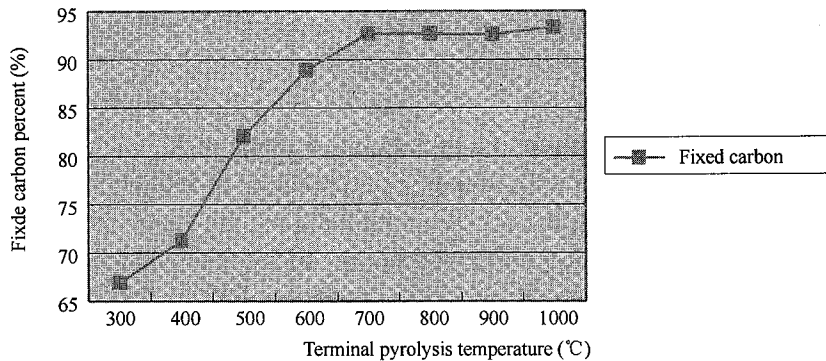

**Figure 5.10** The Relationship between the Fixed Carbon Content and the Final Carbonization Temperature

As to the charcoal calcined in medium temperature and high temperature, the fixed carbon content in the charcoal with the top quality should be more than or equal to 88%, with the second-class, its content more than or equal to 85%. For compressed charcoal stick, the first-class has a fixed carbon content of more than or equal to 86%, the second-class more than or equal to 82%.

### 5.6.2 The Volatile Substance Content in Bamboo Charcoal

Under the high temperature ( $850 \pm 20^\circ\text{C}$ ), the calcined charcoal may emit gaseous substances such as  $\text{CO}$ ,  $\text{CO}_2$ ,  $\text{H}_2$ ,  $\text{CH}_4$  and other hydrocarbon that are called volatile substance. The examination for the volatile substance can follow the American standards ASTM: D1762-84 (R2001) Standard Text Method for Chemical Analysis of Wood Charcoal K. The practical operation is to put the sample of charcoal after drying into the pot, and heat it up in electrical furnace with a high temperature of  $950^\circ\text{C}$  for 6 minutes, then put the sample into the desiccator to cool one hour and weigh. Calculate the volatile substance content according to the following formula:

$$\text{The volatile substance content (\%)} = [(B - C)/B] \times 100$$

In the formula,  $B$ : the sample weight (g) after drying in  $105^{\circ}\text{C}$ ;  $C$ : the sample weight (g) after drying in  $950^{\circ}\text{C}$ .

Figure 5.11 shows the relationship between the volatile substance content and pyrolysis temperature. And indicates that the volatile substance content will reduce with the increase of the carbonization temperature ( $30.38\% - 2.11\%$ ). Especially when it is below  $600^{\circ}\text{C}$ , the volatile substance content reduce drastically with the increase of the carbonization temperature. The reason is perhaps that the volatile substance content in charcoal is almost volatilized.

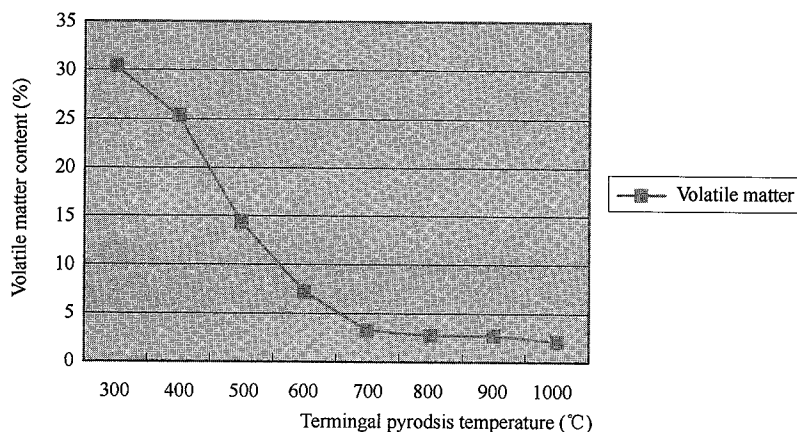

**Figure 5.11** The Relationship Between the Volatile Substance Content and the Final Carbonization Temperature

As to the charcoal calcined in medium and high temperature, the volatile substance content is less than or equal to  $8\%$ . In the final phase of charcoal calcining, the airproof of the equipments in the process of calcine and cooling greatly influences the volatile substance content because the charcoal absorbs lots of oxygen and creates lots of oxides while being heated. In addition, this process can go through with a low temperature of  $200 - 300^{\circ}\text{C}$ .

### 5.6.3 The Ash Content of Bamboo Charcoal

The ash content is the inorganic component in the charcoal, which will turn to white or pink substances after burning in high temperature. Figure 5.12 shows the relationship between the ash content and the final carbonization temperature. The components of ash elements in the charcoal is relatively complicated. The inorganic ingredients in the bamboo timber all remain in the ash, which are mainly silicon, potassium, sodium, calcium, magnesium, manganese and so on.

The examination for the ash can follow the American standards ASTM: D1762 - 84 (R2001) Standard Text Method for Chemical Analysis of Wood Char-

coal K.

The ash content will be calculated according to the following formula:

$$\text{The ash content (\%)} = (D/B) \times 100$$

In the formula, *B*: the sample weight (g) after drying in 105°C; *D*: the weight (g) of the residues in the pot.

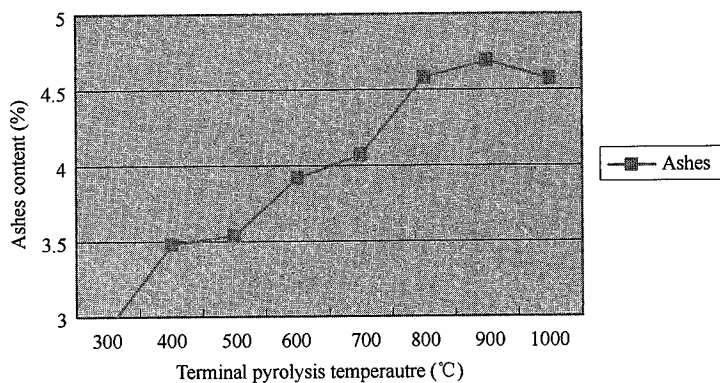

Figure 5.12 The Relationship between the Ash Content and the Final Carbonization Temperature

### 5.6.4 The Density of the Bamboo Charcoal

The density refers to the weight of the charcoal in unit volume.

Namely:  $P = m/V$

In the formula: *P*: the density of the charcoal (g/cm<sup>3</sup>); *m*: the weight of the charcoal (g); *V*: the volume of the charcoal (cm<sup>3</sup>).

As the charcoal contains lots of tiny holes, its density can be categorized into three types: filling density, grain density and real density. The grain density ( $P_p$ ) refers to the volume of the charcoal in unit volume, including the volume of the holes but not interspaces between the grains under certain circumstances. The real density ( $P_r$ ), also called the absolute density, refers to the volume of the charcoal in unit volume, not including the volume of the holes and interspaces between the grains, under certain circumstances. The most frequently used density is the filling density.

Filling density ( $P_B$ )

The filling density ( $P_B$ ) refers to the volume of the charcoal in unit volume, including the volume of the holes and interspaces between the grains, under certain circumstances.

Namely:

$$P_B = \frac{m}{V} = \frac{m}{V_g + V_h + V_r}$$

in the formular,  $P_B$ : filling density (g/cm<sup>3</sup>); *m*: weight of charcoal (g); *V*: vol-

ume of charcoal ( $\text{cm}^3$ );  $V_g$ : volume of interspaces between the grains ( $\text{cm}^3$ );  $V_h$ : volume of the holes in charcoal ( $\text{cm}^3$ );  $V_r$ : real volume of charcoal ( $\text{cm}^3$ ).

The filling density is measured usually by measuring cylinder. The charcoal density varies with the final pyrolysis temperature and the rate of temperature increase. Figure 5.13 shows the relationship between the filling density and the final pyrolysis temperature.

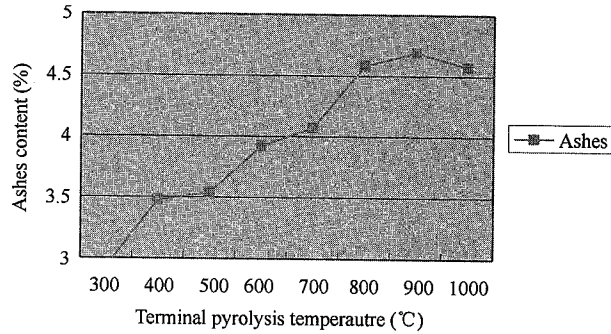

Figure 5.13 The Relationship Between the Filling Density and the Final Pyrolysis Temperature

### 5.6.5 The Electrical Property of Bamboo Charcoal

The conductivity of bamboo charcoal will increase with the increase of the carbonization temperature. And when the carbonization temperature reach  $700^\circ\text{C}$ , the conductivity of the bamboo charcoal is much better than that of wood charcoal because the ash content of bamboo charcoal is much higher than that of wood charcoal and the ash content contains many metal elements. The conductive differences of bamboo charcoal and wood charcoal are demonstrated in Figure 5.14.

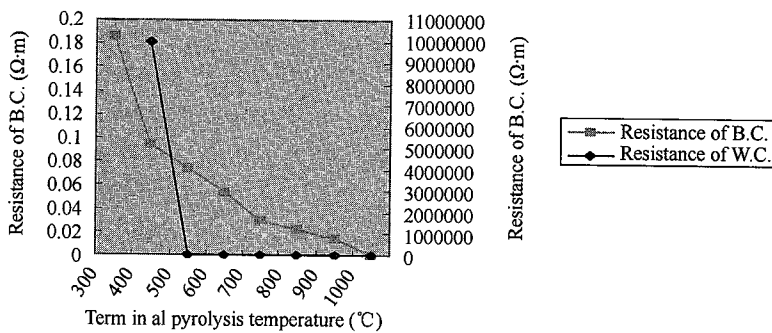

Figure 5.14 Relationships between Electric Resistance of Bamboo Charcoal and Terminal Pyrolysis Temperature

Figure 5.14 indicates that when the carbonization temperature is 700°C, the electrical resistance rate of bamboo charcoal is evidently reduced. And when the carbonization temperature is above 700°C, it reduces gradually. It is possible that the volatile substance content in the bamboo charcoal is almost resolved completely.

Different purposes may require different conductivities of charcoal. The high temperature charcoal is efficiently conductive, and can be used as electromagnetism shield material.

### 5.6.6 The Ratio Superficial Area of Bamboo Charcoal

The superficial area of one gram of solid bamboo charcoal is called the ratio superficial area. The ratio superficial area, the size and the distribution of the aperture are the important macro-structural parameters to describe the bamboo charcoal. It can reflect the reactive ability and the absorbing ability. Under the high temperature, the charcoal will form various holes, but they have a certain ratio superficial area. The superficial area is decided by the area within the holes (inner surface). The Figure 5.15 shows the relationship between the ratio superficial area and the final pyrolysis temperature.

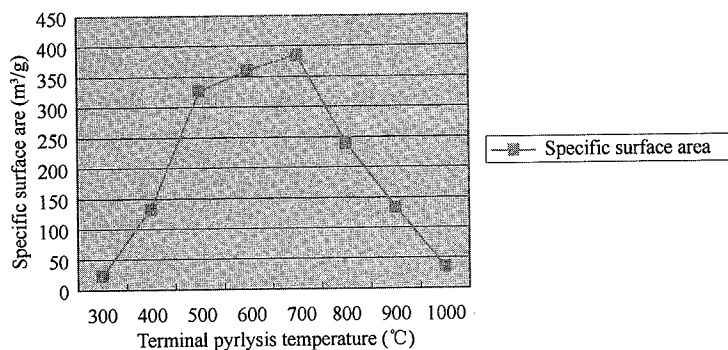

**Figure 5.15** the Relationship between Ratio Superficial Area and the Final Pyrolysis Temperature

It shows that when the carbonization temperature reaches 700°C, the ratio superficial area comes to the largest at 385 m<sup>2</sup>/g. And when the temperature is relatively low (< 500°C) as the carbonization is not complete, the holes are very small, so

the ratio superficial area is also low. When the temperature is relatively high (> 800°C), the holes are reducing or some holes lose the superficial area as they are burnt, thus the ratio superficial area is relatively low when the temperature is over 1,000°C.

There are many methods to test the ratio superficial area of the charcoal, and the most frequently used one is the BET volume method.

## 5.7 Factors Affecting the Pyrolysis Process of Bamboo

### 5.7.1 The Final Temperature of the Bamboo Pyrolysis

The output and composing of pyrolysis production is greatly affected by the final temperature of the bamboo carbonization. Experiments show that the output of charcoal reduces gradually with the increase of the carbonization temperature, and it reduces drastically within the range of below 400°C, and reduces gradually within the range of above 500°C. With the increase of the carbonization temperature during the bamboo carbonization, the production rate of charcoal decreases, while the fixed carbon content relatively increases; and the production rate of liquid and gaseous products also increases with the increase of the carbonization temperature.

The test for the ratio superficial area of the charcoal shows that when the carbonization temperature reaches 700°C, the ratio superficial area comes to the largest at 385 m<sup>2</sup>/g. Under the temperature of 700°C, the ratio superficial area increase with the increase of the carbonization temperature. And above 700°C, the ratio superficial area decreases. For the purpose of the production of bamboo active charcoal, the temperature should not be too high.

### 5.7.2 The Speed of Carbonization

The speed of bamboo carbonization affects the productivity of the carbonization equipments, so to accelerate the speed and shorten the time for carbonization can enhance the utilization rate of the carbonization equipments.

The carbonization speed is related to the factors such as the temperature rising rate, the size and the quality of bamboo timber, the methods of carbonization, the format of the carbonization equipments and so on.

Under rapid carbonization, the output of bamboo tar increases evidently, while the output of charcoal decreases because of the reduction of the bamboo quantity for the second-time reaction.

During the bamboo timber heat-emission reaction, a large amount of inner-produced gaseous substances come out of bamboo timber, causing the split and deformation of the charcoal and worsening the charcoal quality.

### 5.7.3 The Moisture Content of Bamboo Timber

The moisture content of bamboo timber directly affects the duration of pyrolysis and the consumption of the fuel. If the moisture content is too high, the carbonization process will take longer time, thus the fuel consumption is higher than the dry bamboo. In addition, if bamboo timber are dried in the carbonization kettle, it is much

easier to crack because of the unbalanced heat inside and the outside of it, therefore the quality of the charcoal gets degraded. At the same time, the concentration of the bamboo vinegar reduces and consume more energy in bamboo vinegar processing later.

Lower moisture content can accelerate the carbonization progress, but if bamboo timber is over dried, the heat-emission reaction could be too fierce, causing the degradation of charcoal quality.

Therefore, a certain content of moisture is required during the bamboo carbonization. Generally speaking, for bamboo carbonization in the outer-heat carbonization kettle, the suitable content of moisture should be between 15% to 20%.

#### 5.7.4 The Size of Bamboo Timber

Bamboo is not a good heat conductor, with a low heat conductivity of only  $1.0 - 1.4\text{J}/\text{m} \cdot \text{h} \cdot ^\circ\text{C}$ . With a large size of bamboo timber (long bamboo tube, big diameter, wide, thick and long bamboo strip etc.), the gradient of the moisture content of bamboo timber will increase at the beginning stage of temperature rising in the kiln (namely the drying phase in carbonization process), as the distance is far of heat-conducting to the center of bamboo timber and the heat-emitting route is also long. If the temperature in the kiln is sharply increased, it may cause the deformation and split of bamboo timber, degrading the quality of the charcoal; thus the temperature can only be increased gradually and the productivity of the kiln and furnace is reduced. Therefore, the size of bamboo timber should be determined reasonably according to the kiln, furnace and the size of the charcoal products.

### 5.8 The Application of the Bamboo Charcoal

As the bamboo charcoal has quantities of holes and large ratio superficial area, it has strong absorbing ability. At the same time, charcoal has stable physical and chemical properties. It does not dissolve in the water and other solvents. Except the reaction with oxygen in high temperature and with strong oxidants as ozone, chlorine and dichromate, it shows good stability in most practical circumstances. The charcoal can also be used in a wide range of pH value and in many solvents, as well as in the occasions of high pressure and high temperature.

#### 5.8.1 The Application of the Absorbing Ability

##### 5.8.1.1 Application to purify the indoor environment

###### *a. The main sources of the indoor air-pollution*

With the development of economy and the social progress, people take activities as

work, study and entertainment indoors more frequently. As the indoor environment is relatively close, the air quality is not satisfactory. The indoor air pollution sources could be indoor decoration, human body, the lampblack in the kitchen and so on.

**Indoor decoration.** As the living conditions have been improved, people put more and more money into the room renovation. Large amount of man-made floorboards, various kinds of granites have been entering the room. At the same time, they have also brought into the toxic substances as formaldehyde, ammonia, and benzene. If the decoration materials are bad in quality, the toxic substances may surpass the national safety standards in quantity.

Formaldehyde is a kind of blank, easily soluble, and pungent gas. The research shows that, when the content of formaldehyde indoor is  $0.1 \text{ mg/m}^3$ , people may feel the peculiar smell and uncomfortable;  $0.5 \text{ mg/m}^3$  may cause tearing;  $0.6 \text{ mg/m}^3$  make people sick, vomit, cough, oppressed feeling in the chest, pant or even emphysema;  $30 \text{ mg/m}^3$  may cause death. Long-term contact with formaldehyde of low dosage may cause chronic respiratory diseases, female diseases, physique degrade and, chromosome abnormality of the newborn baby, or even nasopharyngeal cancer. To control the formaldehyde pollution indoor, we can use the high-grade board materials with low-dissociating formaldehyde and keep ventilated in the room. Also, using the bamboo charcoal products with good absorbing ability is another good choice for the latent period of formaldehyde is very long and its releasing period can reach 3 – 15 years.

The main sources of ammonia is the cement antifreezer in the construction and the human body. Ammonia is bad for people's upper respiratory tract and eyes.

Benzene and same kind of substances mainly come from the paint used in room decoration and adhesive with wood veneer materials. They do great harm to the hemopoietic system of human body. The early symptoms could be the decrease of the leukocyte and the dizziness, fatigue and other diseases. Long time contact may cause cancer.

**Human body.** When people breathe, they take in air. The oxygen is absorbed in the pulmonary alveolus, and then people discharge the high-density carbon dioxide and some other toxic and harmful gas. The researches show that people discharge more than 20 kinds of toxic substances through exhaling, sweat and defecation as well as urination. Thus people always feel dizzy, difficult to breathe in the crowded room or room with bad ventilation. At the worst, people could feel oppressed in the chest or sick.

The smoke that smokers spit out is another main reason for the indoor air pollution. Under the high temperature, some of the components in the tobacco are broken down; some of them make the new chemical substances. While within the smoke, there are more than ten kinds of harmful substances as carbon monoxide, ammonia,



formaldehyde, callus, nicotine, tar and so on. These harmful substances do great harm to the organs of human body.

**The lampblack in the kitchen.** When the liquefied petroleum gases get burnt, it consumes the oxygen in the room, and emits carbon monoxide, carbon dioxide, oxynitride, aldehyde, benzene and hyrene. The vegetable oil we usually eat may form some kind of volatile substances as acraldehyde while being fried in high temperature. These harmful substances do great harm to human body.

*b. The prevention of the indoor air pollution*

To improve the indoor air quality, the main methods are focused on the following two: one is using the environment-friendly materials in the renovation, the other is making correct use of the purifying deodorizer.

The research shows that bamboo charcoal as well as other related products is a very good indoor purifying deodorizer. The bamboo charcoal is good at absorbing the harmful substances and can keep long-time absorption ability. It is renewable and can be used repeatedly. With property improvement, its absorbing ability can be better enhanced.

### **5.8.1.2 Application in water purifying**

Water pollution is a well known issue. Among the measures of environmental protection, it is an important one to purify the polluted water resources (underground water) and drinking water (ground water).

*a. Removing of 2,4-dichlorophenol by bamboo charcoal*

2,4-dichlorophenol is one of the main organic pollutants in drinking water. Researches show that bamboo charcoal is good at absorbing the 2,4-dichlorophenol.

**The experiment materials and methods.** Through grinding, diameter of the particle of the charcoal sample ranges from 0.06 mm to 0.9mm; 2,4-dichlorophenol; analyzing the purity; aether; analyzing the purity.

The experiment is carried out in three procedures:

a) The preparation of the standard solvent of dichlorophenol: correctly weigh 0.01g 2,4-dichlorophenol, using aether to resolve it in a bottle of 100mL. After making sure of the constant volume, shaking evenly, put them into the refrigerator for later use.

b) The experiment will use the static balance absorbing method: prepare a series of water solvent of 2,4-dichlorophenol with a certain concentrate, and put it into the triangle flask, correctly adding 0.02 – 1.00g bamboo charcoal, shake evenly. Then put it into the vibrator with constant temperature and keep static for a certain period of time, filter it and extract twice with the 25mL × 2 aether. And make

sure the constant volume is 50mL.

c) Test with gas chromatography: HP5890 Gas Chromatographer (Electron Capture Detector); HP-5 quartz capillary column (inner diameter 0.53mm, length 10m, thickness of liquid film); the temperature of the column 95°C, the temperature of the vaporizing room is 150°C, the temperature of testing room is 250°C, N230.5mL · min<sup>-1</sup>; the quantity of sample is 1 μL.

#### Experiment results and discussion.

a) The dynamics of bamboo charcoal absorbing reaction to 2, 4-dichlorophenol: Figure 5. 16 is the curve line for dynamics of bamboo charcoal absorbing reaction to 2,4-dichlorophenol. It shows that the absorbing ability of bamboo charcoal to 2, 4-dichlorophenol increases as the time goes. The absorbing speed is relatively fast at the beginning, and it turns to stable after 30 minutes, and then the speed turns slow. Model the relation between the absorbing quantity of bamboo charcoal to 2,4-dichlorophenol and the absorbing time, we can get the following equation:

$$\ln C = -0.896 - 0.00185t \quad (\text{coefficient } r = 0.863)$$

It shows that the absorption of bamboo charcoal to 2,4-dichlorophenol comply with the first-class reaction dynamics, it is mainly the function of Van Der Waals force among the elements.

b) The absorption isotherm: Figure 5. 17 is the experiment results about the effects of the concentrate of 2,4-dichlorophenol on volume of absorption.

Figure 5. 17 shows a good lineal relationship between the absorption quantity of the bamboo charcoal to 2, 4-dichlorophenol and the concentrate of 2,4-dichlorophenol (Table 5. 2).

c) The effects of the particle diameter: The particle diameter in the bamboo charcoal for the experiment is 0.06-0.90 mm, which are separated into 4 groups.

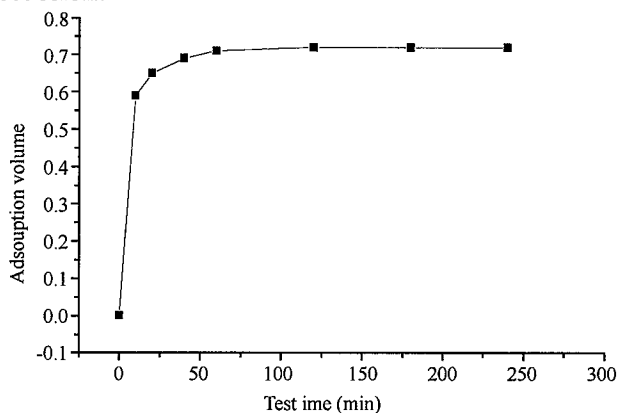

Figure 5.16 Effect of Treatment Time with Bamboo Charcoal on Adsorption Volume of 2,4-di-chloro Hydroxybenzene

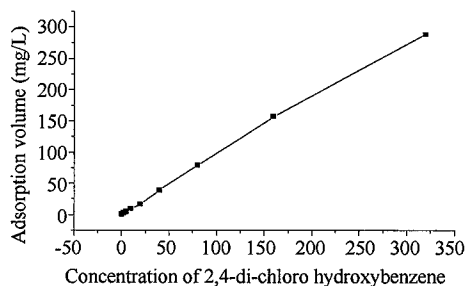

Figure 5.17 The Relation of Adsorption Volume and Concentration of 2,4-di-chloro Hydroxybenzene

The density of 2,4-dichlorophenol is 1 mg/L, pH is 6.4, the quantity of the bamboo charcoal is 0.2g, the experiment temperature is 20°C, the results are shown in Table 5.3.

**Table 5.2 The Removing Rate of the Bamboo Charcoal to 2,4-dichlorophenol in the Water**

The concentrate of 2,4-dichlorophenol (mg/L)	2.50	40	160	640
Concentrate after absorption (mg/L)	0.02	1.20	3.10	69.10
The removing rate	99.2	97	98.0	89.2

**Table 5.3 The Effects of the Particle Diameter of Bamboo Charcoal on Removing of 2,4-dichlorophenol**

Particle diameter	Diameter class	The absorption (mg/g)	The removing rate (%)
0.8-0.9	1	1.1	22
0.25-0.35	2	1.7	34
0.15-0.155	3	2.5	50
0.055-0.06	4	4.9	98

d) The effects of the pH: The experiment results about the effects of the acidity is shown in Figure 5.18. The bamboo charcoal shows a very strong absorption ability to 2,4-dichlorophenol when pH is between 2.0-10.0. And in this experimental conditions, the removing rate can get 99% or above.

e) Conclusion:

① The bamboo charcoal has a very strong absorption ability to 2,4-dichlorophenol, and its absorption reaction comply with the first-class reaction dynamics equation.

② In this experimental conditions, the largest absorption quantity to 2,4-dichlorophenol in the water can get 1,500mg/g.

③ The absorption ability of the bamboo charcoal to 2,4-dichlorophenol is related to the particle diameter of the bamboo charcoal, the ratio superficial area and the absorption temperature and so on.

④ The bamboo charcoal shows a very good absorption ability to 2,4-dichlorophenol When the pH is 2.0-10.0.

#### *b. Application in cooking and water boiling*

Bamboo charcoal is rich in natural mineral elements as potassium, magnesium, sodium and calcium, besides the function as removing the residual chlorine, chloroform and other harmful substances. The experiment shows that after the bamboo

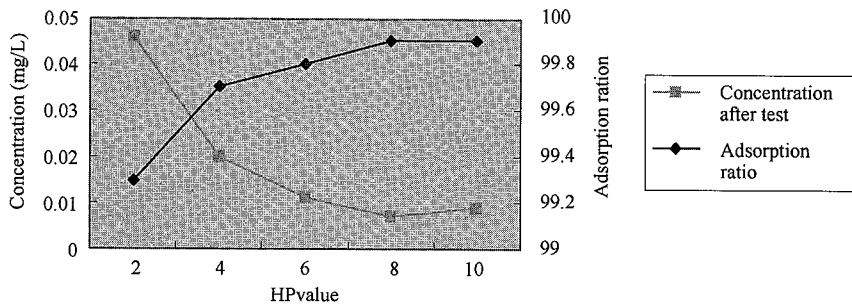

Figure 5.18 Effect of Acid Value on Adsorption Ratio of Bamboo Charcoal

charcoal is put in the water for a while, the metal ion in the water will be resolved out. Therefore while cooking and boiling water, putting in some bamboo charcoal can improve the quality of the water, add the microelements, and make the water tasty. And the water will be very good for health. See Table 5.4.

Table 5.4 The Experiment Results of the Metal Ion Resolving from Bamboo Charcoal (mg/L)

Item	K	Na	Al	Ng	Ca
The first time resolving of the charcoal	11.4	0.84	0.032	0.079	0.5
The second time resolving of the charcoal	6.1	0.82	0.02	0.055	0.37
The third time resolving of the charcoal	5.6	0.78	0.02	0.053	0.2

c. Application in moisture adjusting

Since the calcine process of bamboo charcoal is completed under high temperature and oxygen absent, the charcoal almost has no moisture. With lots of tiny holes, charcoal can absorb the moisture 1% – 4% of its own weight. Thus it is quite effective in adjusting the moisture. When the humidity in the environment is higher than that in charcoal, it can absorb large amount of moisture; when the humidity in the environment decreases, it can emit moisture so as to keep the balance. In this way, bamboo charcoal adjusts the humidity in the environment. The bamboo charcoal could be put under the floor or behind the wallboard of the room so that it can be concealed from sight and at the same time achieve the functions of moisture adjusting.

5.8.2 Application of the far Infrared Rays Ability

Bamboo charcoal has the ability to radiate the far infrared rays. Using it to massage and touch the human body, it is good for the blood circulation. Put into the oil, bamboo charcoal can help to fry the delicious food and the oil will not be oxidized. Put into the bathing pool, the charcoal radiates the far infrared rays and the wave length turns shorter, and absorbs more heat. The human body absorbs the far infrared rays from the charcoal which turn to the heat energy and congregate within the body.

### 5.8.3 Application in Deodorization and Keeping Fresh

The refrigerator is the place that people preserve the fresh food, as well as the most frequently used electrical appliances at home. However, as the refrigerator is large in content, the raw, the cooked, vegetables, fruits, fresh fish, meat are all put into it. Although the designers of the refrigerator are quite considerate to separate the room and case for storage, the various of smell could mix together and make the refrigerator full of various smells due to the ventilation design for achieving the best effects of cooling, storage and freezing. The charcoal and its improved products can better remove the peculiar smell in the refrigerator. If we wear a pair of shoes for a long time, they may be filled with smelly smell of sweat, the using of the charcoal insole and plug can remove the smelly smell of the shoes. In addition, bamboo charcoal can adjust the moisture, so as to prolong the fresh period of the vegetables and fruits. After a period of using, we can take out the bamboo charcoal and wash it up, reuse it after burnt in the sunshine.

### 5.8.4 Application of Other Properties

#### 5.8.4.1 Bamboo-based active carbon manufacturing by activation of bamboo charcoal

As a good absorbent, active carbon can be used in the fields as food, medicine, chemical industry, environmental protection, military for decoloring and purifying. Its market is increasing gradually, but timber logging is restricted strictly which produce one of the raw materials for active carbon. Thus the development of the new materials for active carbon becomes a very important subject. Bamboo grows fast and spread in a wide range of area. And most of the properties of bamboo charcoal are similar to the wood charcoal (please see Chapter 6 the property of the bamboo charcoal), proven by the analysis. Therefore, bamboo charcoal can produce bamboo-based active carbon through further activation. The good quality active carbon was produced in lab experiment, using the carbonization materials at the temperature of 500°C, and putting in vapor as the activator in the high temperature of 900°C. The main absorption properties is as follows: the iodine-absorption value is 1,000mg/g, the methylene blue-absorption value is 180mg/L, and the output rate is 30%.

#### 5.8.4.2 Electric properties of bamboo charcoal and its application

The electric properties of the bamboo charcoal are varies with carbonization temperature. The resistivity of the bamboo charcoal is quite low under the carbonization temperature of 700°C ( $< 5.4 \times 10^{-5} \Omega \cdot m$ ), showing a good conductivity. At the same time, the high temperature bamboo charcoal (1,000°C) has the function of electromagnetic wave shielding. The electric properties of bamboo charcoal and its relationship with factors as carbonization temperature, hole structure, the degree of graphitization still needs further research.

# *PART 2*

## **BAMBOO SHOOT PROCESSING AND UTILIZATION**

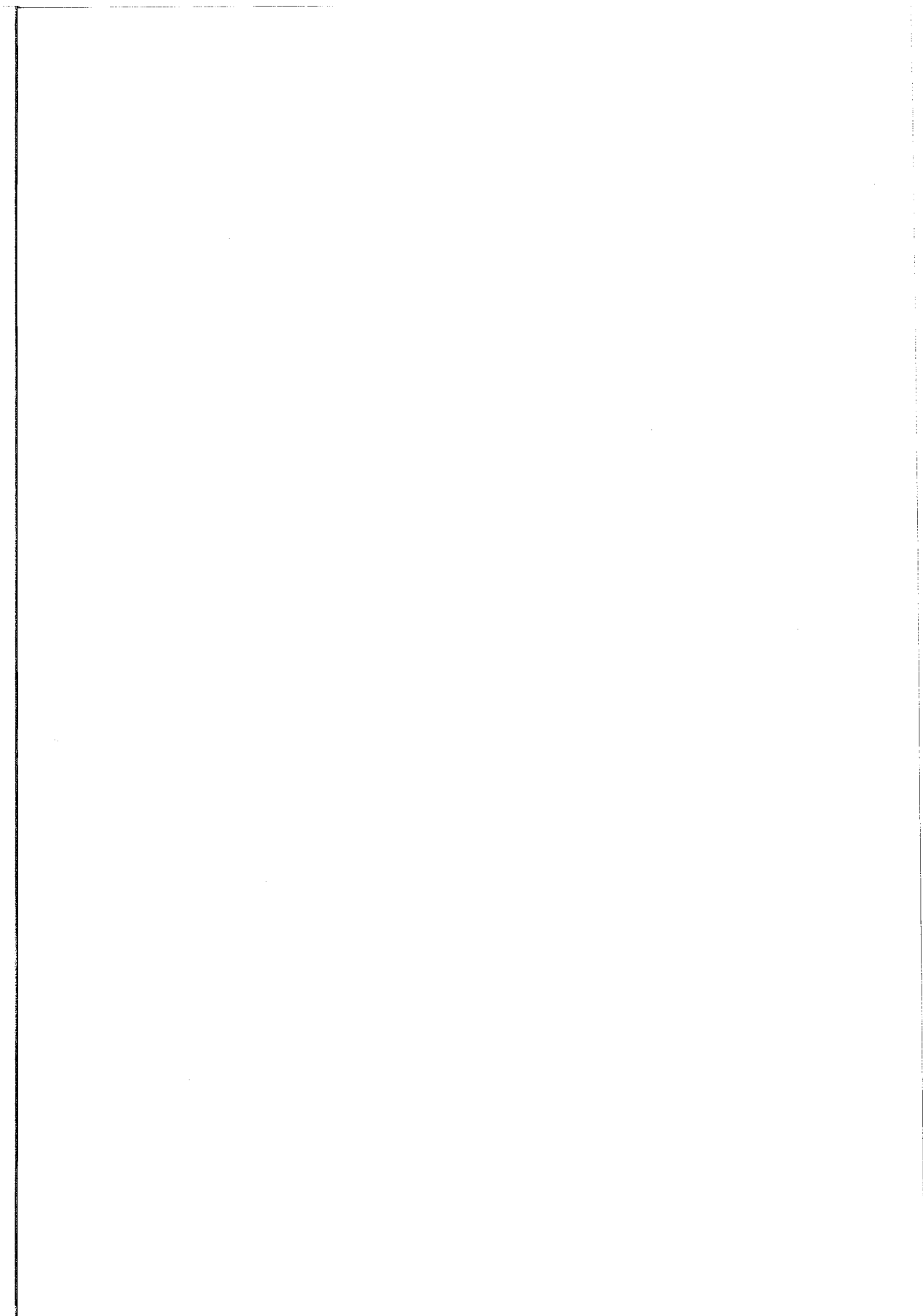

# CHAPTER 6

## Utilization of Bamboo Shoots

### 6.1 Introduction

Bamboo, with big economic and ecological importance, is one of the fastest growing, most versatile, and annually renewable and harvestable plants with highest productivity and short harvesting cycle. For a long time, bamboo has been highly honored for its multi-use timber, edible shoots as well as special cultural value. At present, the total area of bamboo forest in the world amounts to 20 million ha and is rising continuously, while global forests are shrinking in area. Therefore many countries have begun to encourage investment in bamboo resources which will result in considerable economic benefits and solve many ecological problems.

With reference to the producing area and edible history of bamboo shoots, China ranks first in the world. Since almost Zhou Dynasty, bamboo shoots have already become the delicacies on the table. Due to various species and different growth seasons of bamboos, it is known that in China nowadays there are 39 genera of bamboo shoots with around 500 species, distributing in Zhejiang, Fujian and Jiangxi Provinces. According to different seasons, edible shoots include mainly three types: winter shoots, spring shoots and rhizome shoots which are made into products such as boiled shoots and dried shoots convenient for storage. With a good reputation both in domestic and international market, Chinese bamboo shoots industry has developed quickly with a good sale in Japan and Southeast Asia.

With the deepening of economic restructuring, the implementation of the national macroscopic controlling policy, and the turbulence of economy in the international world, the processed products of shoots have made an appearance of sluggish market, loss of yield and benefit-slide, which will affect the development of bamboo resources moreover. Along with China's accession to WTO at the beginning of the new century, Chinese shoot industry will enter a novel historic era confronted with more challenges and also opportunities.

---



The utilization of bamboo has a long history in China. The expression, "rarity food" has been used to eulogize bamboo shoots in ancient times. Edible shoot was praised as "rarity in vegetables" by Li Liweng, a literati of Qing Dynasty. He believed even pork or mutton was not to be compared with it. Poets and literati in all ages have written various odes to resound it. Shoots are famous for various delicious dishes in the four major cuisines of China, cooked both as main course and ingredient. It is taken as a healthy food rich in nutrition, which contains about 16 kinds of amino acids. In addition, there are carotene, vitamin C, Ca and other mineral substances in shoots.

## 6.2 Nutritive Value

Bamboo shoot contains kinds of nutritive substances that human body needs, such as carbohydrate, protein, fat, fiber and many other inorganic nutritious substances, and Vitamin A, B, C as well. Shoot is very nutritious natural food. Fresh shoot generally contains 88% - 93% water, 1.5% - 4% protein, 0.25% - 0.95% fat, 0.78% - 5.86% total sugar of which 0.44% - 2.95% soluble sugar, 0.60% - 1.345% cellulose. 0.66% - 1.21% ash, 37 - 92 mg · kg<sup>-1</sup> phosphor and 4.2 - 30 mg · kg<sup>-1</sup> calcium are also contained (see Table 6.1).

Shoot is delicious and nutritious. It can be cooked by parching, stewing, braising, boiling, curing, and cooked with vegetable and meat as well. Shoot, non-pollutant, also can be preserved in cans.

**Table 6.1 Comparison of Nutrient Contents of Several Vegetables**  
(edible parts per 100 gram)

Vegetable	Protein (g)	Fat (g)	Carbohydrate (g)	Calcium (g)	Phosphor (g)	Ferro (g)
Moso bamboo shoot	2.6	0.2	7	10	76	0.5
Radish	0.6	0	6	49	34	0.5
Chinese Cabbage	1.1	0.1	2	86	27	1.2
Cabbageg	1.3	0.3	4	62	28	0.7
Lotus Root	1.0	0.1	20	19	51	0.5
Lettuce	0.6	0.1	2	7	31	2.0

## 6.3 Hygienic and Pharmaceutical Value

Shoot has a certain extent of hygienic and pharmaceutical value. Doctors of traditional Chinese medicine believe that shoot is cool in nature and sweet in flavor. It

can well function as diuretic and it can also reduce thirsty, clear lung-heat and dissolve phlegm. Some effective treatments on dropsy, ascites, acute nephritis, asthma and diabetes can be carried out by taking shoots. Many pharmacological testing have proved shoot is beneficial to human health. It has the functions of anti-neoplasm, anti-aging and it can eliminate free radical. Therefore, shoot can be taken as one of important food treatments.

Cooked with meat, shoot can nourish body's essential fluid and improve blood quality by Chinese conventional acknowledgements. Fired and boiled shoots can promote digestion and clear away phlegm, and also perform well in head disease therapy. However, one with stomach diseases must be cautious and eat less. Kinds of vitamins can be found in shoot. Recent researches have proved that cellulose and hemi-cellulose in shoots can promote bowel squirming and digestion glandular secretion. They can thus help human bodies digest and excrete so that entrapment and absorbing of harmful substances in human bodies can be diminished. Rate of intoxication and bowel cancer can be reduced and fat deposition can be reduced too. Shoot is thereby called "the first vegetable" in China. The researches have also discovered the mixing of cellulose in shoot with fatty acid in human bodies can prevent the forming of cholesterol in human blood so that some extent of treatment on blood diseases can be well performed as well. Tyrosine in shoot can effectively inhibit the spreading of cancer cells. Shoot also contains the microelements which are cancer-resistant such as Se and Ge.

## 6.4 Types of Bamboo Shoots

### 6.4.1 By the Growing Season and Position

Shoot types vary much. By different growing seasons, it can be classified into winter, spring and rhizome. Winter shoot, white, delicate and delicious, is the underground delicate shoot of moso bamboo in winter. Rhizome, white, crisp, mildly bitter but fresh, is the delicate twig of shoot grown in the soil in summer. While Spring shoots are the most important raw materials for processing, the quantity of which can be over 80% of the total shoot yield in a year. Shoot has always been cherished as "the pearl in dishes" in China.

### 6.4.2 By Size

According to different sizes, shoots can be classified into large-size sympodial shoots, medium-sized sympodial shoots, large-size monopodial shoots, medium-sized monopodial shoots, small-sized shoots and sundry shoots. *Phyllostachys dulcis* McClure shoot and *Dedrocalamopsis Latiflorus* Munro shoot etc. are edible large-

size sympodial shoots. Generally, *Dendrocalamus* Nees, *Gigantochloa* Kurz ex Munro and *Thyrsostachys* Gamble all belong to large-size sympodial bamboo. Large-size monopodial shoots include *Phyllostachys heterocyclapubescens* (Mazel) Ohwi shoot and so on. Medium-sized monopodial shoots include *Sinocalaincis oldhami* shoot, *Sinocalamus minor* McCl shoot, *Dendrocalamus membranaceus* Munro shoot, *Sinobambusa edulis* Wen shoot, *Bambusa cerosissima* McClure shoot etc. Medium-sized monopodial shoots include *Phyllostachys bambusoides* Sieb. et Zucc. shoot, *Phyllostachys rirdescens* Yao et Chen shoot, *Phyllostachys praecox* Chu et Chao shoot, *Phyllostachys bambusoides* Sieb. et Zucc. shoot etc. There are also small-sized shoots such as *Pleioblastus amarus* (Keng) Keng f. shoot, *Leptocanna chinensis* (Rendle) Chia et H. L. Fung shoot, *Phyllostachys nuda* McClure shoot, *Chimonobambusa quadrangularis* (Fenzi) Makino shoot, *Ferrocalamus* Hsueh et Keng f. shoot, *Phyllostachys puberula* (Miq.) Munro shoot etc.

#### 6.4.3 By the Delicious Flavor Feature

In terms of delicious flavor feature, shoot can be classified into sweet shoot, bitter shoot, fragrant shoot and slight flavor shoot.

#### 6.4.4 By the Processing Type

Classified into fresh, preserved, canned, seasoned and dried shoot.

### 6.5 The Introduction of Several Frequently Eaten Bamboo Shoots

#### 6.5.1 *Phyllostachys heterocycla* var. *pubescens* (Mazel) Ohwi (Moso Bamboo) Shoot

Moso bamboo is also called as *Phyllostachys pubescens* Mazel ex H. de Lehaie or *Semiarundinaria farinosa* McClure. Its major features include fast growing, high productivity and multiple uses. It spreads the widest in China and produces great profits. Its shoot is an important traditional vegetable, containing many kinds of amino acid, mineral elements, cellulose and other microelements. It is considered as natural health food and popular with domestic and foreign consumers. Many places have begun to grow moso bamboo forest actively and productively. Moso bamboo is a kind of superior monopodial bamboo species with edible shoots. It spreads wide, grows fast with long shooting period and high yield. Moso bamboo shoot

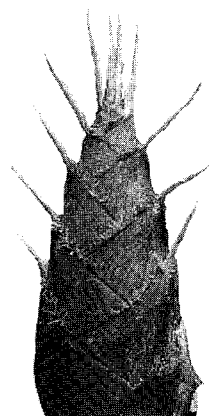

owns large proportion in all kinds of shoots. In fall, the buds on moso bamboo branches begin to differentiate and puff. From October to next February, the shoots in the soil are called winter shoot. In some places, spring shoots still in the soil in mid – March are called “Tan” shoot, and shoots come out from April to May are called spring shoot or “Mao” shoot. The delicate part of moso bamboo rhizomes from June to September is called “Bian” shoot, during which shoots in July, the raining season, are called “Mei” shoot and “Bian” shoots in August are called “Fu Bian”. Consequently, moso bamboo shoots can be dug out in four seasons and they can be eaten directly or processed into canned shoot, sliced shoot, dried shoot and so on. Generally speaking, winter shoots taste more delicious than spring shoots.

### 6.5.2 *Dendrocalamopsis oldhami* Shoot

*Dendrocalamopsis oldhami* is a kind of sympodial bamboos of good adaptability. It grows mainly in tropical and subtropical monsoon areas such as Fujian, Taiwan, Zhejiang, Guangdong and Guangxi. Its culm is about 6 – 9 m in height and 5 – 8 cm in diameter. It has no obvious underground rhizome and it is sympodial.

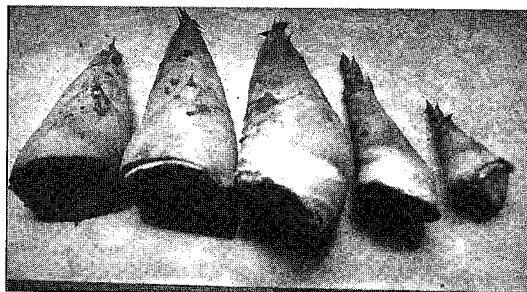

It grows and produces shoots in summer and fall. Its shoots can be eaten fresh or canned to export for their crisp and delicious features. The shooting period is from May to October. June is incipience. July and August are major onset which can be extended to November if mild enough. Shoots can be produced in three years after planting. Major onset can be achieved if managed properly. Under



normal condition, it can produce 7,000 – 15,000kg shoots per hectare, 15 – 30kg per clump. Economic benefit is considerable since the input and output rate is 1:12.

### 6.5.3 *Dedrocalamus latiflorus* Munro Shoot

*Dedrocalamus latiflorus* Munro is also named June or August Bamboo. Sympodial *Dedrocalamus latiflorus* Munro mainly grows in Guangdong, Guangxi, Guizhou, Taiwan and South Hunan. It generally grows on the plain, the hillside or the river-

side. The shooting period is from July to October. It is fine breed of bamboo for its shoots' sweet and delicious taste and great productivity. Its extra names are *Phyllostachys dulcis* McClure and *Sinocalamus latiflorus* (Munro) McClure. It belongs to large-size sympodial bamboos. Culms are high and strong, with 50cm internodes. The average height is 20m. Some are over 30m. Grown bamboos have 20cm diameter, some over 33cm. It is thus one of the highest giant bamboos in China. The shooting period lasts from May to October. The average weight of its single fresh shoot is 4 – 5kg, some even over 20kg. Besides the shoots' marvelous sizes, they also have very high productivity. If 222 culms are planted in 1 mu (about 667m<sup>2</sup>) land, 600 – 1,000kg fresh shoots can be produced the current year, 2,000 – 3,000kg next year. In the third year, which comes to the major onset year, averagely 5,000 – 8,000kg can be harvested, with the highest reaching 16,000kg per mu (1mu = 1/15ha). It is therefore the breed of the greatest bamboo shoot productivity in China. The major features of its shoots are delicate, crisp and sweet. So it is also one of the breeds which have shoots of the best quality. Statistics show that



its shoot contains 21.65% – 31.28% protein, 0.149% fat, 2.15% total sugar, 0.168% raw fiber. It also contains elements such as phosphorus, magnesium, calcium, ferrum and vitamin B<sub>1</sub>, B<sub>2</sub> and C and 17 breeds of amino acid as well.

#### 6.5.4 *Pleioblastusamarus* Shoot

China is one of the origins of *Pleioblastusamarus*. Major features of its shoot are fresh, crisp and delicious. It can reduce thirsty and clear away heat. It contains rich vitamins and amino acid. It tastes mildly bitter and cool. Coughing, bronchitis and sweating after bearing can be well treated with it.



#### 6.5.5 *Phyllostachys praecox* Chu et Chao Shoot

*Phyllostachys praecox* Chu et Chao is also called as *Phyllostachys praecox* f. *prevernalis*. It belongs to *Phyllostachys* Sieb. et Zucc. Its shooting period is 20 – 25 days earlier than *Phyllostachys heterocyclus pubescens* (Mazel) Ohwi and the period last 40 – 50days. Generally, shoots begin to unearthing before the Spring Festival or in early March till the end of April. October to December can be the unearthing-period as well. Its shoots can be marketed

during the Spring Festival if the bamboo garden where they grow is well covered and managed. It is the major season dishes in Zhejiang and Shanghai in early spring for its freshness and deliciousness. The shoot productivity is high with 3,000kg shoots per mu. The shoots are nutritious, containing 2.7% protein, 0.52% fat and 3.54% total sugar.

---

# CHAPTER 7

## Bamboo Shoot Food

Canned shoot can be classified by forms into whole shoot, shoot tip, shoot strip, shoot slice, diced shoot, shoot lump, shoot wing and shoot cover.

### ① Whole Shoot



Decorticate and clean the newly dug out shoot. Then cut the old tough node from the bottom.

### ② Shoot Tip

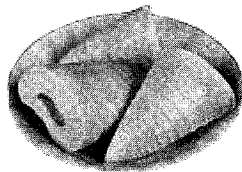

The most delicate part on the top of the shoot, i. e. the top 1/3 of the whole shoot.

### ③ Shoot Strip

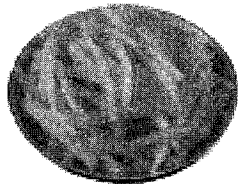

Cut the shoot head, remove the cover and cut it into strips. Dry them after being boiled in water. The final product is golden and can be preserved for long time. Soak them in hot water for 1 hour to 2 before simple parching or soy steaming. The fresh and sweet taste makes it very popular among dishes.

④ Diced Shoot

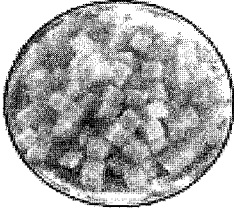

Cut the shoot head, remove the cover, clean it and cut it into dices. Boil it and then dry it to complete.

⑤ Shoot Wing

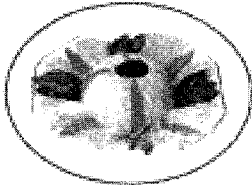

First boil the tip about 2 minutes and refrigerate by cold water. Trickle to dry and cut to slices from tip to bottom.

⑥ Shoot Cover

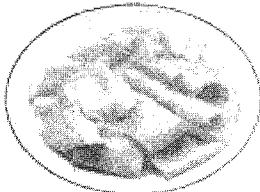

Shoot cover is the soft part beneath the shell. Remove, steam and dry the cover when making canned shoot. Shoot cover is best used to cook soup. Fry or stew it with meat is good as well.

⑦ Shoot Lump



Remove the shell of fresh winter shoot, clean it and then put it into cold water. Cut it into lumps after boiling it.

Series of retort pouch products are as follows :

### 7.1 Vegetables (in Need of Cooking Again)

1. whole shoot in water
2. shoot lump in water
3. shoot slice in water
4. shoot strip in water
5. diced shoot in water
6. whole shoot in brine
7. shoot lump in brine
8. shoot slice in brine
9. shoot strip in brine
10. diced shoot in brine etc.



## 7.2 Dishes (in Need of Heating with the Package or Eating Directly after Opening the Package without Heating It)

1. braised shoots
2. stir-fried shoots with mushrooms
3. shrimps with fresh shoots
4. preserved shoots and peanuts
5. preserved shoots and beans
6. pickled cabbage with shredded shoots
7. shoots, mushrooms and peanuts
8. shoots, mushrooms, and beans
9. dry baking fresh shoots
10. stewed fresh mushrooms with shoots
11. fried fresh shoots
12. braised fresh shoots
13. stir-fried shoots with meat
14. fresh pork and salted pork with shoot soup
15. shoots with paste
16. wine preserved shoots
17. stir-fried basketry shoots
18. fumigated shoot
19. multi-flavor preserved shoots and peanuts
20. spicy and sour shoots
21. stir-fried pork and shoot shreds with chili sauce etc.

## 7.3 Snacks (in no Need of Cooking, having Them as Snacks Alone or Having Them When Drinking)

1. spicy and sour shoot slices (strips, dices, lumps)
2. multi-flavor shoot slices (strips, dices, lumps)
3. dried shoot slices with paste (strips, dices, lumps)
4. sweat and sour shoot slices (strips, dices, lumps)
5. shoots and preserved plums etc.

## 7.4 Side Dishes

There are a wide variety of side dishes. They can be utilized with most of deep processing products, such as with chicken, fish, meat, rice or dumplings.

# CHAPTER 8

## Preserving Techniques

Besides being freshly cooked and eaten, bamboo shoot can be processed into cans or various flavoring shoots. Preserving problems, as followings, are often encountered in utilizing and processing them.

(1) Producing period cannot last long. No enough time to process in major on-set season and no material supply in off-season. Shoots must be preserved to solve the problems happening in storing and transporting.

(2) High-grade shoot (sweet shoot) must be preserved to maintain the original flavor.

(3) Some breeds are in good flavor after boiling but lose flavor after canning. Preserving technology is essential.

Rhizome shoot will be spoiled after one-week-storage. Spring shoot will be spoiled after half day and so will winter shoot after one-month storage. Nutrition analysis by seven approaches has shown that River Sand Approach preserve the shoot in longest fresh condition to more than four months. Plastics Bags Approach, Soil Pit Approach (35cm deep pit with cover) and Put-in-Jar Approach can preserve shoot to two months and maintain the fresh quality. Refrigerator Approach preserve to 3 months below  $-10^{\circ}\text{C}$  (with the flesh softened). However, shoots will be spoiled after one month if Put-on-the-Floor Approach is applied. After four-month storage, the moisture-diminishing rates respectively are 11.1%, 9%, 23%, 26%, 48% and 80%.

Therefore, River Sand Approach, Plastics Bags Approach, Soil Pit Approach and Put-in-Jar Approach are the best preserving approaches. Refrigerator and vine basket is for temporary preserving.

Different places in China have developed preserving liquor and preserving additive. They preserve the fresh shoot in processing and storing. Fresh shoots are preserved by utilizing chemical and antiseptic technology. Shoots packed in plastic bags and cans can be preserved from eight months to one year. Preserving technology in Research Institute of Subtropical Forestry, Chinese Academy of Forestry and

---

Anji County of Zhejiang is advanced in China and has positive perspective globally.

## 8.1 Features Which May Influence the Preserving

Systematic studies have summarized the features which may influence the preserving as follows:

### 8.1.1 Shoot-growing Quality of Bamboo

Among 500 breeds of shoots, most of them are edible, such as moso bamboo in center subtropical areas and *Dendrocalamus latiflorus* in south subtropical areas. The shoots-growing periods are in four seasons. The shoot-growing quality will influence much on preserving.

### 8.1.2 Physiological Activity

Shoot is the edible bud of bamboo. Being the most active organ in plants, it requires much in preserving. After being harvested, respiration intensity of shoots with shell is 47.38 CO<sub>2</sub> mg/(kg · h) in 2 hours. Rise to 277.84 CO<sub>2</sub> mg/(kg · h) after five hours. Respiration intensity of no-shell-shoots is 399.96 CO<sub>2</sub> mg/(kg · h) and reaches 1,178.08 CO<sub>2</sub> mg/(kg · h) in five hours. Rotten part can be found from the appearance. Moisture diminishing rate reaches 20% in two weeks below 10 – 15°C. *Dendrocalamus latiflorus* in south subtropical areas diminish water faster in the summer growing season.

### 8.1.3 Planting and Harvesting Quality

Shoot usually has extensive management which makes preservation have special features. (1) Big wound area causes severe wound respiration; (2) Self-fiberization degrees are different; (3) Different in size; (4) Collected and bought shoots differentiate in quality. All the above inhibits the preserving.

### 8.1.4 Microorganism Invasion and Inflection

Apart from physiological activity, microorganism invasion and infection are main reason which leads to going bad and rotten as well. Different from fruit, which has controllable delicate harvesting, shoots face the second invasion and inflection from microorganism in the mud. Besides, harvesting knives and other tools may cause extra inflection.

### 8.1.5 Cutting Features

In preserving, especially before entering supermarkets, shoots must be cut in dose.

Followings may influence the preserving. (1) Smooth cutting interface and less injured cells may deduce the wound respiration. (2) Different cutting interfaces may influence the respiration.

## 8.2 Key Techniques in Preserving

Preserving is systematic and requires effective harvesting technology. Two problems must be solved: How to prevent the rotting that comes from the bacteria microorganism invasion and inflection and how to degrade the physiological activity, delay the reparation climax and avoid the moisture diminishing and structure aging because of physiological activity.

### 8.2.1 Researches on Controllable Harvesting Techniques

Shoots are often inflected by microbes in harvesting. It is the main reason that causes rotting in preserving. Meanwhile, big wound area causes respiration climax in 5 minutes and degrade the quality. Followings should be researched on and carry out the technical standard.

**Fiberization degree.** Know about certain fiberization degree and guarantee the flavor and enhance the preserving.

**Cutting area control.** Reduce the cutting area which may cause wound respiration in harvesting.

**Harvesting approach.** Select edgy tools and reduce the shoot cell sprain.

**Moisture-molding technology.** Piling up after harvesting guarantees the least moisture-diminishing.

**Shoot-body grading.** Study different grading standards, purchase and preserve accordingly.

### 8.2.2 Bacteriostasis and Mold-proof Techniques

Main microbes that influence shoots preserving are from soil, diseases and insect pests in shoot body and the air. Wound area is the first target to be attacked. Therefore, main measures on bacteriostasis and mold-proof should be enacted according to the wound area. Meanwhile, it is very important to sterilize before preserve because shoots can be edible without cooking. It requires extreme caution when selecting secure and nontoxic agent.

#### 8.2.2.1 Filming technology

Filming technology is a high molecular and liquid covering of the wound area. A thin and even coat will form after dryness. The coat can reduce the wound respira-

---

tion, diminish the consumption of nutrients and extending the storage time. In addition, it can reduce the evaporation and maintain the fresh and fullness. It can also reduce the rotting caused by microbe.

Filming material varies. It mainly consists of hydrophobic materials, water, surface active substances and water soluble high molecular materials. It is made by emulsification, breaking up, heating and sterilizing. The ideal filming material should own following features: certain consistency and easy to form film; formed film must be even, consistent and functions well in preserving; nontoxic, edible and no rare delicacy. Semper filming preservative is an example that is composed of saccharose ester, sodium cellulose glycolate, fat acid and diglycerol. All of them are natural and nontoxic. In Japan, compost is made of starch, protein and macromolecular solution added with vegetable oil, the compost functions well in oranges and apples. Yuan Yihua and Fan Mingtao studied the film on tomatoes, pimientos and cucumbers by using chitosan. The results indicated good preserving. However, it will worsen the preserving if non-proper filming technology is applied, such as less sterilization or virus in shoot-body. Sucrose, chitosan and amyllum are microbe-favorable culture medium, so film materials are polluted first and then cause the shoot body rotten.

#### **8.2.2.2 Anti-bacterium preservatives**

In worldwide, bactericide is often used to inhibit the rotting after harvesting the fruit and vegetable. Since shoot harvesting is under poor management, microbe inflection will happen much more than in other fruits and vegetables. Therefore, bactericide is indispensable in shoot preserving, storing and transporting. The first principle of selecting antiseptics and mould-proof agent is to be focused on the certain disease after harvesting, so it is must-do work to make a separating and identifying on the main germ in the harvested rotten shoot. Second, the level of residue must conform to the health requirements. Besides, be aware of the drug-fast coming from the pathogenic bacteria. Several main antiseptics and mould-proof agent are introduced by the followings:

**Organic acid.** In solution with certain pH, sorbic acid, lactic acid and citric acid can well inhibit bacterial reproduction.

**Chlorine and hypochlorite.** It is mainly used to the water disinfection and decrease the bacteria microbe. In Japan, shoot enters directly the supermarket after being disinfected by 100 mg/kg hypochlorite and bulb up.

**Sulfur dioxide and sulfite.** It is mainly used to inhibit the rotting of the harvested crop using  $\text{SO}_2$ .

**Other bactericide germicide.** carbolic acid, sec-butylamine, probenazole, aliette and hydantoin are often seen in temporary commercial bactericide germicide.

The key point is to make selective use. One is to mainly target on the pathogenic bacteria that causes rotting. The other is to guarantee less residue and low-toxic.

### 8.2.2.3 Radiation sterilization approach

Isotope is often used in irradiating preserving. Emitter of  $^{60}\text{Co}$  and certain amount irradiation can sterilize the shoot body and retard the physiological activity to some extent. However, capital construction investment is excessive, so restricted parts can be used in preserving. There are other preserving approaches such as microwaving and ozone preserving.

## 8.2.3 Techniques of Retarding Physiological Activities

If physiological activities can be retarded in preserving fresh shoots, the respiration climax can be delayed as well and diminish the ethylene that can promote respiration. Shoot body-fiberization caused by over or severe wound can be avoided. The birth of microbe, caused by respiration heat in rising storage temperature, can be avoided as well. The main retarding approaches are chilling treatment, hormone treatment, air-component-adjusting treatment and thermal treatment.

### 8.2.3.1 Keeping low temperature

The temperature to sustain plants living usually ranges from 15-30°C. Respiration grows more impelling with the rising temperature and more active ferments. Respiration intensity grows by 100% - 150% with every rising 10°C, and can be degraded by lowering temperature. Respiration climax can also be retarded and so can be the birth of ethane of fruit and vegetable. In addition, the aging - promoting of ethane will be severely retarded in chilling surroundings. Therefore, each kind of fruit and vegetable has its respective storage temperature. As to shoot, storing temperature is the proper temperature in which the physiological activities diminishes to the lowest level without arousing any physiological maladjustment. Except for the studies on shoot, many others studies have been carried out. Su Yunzhong preserved shoot for 50 - 80 days in  $(1 \pm 0.5)^\circ\text{C}$  with other approaches applied. Liu Yaorong made the preservation last 3 months in  $1^\circ\text{C}$  with fast freezing ( $-18^\circ\text{C}$ ) applied.

### 8.2.3.2 Hormone treatment

Physiological activities are modulated by endogenesis hormone which is of low content in plants but of strong physiological activities. Some external-use hormone of proper concentration can retard the physiological activities.

Somatotropic hormone. if pineapple is steeped in 500 mg/kg NAA, the fruit ripening can be retarded and the sale time can be lengthened. Other somatotropic hormones are 2, 4D.

**Gibberellic.** Ripening of banana and mango can be considerably retarded if gibberellic (Products name is 920) is applied. The application is mainly to degrade the respiration intensity and delay the respiration climax.

**Cytokinin.** Some certain effect can be on longan and lychee. BA (benzyladenine) are often seen. Not popularized because of high price.

**Growth inhibitor.** Absciscic, salicylic acid and other natural inhibiting agent are included. Some synthesis inhibitors are Regim 8, molding element, ccc, and maleic hydrazide. Treating mango with maleic hydrazide can delay the ripening.

No extra reports have been found for the external-use hormone on shoots. In the light of the less consumption and good security performance, tests can be carried out with other approaches applied to preserve.

### 8.2.3.3 Air-component-adjusting treatment

Air-component-adjusting treatment, applied after harvesting, is to diminish the ethane that promote aging by adjusting the proportion of O<sub>2</sub> and CO<sub>2</sub> in the storing environment, aerobic respiration intensity can be degraded and anaerobic respiration can be avoided. This treatment is widely used temporarily in commercial preserving.

**Environmental adjusting.** Rise the CO<sub>2</sub> concentration and reduce the O<sub>2</sub> concentration in sealed storage space (such as cold storage house or plio-film of high density and airtight performance). Input CO<sub>2</sub> and O<sub>2</sub> through two air pumps. In Japan, bulb lettuce is stored in 0 – 5°C cold house, with the O<sub>2</sub> concentration 5 – 30 mL/L and CO<sub>2</sub> 60 – 100 mL/L. In addition, N<sub>2</sub> storing environment has been widely used in commercials.

In air-component-adjusting treatment, some other treatments can also have good preserving performance: (a) High-concentration-CO<sub>2</sub> processing in short time. In Japan, bulb lettuce is stored in 20% – 60% CO<sub>2</sub> for 12 – 18 hours and in cold house then; (b) Decompression storing: Decompress the air pressure in the cold house (bag) to 1/5 – 1/10 atm. (1 atm = 101,325 Pa); (c) Vacuum Packaging; (d) Gas replacement (pump out the input CO<sub>2</sub>).

Air-component-adjusting treatment is in its beginning in China because of poor equipment. It is widely used in Japan. Good perspective should be proved.

**Air-adjusting agent.** It refers to materials that can absorb O<sub>2</sub>, C<sub>2</sub>H<sub>4</sub>, CO<sub>2</sub> and substances that can produce CO<sub>2</sub>. Put the agent into the shoots piles and create a microenvironment of low O<sub>2</sub>, high CO<sub>2</sub> and low C<sub>2</sub>H<sub>4</sub> to retard the respiration. Some are as followings:

a) Ethane sorbent: Including physical adsorption sorbent and oxidizing adsorption sorbent. Physical adsorption sorbent are zeolite, calcium silicate and activated charcoal. It utilizes features that ethane can be easily oxidized. Oxidants are often

applied such as  $\text{KMnO}_4$ , hyper oxide such as calcium peroxide and sodium peroxide. Two kind of the mixture of sorbent are applied such as calcium silicate (20%) +  $\text{KMnO}_4$  (80%). The mixture can absorb and decompose millionth of ethane of low concentration in storing condition.

b) Deoxidation: It mainly utilizes the reducible materials such as Fe powder, Zn powder, dithionite and sulphite as dominant agent arranged with synergist. It is used to reduce the  $\text{O}_2$  in storing condition and retard the shoot respiration, such as iron powder (78 g) + NaCl 1g +  $\text{Ca}(\text{OH})_2$  6g + activated charcoal (15g). Then seal with fruit in a 1,000mL container.  $\text{O}_2$  will be completely removed after 4 days.

#### 8.2.3.4 Thermal treatment

In fruit and vegetable preserving, short-time heat treatment can kill or inactivate and injurious insects or pathogenic bacteria to reduce the rotting and change some metabolic process. Thermal treatment was a quarantine inspection. It is applied in recent years in the light of bacteriostasis, mould-proof, activities-retarding and no-chemical-remains features. Thermal treatments classifies into hot-water-steeping, moist steam and hot air treatment. Infrared or microwave also can be tested.

Shoot preserving technology should break the single-mould limit. Studies should start from effective harvesting measures, comprehensive bacteriostasis, mould-proof and activities-retarding features to more other studies.

Shoot growing sites scatter, especially in some remote hilly region. Integrated purchase is hard operational. Accordingly, some important details and need-to-study topics in preserving are listed:

Harvesting time. Focuses should be on the antiseptis, moisture-molding and short-term storage technology after harvesting and before for sale.

Purchase time. Processing technology in integrated purchase.

Transportation time. Proper transportation condition.

Factory storing. Storing capability for large amount.

Supermarket processing. Treatment and storing condition before entering supermarket as vegetables.

### 8.3 Bamboo Shoots Preserving Approaches

#### 8.3.1 Winter Shoots Preserving

Moso bamboo shoot is harvested in winter. It can be preserved by in-sand, sealing and refrigerating.

##### 8.3.1.1 In-sand

Lay 7 – 10cm thick moist sand (not sticky) in a wooden crate or fiberboard carton.



Select un-wounded winter shoot, lay upward, fill moist sand up in the air gap and beat to tight. Make 7 – 10cm sand above and stress to tight. Shoots can be arranged in multiple-level if the carton is capacious enough. Cartons must be placed in the dark and windless place. Shoots can be preserved from 30 – 50 days or even from 2 – 3 months.

#### **8.3.1.2 Sealing**

Place unwounded winter shoots in pottery jar or plastic film bag and seal tightly or seal by plastic films to reduce the moisture evaporation. Carbon dioxide released from shoot body can reduce the oxygen naturally and inhibit the respiration intensity. Shoots can be preserved from 30 – 50 days.

### **8.3.2 Preserving of Spring Bamboo Shoots**

Moso bamboo and others shoots in spring have poor preserving performance because shoot body contains more water. Freezing, sealing and salt water preserving are temporarily applied.

#### **8.3.2.1 Cold storage**

The freezing point of shoot fluid is  $-1.35^{\circ}\text{C}$ . Histolysis can be aroused in protein if the preserving temperature is too low. Before loading, cold house can be sterilized by 2.9% formalin. Air gaps must be remained among containers (baskets). Temperature and humidity must be maintained even. Transportation is avoided in refrigerating. Mixed-loading is prohibited. This method is classified to slow freezing and fast freezing. ① Slow refrigerating: Shoots are directly loaded in the cold house and the temperature is remained to  $-5^{\circ}\text{C}$  and comparative humidity is above 80%. Shoots can be preserved for at least 1 month if this method is applied. Shoot slices can be preserved for at least 1 year if preserved in  $-18^{\circ}\text{C}$ . ② Fast-freezing: Make the shoot body temperature drop to below  $-18^{\circ}\text{C}$  rapidly by using fast freezing mechanic devices. Then shoots are preserved under  $-10^{\circ}\text{C}$ . Steady freezing temperature must be maintained in preserving and shoots can be preserved for at least 1 year. Fast-freezing is proper for market.

#### **8.3.2.2 Sealing**

Select un-wounded shoots and sprinkle G81-1 preserving agent. Shoots are preserved in enclosed plastic film bags and can be preserved to 6 months in normal temperature.

#### **8.3.2.3 Salt water preserving**

Shoots is preserved in April and processed from June to July. Remove the wormed,

wounded and rotten shoots from the newly dug shoots. Cut off the non-edible bottom and pack according the size. Boil the shoots for 2 – 3 hours (Be aware of over-boiled). Refresh the water when each boiling is finished. Freeze the cooked shoots as soon as possible. Keep the shoot body temperature below  $-30^{\circ}\text{C}$ . Remove the shell and coat. Remove the downy wool between coat and bottom by using spring blow and keep the tip integrated. The remaining non-edible part must be cut off and keep the cutting smooth. Store the shoots in cement pool or big pottery jar after cleaning. Place the mixture of salt (5% – 8% weight of the cooked shoot) and citric acid. Seal with plastic film after filling and stress. Sprinkle bleach powder (0.2% – 0.3% ) on the surface. Shoots become edible 24 hours after cleaning in the water.

---

# CHAPTER 9

## Processing Technology of Bamboo Shoots

As natural and health food is becoming more popular with people, shoot, treasure of dishes and natural intestinal-cancer-proof food, wins much more attention. Shoot represents spring season and one of the major foods from forest. Apart from being edible freshly, shoots can be processed into packaged, dried, coating, sour and canned shoots. Production series have been gradually formed. Nutritive ingredients are bound to lose after shoots' being canned. According to estimate, protein, fat, soluble sugar and ash generally reduce by 9.5% - 15%, some even by 60%.

Processing series can be classified into traditional (roasting), canning (in salt water), confections and mixed-process (with meat). Processing can be classified into dried, canning, supplement, salt, dehydrated and frozen shoots.

### 9.1 Processing Equipment

The main equipment includes can sealing machine, stainless steel double layered pot, pressure sterilizing cooker, flexible package sealing machine and stainless steel operational table.

### 9.2 Methods of Processing Dried Bamboo Shoots

Dried shoot, delicious and handy, with long preservation, is easy to pack and transport. It is a kind of Chinese traditional food, and is classified into six standards: "phoenix tail", "sheep horn", short-tip, secondary-tip, yellow and supplementary tip. The processing is as following: grading of raw material—preliminary cooking—rinse—squeeze water—desiccate—dried shoots—grading—package—storage.

The principle and method of shoots processing:

Harvesting should be in season to keep soft texture and fresh character.

Digging before early April, at the initial growing stage of shoots. Generally shoots growing superficially away from the soil surface might grow up to low-quality culms. Therefore it should be harvested when its tips are still under the soil dehiscence, which is called "digging yellow mud". This kind of shoots, usually taken as the finest grade of canned material, is tender and delicious with the export price 2/3 higher compared with ordinary ones. Vigorous shoot with small fringing, black shell and dewdrop leaves should be left to grow up to culms to remain bamboo forest balance. Due to good illumination and loosen soil, shoots on forest border should remain growing to extend bamboo forest and increase the amount of harvest. Digging on-year shoots purposefully instead of off-year ones, which can transfer on- and off-year bamboo forest into balanced-year forest and increase production. Digging shoots after rain or in the morning is easy to identify its quality with the help of loosen soil and dewdrops on the leaves. Shoots should be dug towards the direction of its tips. The correct method is to cut off the shoot base at the joint of tip and rhizome rather than break the rhizome, otherwise it might affect the amount of harvest; or the broken length of shoot left in the soil might also influence the quantity of output. So dig against the direction of bamboo tips and take off mud, then cut off the tip (at the joint of rhizome and culm) with a hoe along the same direction of it. If tender shoot remains on the rhizome, its putrefaction might rot the rhizome as well.

Unearthed shoot is taken as good raw material for processing and is fresh in taste with higher nutrient content. After being heaved out of soil, shoot changes to be green or brown, staling and low quality. So covering up with fine soil before shoot is dug out of earth is an aid to prevent staling and increase quality.

In time processing: Raw material must be kept in a cool place, or else it will go taint, fiberizing because of basking in the sun and drench. Purchased shoot should be cooked in hot water as soon as possible. Unfinished raw material can be put into a water tank with primitive shell. To keep shoot fresh, the water immersion in the container should have 2-3cm depth of shoot left out of water.

The processing operation must be closely linked, in case shoot rot during the procedure.

Food sanitation should be guaranteed and safe against various pollutions.

Package and storage. Presently the bag of soft packed shoots is mainly made of nylon or the recombination of poly-acetum and polypropylene film. Suitable film thickness of nylon or poly-acetum should be 0.12mm, and 0.40 - 0.55mm for polypropylene film, with good mechanical features. After vacuum seal, there often appear some edge angles within the packaging bag, which might cause air leakage from pin hole. The height of edge hole is proportional to the vacuum degree, so keep an appropriate vacuum degree is necessary.

---

Softening treatment of dried shoot: keep shoot in the container for 60 minutes with the aqueous solution of 2% – 5% alcohol plus 10% – 20% salt and acidulous water.

The flow chart is as flows:

Shoot-shelling-preliminarycooking-rinse-dehydrate-ferment-sundry-driedshoot-shape shoot-package-storage

### 9.2.1 Water-soaked Shoot Slice

Wash tender shoots, clean and cut the base and staling section, then the shoots should be braised by steam for 3 hours in a wood retort. Afterwards the cooked shoots are shelled and cut up into two parts, which are baked to almost dry on hot floor and turn to appear yellow. In the end, shoots are baked optimum drying by warm fire. Besides, the tailpiece of shoot shell can be made into dried shoot coating.

#### 9.2.1.1 Raw material

Uncooked fresh spring/winter shoot.

#### 9.2.1.2 Cutting of shoot

Cut the tough base.

#### 9.2.1.3 Cooking

Put water into the pot; after the water boils, put the container of shoot into the pot and cover the pot with iron cap; continue to cook for about 2 hours by strong and homogeneous fire; when the fragrance is smelled, move the cooked shoot out.

#### 9.2.1.4 Shelling

Peel bold shells off the cooked shoot and cut the tough base; the surface should be smooth. Use spring bow to cut off the tender sheaths completely and scalp the shoot clean. At last cleave the shoot into two.

#### 9.2.1.5 Baking

Dispose the shaped shoot into baking bolter; during the first 10 – 12 hours the fire power must be strong, and the shoot should be flipped every one hour; lower the fire after 12 hours and flip shoot every 2 or 3 hours. Usually shoot should be baked for 48 hours, and the baked shoot appears golden yellow.

#### 9.2.1.6 Sulfuring

When shoot is almost dried up, sprinkle some water on it; then put the shoot into an

airtight sulphur box; shoot is fumigated by a vessel of burnt sulphur put under the box; 18 hours later, put out the burnt sulphur and leave the shoot in box for another 12 hours to absorb enough sulphur dioxide; afterwards open the box and take shoot out.

### 9.2.2 Smoking Dried Bamboo Shoot

Wash shoot off and shell it, cut into semi-finished shoot of 12 – 16cm long and 6 – 8 cm wide; put it into water (about 80 – 100°C) and precook for 15 – 20 minutes; fish the shoot out and dip it in clean water for half an hour; then leave it basked in the sun till it is close to full dryness; at last put it on firewood to be smoke dry.

### 9.2.3 Yellow Dried Bamboo Shoot

Choose big fresh shoot, cut off the tough base, shell and cut it into equal two parts; cooked by boiling water, leave it under the sunlight till dry. Such thin pieces of shoot are tender, dry, and clean with no bitter taste or mildew. Yellow dried shoot should be sealed within non-poisonous plastic bags for storage.

### 9.2.4 Dried Bamboo Shoot in Salt

Wash fresh shoot off and shell sheaths, cook it in pot; cut big shoot into four parts and small one into two, then wipe it with salt outside and inside; pile it up for 3 – 5 days with salty water poured over, then have it dried in sunlight or by baking. Dried shoot in salt must be sealed in jar for storage.

### 9.2.5 Sheep-tail Bamboo Shoot

Sheep-tail shoot is named according to its shape. The length of earthed shoot is 25cm. First the shoot is shelled and the tough base is cut off; then cooked in boiling water till it is done to a turn; add some salt in it (the proportion of fresh shoot and salt in cooking pot is 25:4), then continue to be boiled in mid-fire for 4 hours. When there is little boiling water in the pot, move the shoot out to cool down to the room temperature. Sheep-tail shoot is bottled or stored in jar for storage after grading. The shoot in container is sprinkled with white wine and put in a cool place. Due to its tender taste and fragrant smell, sheep-tail shoot keeps not only its original flavor but also reliable quality, which is considered as the vegetable food of high grade.



### 9.2.6 Filling Dried Bamboo Shoot

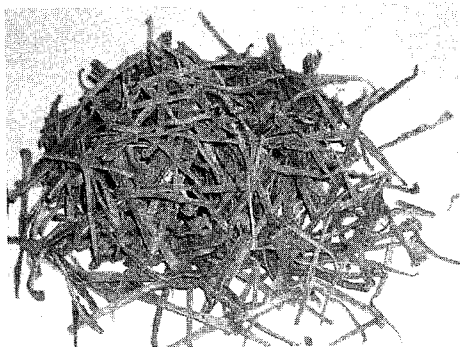

Cut the tough base off shelled shoot, and basked in the sun under sunlight till almost half dry. Fill some ingredients (a mixture of shallot, bean curd, sticky rice, red pepper, sodium glutamate and salt, etc.) throughout the shoot, then sew up the opening of the shoot with thread. After baking or sundry, the filling dried shoot is stored and turn to be edible

### 9.2.7 Dried Bamboo Shoot Slice

Wash fresh shoot off and shell sheaths, cut it into pieces and cook with boiling water. After cooking, put it in to clean water and cool down for 2 - 3 hours. Afterwards the shoot are baked dry, it is sealed within non-poisonous plastic bags and kept airtight in jar for storage.

### 9.2.8 Tianmu Dried Bamboo Shoot



Tianmu dried bamboo shoot is the famous brand traditional product of Zhejiang province, with a processing history of more than 400 years. The raw material includes *Phyllostachys nuda* McClure shoot 85% , *Phyllostachys praecox* Chu et Chao shoot, *Bambusa albo-lineava* Chia shoot etc.

The processing technique: cut off the tough base and shell-preliminary cooking (salt dosage: 30%) -flip the pot—recooking—burning (40 - 60°C)—pile up—macerate (salt dosage 6kg; shoot 50kg; water 30kg)—spread and press(4 - 5 days)—cut off the top point—twist—knead—baking—smash flat—shape—grading (Grade A, B, C, Damage grade and Broken grade)—dried—package (bamboo basket or plastic bag)—storage.

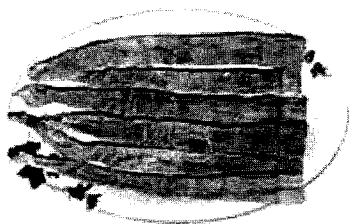

### 9.2.9 Ningguo Dried Bamboo Shoot

Ningguo dried bamboo shoot, famous for tender taste and pure flavor, is one kind of brining shoots which takes *Phyllostachys nuda* McClure shoot as major raw material. Its length should be 20 - 30cm when harvested. Traditional prod-

ucts include slices, baking shoot, large shoot, slim shoot, water shoot etc. New products such as water-bathed shoots, brining shoots, shoot slices appear recent years.

The processing procedure:

shelling—cooking—shaping—baking—grading—package—storage.

### 9.2.10 Horse-hoof Dried Bamboo Shoot

Named by its shape, horse-hoof dried shoot is a breed of high grade, which grows up in no-pollution area. The shoot contains high fiber, low fat and is considered a health protection food. The shoot protein contains 17 kinds of amino acids, microelements which have anticancer and aging-resistant function. Edible method: dip the shoot in warm water for 10 – 15 minutes and drain off, then fry or stew with meat.

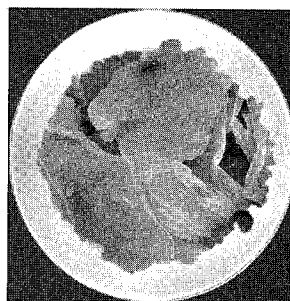

### 9.2.11 Soybean, Dried Bamboo Shoot in Brown Sugar

Boiling – cut into cubes—stew (bamboo shoot 50kg + soybean 10kg + brown sugar 1.5kg + salt 0.5kg)—baking—grading—package—storage.

The processing procedure: choose the bottom part of raw Spring shoot, and cook in boiling water for about 6 hours. When the shoot is fumed red, take it out and cut into cubes. Then put it into pot and stew with soybean, brown sugar and salt for 3 hours. After being baked, it turns to be edible.

### 9.2.12 Sour and Spicy Dried Bamboo Shoot

Bamboo shoot (50kg) + salt (0.7kg) + ingredients (red pepper, sauce and vinegar)

The processing procedure: cook the shoot with boiling water in the pot, then cut it into cubes and add some sugar. Put salt and other ingredients together into a hop-pocket and boiled with the shoot in the pot. When jam forms in the pot, take out the ingredient bag and add some vinegar to boil with bamboo jam for another 5 – 6 minutes. Afterwards the jam should be bottled for storage.

### 9.2.13 Spicy Bamboo Shoot

Bamboo shoot (50kg) + salt (1kg) + sodium glutamate (0.25kg) + right amount of spicy ingredients

All the above materials should be cooked in boiling water for about 4 hours, then dried up. Put the dried shoot in the pot to be braised for 1 hour, and packaged with plastic bags after oven drying or natural drying.



### 9.2.14 Sweet-and-sour Dried Bamboo Shoot

Damp dry Bamboo shoot(50kg) + sugar(1.5kg) + sour(0.5kg)

Cut the shoot into cubes or slices, boiled with water till the shoot turns to be soft. Wash the shoot with fresh water for 6 hours and stew it for 4 hours. When it is damp dry under the sunlight, press it into a jar with the mixture of ingredients mentioned above. After one day and night, take the shoot out and bask it in the sun till almost dry. At last, press the shoot mixed with sugar(1.5kg) into the jar another time and sealed for storage.

### 9.2.15 Sour Dried Bamboo Shoot

Shell the sheaths off the fresh shoot and cut it into slices; then cook it in boiling water ( the proportion of shoot and salt is 50:0.75). First boil the shoot up with roaring fire, then stew it with soft fire till the slice can be pierced through with a chopstick. Add appropriate amount of gradients ( red pepper, sauce, sour and sodium glutamate etc. ) into the pot, and continue cooking till the juice is almost drying up. After sun drying, the shoots can be packaged with plastic bags.

### 9.2.16 Dried Vegetable Bamboo Shoot

The proportion of potherb mustard and shoot is 4:1, plus appropriate amount of salt and red pepper.

### 9.2.17 Min Dried Shoot

Shell off sheaths—cut the tough base—wash—cooking—rinse—cooling—shelve—get sun-dried—flatten—package.

Yong'an dried shoot is also called "Min dried shoot", "tributary dried shoot" or "white dried shoot", which characterizes plum texture, golden luster, delicious and delicate taste as first-class product among all the dried shoots. The production of Yong'an white dried shoots is quite demanding. From being dug up to shaped up as finished product, it undergoes six procedures of digging up, shelling, cooking, soaking, squeezing and baking, which lasts nearly two months, with strict technical requirements at each stage. For instance, it demands good timing for digging up shoots as the saying goes "Tomb-sweeping Day in the second month, digging up the shoots five days later; Tomb-sweeping Day in the third month, digging up the shoots five days earlier"; "Three days earlier, digging up gold; three days later, digging up silver".

### 9.2.18 Dried Bamboo Shoot in Soybean Sauce

50kg bamboo shoot + 0.5kg salt + 1kg soybean sauce + a little monosodium glu-

tamate

### 9.2.19 Salty Dried Bamboo Shoot

50kg bamboo shoot + 1.5kg salt. When the *Phyllostachys praecox* shoot is processed into dried shoot, it is easier for storage and transportation, with increased economic value. It is also called Tea Shoot, which is edible at fresh, delicious for fried, stewed and braised dishes, with special flavor for soup. The Tea Shoot manufactured by Lingkou village of Shaolian in Xie County enjoys a high reputation for its being yellowish and tasty, not only selling well in Jiangsu, Zhejiang and Shanghai, but being sent to regions in South Asia like Hongkong and Macao as natural and nutritious delicacy.

Firstly, dig up shoots and shell off sheaths in time. Dig it up about Tomb-Sweeping Day when the shoots are just coming up out of soil. If it is too late, the shoots will not be edible any longer with stretching bamboo node and lignified fibre. Shell off all the dark brown sheaths while maintain the light yellow tender sheaths, cut off the tough base with roots, wash off soil and other spoils with fresh water, put them into the pot for cooking after being left trickling for a while.

Secondly, add an appropriate amount of salt and take control of the duration of cooking. Generally speaking, for 10 – 12 kg clean shoot, 1 kg salt is just right with certain amount of seasoning like fennel, Chinese cinnamon and Bunge prickly ash. Add a little salt at the bottom of the pot, put the shoot into the pot with tender tip pointing inward, heap them up as closely as possible, and add salt and seasonings for each layer without adding water. Start cooking with big fire for about one hour and roll the shoot ups and downs to prevent them from breaking off. About two and a half hours later, try to rip the shoot to see whether the color of inside pulp has turned from white or green into jade green. With a smooth and polish appearance, softened tender sheaths and no water left in the pot, we can put an end to cooking.

Thirdly, bake and turn it over frequently to ensure its color being light yellow. Bake the shoot upon getting out of the pot, air-drying and sun-drying are forbidden. Adopt bamboo sift instead of iron griddle. Guard off the smoke for charcoal fire, otherwise, the shoot will be tinged with smoky smell. The shoot is baked on the fire at the temperature of above 55°C, frequently turned it over to get vaporized rapidly and avoid getting burnt. While flipping the shoot, put them in order for packing. An hour later, use slow fire at 30 – 40°C to continue baking until it gets dry. With yellowish luster and feeling hard and not soapy, we can tell the baking is successfully done. Generally speaking, 50 kg clean shoots can yield 8 – 10 kg dried shoot after the baking.

Fourthly, grading and packing. Straighten the shoots after they are cooled down, then divide them into different grades according to a consistent standard of

size, color and texture. Pack them into specified plastic packages on the basis of different weight and size. Flatten the shoots, seal the package, and heap them up in dry places.

### 9.2.20 Dried Shoot Tips



Dried shoot tips can be made with various flavors.

### 9.2.21 Dried Shoot Clothing

Add salt, soybean sauce, monosodium glutamate, etc.

### 9.2.22 Dried Shoot Ear

Slice the bamboo shoot and add salt.

### 9.2.23 Mild Dried Shoot Ear

Slice the bamboo shoot and get it sun-dried.

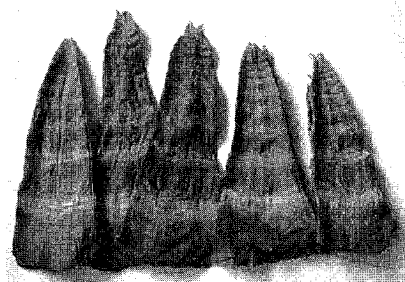

### 9.2.24 Dried Shoot Twig

Select shoot twigs and tails and add appropriate amount of salt and get the shoot sun-dried.

### 9.2.25 Crude Dried Shoot

Cut the shoot into slices or strips, add salt when it gets half dry, rub and press them tightly and get them sun-dried.

### 9.2.26 Crude Sour Bamboo Shoot

Submerge the shoot in a jug and add a small amount of salt. The processing method of sour shoot is as follows: cut the clean shoots into stripes, rinse them in fresh water, fill them into a jug tightly and seal the mouth of the jug. Place there for 10 – 15 days, and then the shoot will become sour and edible. During the whole process, oil is not allowed to get into the pot. Sour shoot with pepper and salt is edible at fresh, while the shoot without any flavorings is not edible unless it is cooked. Sour shoot is not only a seasoning, but also a dish with unique flavor, tastes delicious, sour, tender and crumbly. It changes any dish into a marvelous new taste. Sour shoot not only makes the pork not so greasy, but tastes good with fish, beef, chicken and vegetables. It caters to our appetite, at the same time, benefits our body. According to people of minority nationality of Tai, having sour shoot on daily basis

helps keep fit.

### 9.2.27 Processed Sour Bamboo Shoot

Slice the shoot into cubes, add 1.5 kg salt for every 50 kg bamboo shoot and add other seasonings and peppers.

## 9.3 The Salting Technique of Bamboo Shoot

### 9.3.1 Requirements for Main Raw Materials

Bamboo shoots, like *Phyllostachys pubescens*, *Ph. Edulis*, with tender texture and without bitterness or other odors, are ideal raw materials. As for the salt, it should meet the requirements of the first-class refined salt stated in GB5461 - 85 *Standard for Table Salt*. Similarly, the white liquor should be up to the demands stated in GB317 - 81 *Sanitary Standard for distilled and confected alcohol*. And the white granulated sugar should meet the requirement for the first-class sugar stated in GB317-84 *Standard for White Granulated Sugar*. As for seasonings like spice, fennel, Chinese cinnamon, Bunge prickly ash, aniseed, clove, dried ginger and liquorice, musty ones and impurities are not allowed to put into use.

### 9.3.2 The Technical Process

Raw material → cut off the tough base and shell off the sheaths → rinse → preliminary salting → put into jug and dip in the water → dress → pack → excavate air in the package and seal it → sterilize and cooling → heat preservation and inspection → pack them in cartons → store in warehouse → finished product

### 9.3.3 Requirements for Operation

#### 9.3.3.1 Cut off the tough base

Cut off the rough and tough base of the shoot, lacerate the sheaths lengthways with a knife, shell off the sheaths and wash off the shoot clothing.

#### 9.3.3.2 Rinse

Wash the shoot with fresh water, get them out of the water and trickle off the water on the surface.

#### 9.3.3.3 Preliminary salting

Add salt (6% - 8% of the raw material's weight), mix up, press tightly, preliminary salting for 24 - 48 hours when the bitter substances inside the shoot release together with the salty solution, alleviating the bitterness.

---

#### 9.3.3.4 Put into jug and dip in water

Choose container: Traditionally, choose pickled vegetable jug as container for ferment. Ideal pickled vegetable jug should have neither crack nor sand hole, with good glaze and outward shape.

The proportion of the pickled vegetable water between the pickled vegetable water and raw material is 1:1. Choose the water with rigidity above 6mg/L, such as deep ground water, spring water or tap water. Add 6% – 10% salt, get boiled, cooled down and filtrated. If the rigidity of the water is relatively low, it can be adjusted by adding proper amount of calcium chloride. Put the salty water into the pickled vegetable jug, inoculating by adding 15% – 20% first-class pickled vegetable water or pure lactobacillus culture medium, with composite bacterium at best. Add 0.5% white liquor, 2% – 3% white granulated sugar, 1% – 5% dried red pepper (depend on personal taste), 0.1% – 0.3% mixed flavors, which consists of 30% fennel, 20% Bunge prickly ash, 15% Chinese cinnamon, 15% aniseed, 5% clove, 5% dried ginger and 10% liquorice. These flavors are wrapped up with white gauze and put into the prickled vegetable water after they are mixed up and ground into powder.

Put into jug and dip in water: put the preliminarily salted raw material into the jug orderly, when they reach 6 – 10cm to the mouth of the jug, block it with a bamboo strip to prevent them from coming out of the water, place inside dish, cover the jug with the lid and pour water around the lid, allowing it get naturally fermented. The water around the lid can be made of about 10% salty water, which can prevent it from getting smelly. Grease is not allowed to get into the pickled vegetable water, otherwise, it will produce horrible smell as the impurity bacterium will propagate on its surface. If slight “powdery mildew” is discovered on the surface of pickled vegetable water, slowly pour in a little white liquor without stirring. Since the liquor is lighter than the pickled vegetable water, it can function as bactericide while floating on the surface. To prevent the “powdery mildew”, we can add supplementary materials containing vegetable antibiotics, such as garlic, balsam pear, perilla, red-skin radish, red-skin sugarcane etc. The water-soluble pigment within vegetable like red-skin radish can “color” the shoot, making it more attractive. When the acidity in prickled shoot reaches 0.4% – 0.8% after it gets fermented in the jug for certain period of time, get them out for packing.

#### 9.3.3.5 Dress

Cut the prickled shoot into proper size of stripes and slices with stainless-steel knife and pack them into bags in time, better within 2 hours from cutting to packing, because if the prickled shoot is exposed to the air for too long, it will induce more

bacteria, which will lead to difficulties in sterilization.

#### **9.3.3.6 Pack**

The ideal packing materials are airproof bags which is made of composite membrane and able to stand high temperature of 100°C without splitting up, like nylon or HDPE (high-density polyethylene) bag. After being weighed, the shoot are put into bags with a specially designed filter and pressed tightly. Scraps or juice should not be attached to the mouth of the bag, otherwise, it will affect the quality of sealing.

#### **9.3.3.7 Excavate air in the package and seal**

Excavate air in the package and seal it with vacuum packing machine, with vacuum degree 0.09-0.1MPa, heat synthesis width above 10mm, heat synthesis density adjusting to its temperature and duration.

#### **9.3.3.8 Sterilize and cool**

Since the prickled shoot is high acidic food with pH value about 3.5, Pasteurism can be adopted. Sterilization for 100g bags: 5 – 10 minutes below 10°C. After that, immediately put the bag in cooling water at the temperature of about 38°C.

#### **9.3.3.9 Temperature remain and inspection**

Leave the bags under the consistent temperature of 28°C + 2°C for 7days to check out non-vacuum or leaking bags. Sample the products to identify whether they reach the sensory, theoretical and microbial standards.

#### **9.3.3.10 Pack in cartons**

After the inspection, qualified products are packed in cartons, which are enlaced and stored in warehouse for sale.

### **9.3.4 Quality Standard**

Sensory standard involves color, scent, taste and texture. Color: yellow; Scent: special flavor of prickled shoot with certain ester savory; taste: mild sour and salty tinged with spice; texture: tender and crumbly. Theoretical standard: salt (NaCl, g/100g) 4 – 6; lactic acid (CHO, g/100g) 0.4 – 0.8; arsenic (As, mg/kg)  $\leq 0.5$ , plumbum (Pb, mg/kg)  $\leq 1.0$ . Food additives are up to the requirements stated in GB2760 Food Additive Standard. Microbial standards: Escherichia (per 100g)  $\leq 30$ , nosogenetic bacterium (intestinal nosogenetic bacterium and nosogenetic cocci) should not be found.

## 9.4 Water-boiled Bamboo Shoot

Water-boiled bamboo shoot refers to a series of canned products of water-boiled winter moso shoot, water-boiled spring moso shoot, water-boiled small bamboo shoot, which are made of natural, non-pest, non-polluted fresh shoot and pure groundwater. Its flawless white and good shape with shoot fragrance will stimulate the appetite. Besides, medically regarded as “king of health-keeping food” and “street cleaner” for intestine, it helps digest, clean intestine and stomach, reduce fat, guard against constipation, prevent and cure gall-stone, esophageal cancer and colonic cancer. Meanwhile, it has assistant curative effect for hemorrhoids and phlebitis.

Quadrangle canned fresh water shoot is an export canned food to Japan. In our country, this kind of product mainly adopts two types of large can, 18 liter and 9 liter, which cannot stand different strains and are prone to lose original shapes. So it is always sterilized at first and then sealed, which is the major technical difference between the quadrangle canned fresh water shoot and traditional canned products. In international trade, quadrangle can is generally put into category of vegetable rather than canned food.

### 9.4.1 Technical Process

Check up and accept raw material → boil → cut off the tough base and shell off the sheaths → flip off the shoot clothing → rinse → dress → shape classification → grade → weight → fill cans → sterilize under normal pressure → add water → adjust acidity → add solid citric acid

↓

Sterilize the can ← seal the can → natural cooling → store in warehouse → heat preservation → inspection and pack → finished product

### 9.4.2 Technical Key Points

#### 9.4.2.1 Sterilizing

for most processing of canned shoot, sterilizing treatment under high pressure is adopted, since canned shoot is a medium acidic food with pH value 4.5 -5.3. However, we tend to adopt the treatment for acidic canned food acidity refers to Japanese Agricultural Standards, that is, two hours' treatment under normal pressure, aiming at roughly killing microbe. But for spores bacilli and mildew spores, they can not be wiped out because they can stand heat, acid and dryness. However, since they are not easy to propagate in adverse environment, such as acid one, we can contain the increase of these heat-resistant bacteria when the acidity is adjusted to pH 4.2 -

4.5.

There are two ways to sterilize:

**Boiling below and steamer up.** Put two layers of shoot cans covered with “false lid” (with small holes in the lid) into the sterilizing pool. Half of the lower cans are immersed in the water while the upper ones are exposed to the air. Cover the pool. When the water in the pool gets boiling, sterilization is conducted by boiling water for lower cans and steamer for upper ones. The advantage rests with keeping the pool water out of the shoot can to keep it clean. While the disadvantages are: the sterilizing effect is relatively poor, it is hard to take control of and cans become easier to get bulged or burst.

**Water boiling.** Submerge all the cans in the pool and sterilize bacteria with boiling water. The advantage rest with satisfactory effect of sterilization since the temperature at the center of each can may reach 104 – 105°C when boiling and evaporating. The disadvantage rest with impurity’s easy access to the can as water in sterilizing pool and water in shoot can are mixed together. So we have to keep the pool and the water in it clean. Besides, it is comparatively energy consuming.

**9.4.2.2 Adding water**

After sterilization, the water in the can will remarkably decrease because of evaporation, large bamboo shoot’s absorbing water and the shaking of suspender. So we have to add a certain amount of water. Meanwhile, as there are quite a lot of bubbles at the centre of shoot, we have to slightly press the tip of the shoot to release the gas and add water again. Generally speaking, water is added twice or three times in case the can should get “falsely” bulged to affect the quality of the product.

**9.4.2.3 Adjusting acidity**

Adjusting acidity must be carried out after the water – adding because the freshness and production period of the raw material vary, so does the pH values before and after sterilization. The pH value of finished shoot can should be within 4.2 – 4.5. If it is below 4.2, the product is too sour to taste good and the tin pot will be severely eroded. Above 4.5, the bacteria in can are unable to be restrained so that the can will easily get bulged. The common parameters for adjusting acidity are as follows (18 liter quadrate can):

---



pH value for shoot	5.4	5.5	5.0	4.8	4.6
Citric acid to add (g)	25	15	10	6	6
pH value for finished product	4.2-4.4	4.2-4.4	4.2-4.4	4.2-4.4	4.2-4.4

After the adjusted acid dissolves, the ideal pH value for the juice in the can is 3.8 - 4.0 and the finished product 4.2 - 4.5.

#### 9.4.2.4 Sealing

for quadrate can, sealing up the lid with the can body directly by the capper, which is different from the sealing of the double yapped tin can. To make it sealed, the error for the capper should be within +0.1mm.

#### 9.4.2.5 Cooling

wash the sealed shoot can with fresh water and carry them to the warehouse for natural cooling, which can sterilize the possible bacteria induced in the process of sealing.

### 9.4.3 Introduction to Fresh Water Shoot

#### 9.4.3.1 Fresh water winter shoot

With 3,000 years' of shoot-eating history, China is one of the earliest countries where shoots are regarded as food. Fresh water shoot is also called boiled shoot or canned shoot. The shoot is mainly produced in the Yangtze River area and other places in South China. It boasts rich nutrition, coarse fibre, microelements, various vitamins and amino acid. With 4.1g protein, 0.1g fat, 40g calories per gram in 100 g shoot and its non-polluted growing environment, it is now regarded as the best natural food. Recently, many people in Japan, Canada and Korea hold that shoot is an indispensable food for each dinner every day.

With winter shoot and moso bamboo shoot as its raw material, undergoing unique technical treatment of boiled shoot and sterilization under high temperature without adding any additives, packed and sealed by iron can, fresh water winter

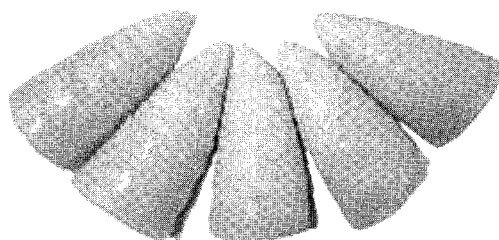

shoot is genuinely a pure natural food packed in health-friendly packages. Open the iron can, get the shoot out and wash it. Then it can either be used in dishes for stew or stew with wine and soybean sauce, or put into all kinds of dishes as supplementary material to enhance the flavor. The

shoot is rinsed and undergoes procedures, finally sterilized and packed into shoot product, such as water boiled pagoda shoot, oil stewed shoot, sour and spicy shoot slices, spicy shoot strips etc.

#### 9.4.3.2 Water-boiled shoot

Up to now, our country has three different production techniques for 18L water boiled shoot. Because of the different balanced pH values at stages of sealing, sterilizing and finished product, we try to discuss the security of products with different production techniques from the nosogenetic bacterium perspective, the acceptable standards and inspection methods that should be adopted by inspection and quarantine department for import and export.

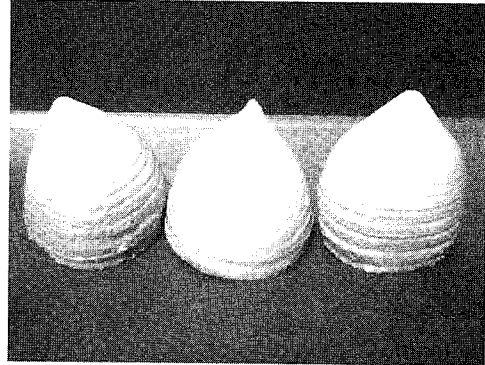

Processing techniques: ① Add water and leave it fermented naturally or adjust acidity, fill the can and seal it, sterilize by pasteurism, and the balanced pH value at shoot's center ends up with 4.2 – 4.60. ② Adjust acidity and sterilize by pasteurism (generally speaking, two hours below 100°C, and it is also used as air-releasing procedure), seal into finished product, with balanced pH value at shoot's center 4.6 – 5.0. ③ Adjust acidity and seal up, sterilize under high temperature and high pressure, with balanced pH value at shoot's center 4.6 – 5.20.

#### 9.4.3.3 Fresh water bamboo shoot

**Material and equipment.** ① Adopt fresh shoot as raw material, with good shape, tender texture, short section, high quality. Put it into production as soon as possible (should be within 24 hours), otherwise, it'll get coarse and rough, not only the quality will be affected but less part of the shoot can be used. ② Packing material: heat-resistant bags for boiling. ③ Main equipments: interbedded pot, cooling groove, vacuum packing machine and high-pressure sterilizing pot.

**Production techniques.** Fresh bamboo shoot → shell off the sheaths → preliminary cooking → cooling → cut into cubes →

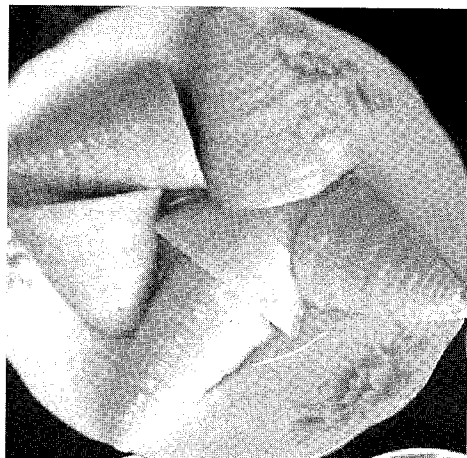

dip into the salty water→rinse→pack→excavate air in the package and seal it→sterilize→cooling→finished product.

**Key points for operation.**

a) Preliminary cooking and cooling: when the water in pot gets boiling, put the shoot in it and cook the shoot for 40 – 60 minutes. After that, immediately cool the shoot with cold water.

b) Dipping into the salty water: dip the shoot cubes into 0.3% salty water and flip them now and then.

c) Rinsing: remove dissoluble substances in shoot, especially some butyric or ammoniac acid by rinsing the shoot cubes in fluid water for 24 hours to reduce turbidity inside the bag after packing and the pH value by fermenting.

d) Packing, sealing and sterilizing: put the shoot cubes and slightly acid liquid (usually adopting citric acid to adjust acidity of the liquid with pH value about 4.8) into the bag, seal it with vacuum packing machine and sterilize for 60 minutes under high pressure and high temperature (113 – 115°C).

e) Cooling: put the finished product into cooling groove which is filled with fluid water.

## 9.5 Production Techniques of Flavoring Bamboo Shoot

### 9.5.1 Soft Packed Bamboo Shoot

The soft canned food was first studied by American army in 1946 for military usage and successfully provided "space food" for Apollo Lunar Landing plan. Some packages were approved to use in food production and sale by FDA of the nation (Food and Drug Administration) and USDA (United States Department of Agriculture) in 1975. Our country started to study this production technique since 1979 and put into market in 1981. Up to now, the production is carried out on a certain scale. On the current food market of the world, tin and glass cans are reducing gradually, being replaced by all kinds of soft packages.

**Technical Process:**

Raw material→preliminary cooking→cooling→preserve raw material→remove shoot clothing→rinse→dress and pack→add juice→seal up→sterilize under high temperature→check the finished product→store in warehouse

**Explanations for production techniques:**

**Raw material:** collect fresh shoot without insect and damages, with bone yellow or ivory white luster. The length of it should be 27 – 44cm. Cut off rough or lignified part and preserve the tip of the shoot.

**Preliminary cooking:** when the 0.2% citric acid water get boiling, put the shoot into the boiling water for cooking 4 – 6 minutes until it is cooked but not

mashed. The proportion of shoot and water in cooking pot is 1:5. When it is cooked, get it out of the pot at once.

Cooling: after preliminary cooking, put it into fluid water as quickly as possible. If it is not cooled down thoroughly, it will get too soft later.

Preserve raw material: fill barrel or pool with cooled raw material trimly and infuse 0.2% sodium metabisulfite, 0.3% citric acid, 2% salt solution to keep the submerged material fresh.

Remove shoot clothing: rub off the shoot clothing on the surface by hand or by machine, without damaging the shoot's tip.

Dress and pack: select shoots with similar size, color and quality, cut them into 15 – 17cm strips, put the raw material (90% of the net weight) into the package. While packing, try to make it look tidy and pretty. Besides, the inner package should not be polluted, which will affect the quality of sealing.

Add juice: after the water get boiling, add 0.2% citric acid, 0.1% benzyl formate, 10% salt orderly. Dissolved and filtered, it is put into the barrel with material in it. Pack the shoot into synthetic bag after it is cooled. While adding juice, use can packing machine to prevent the juice from attaching to the mouth of its inner side.

Seal up: seal it upon adding juice. Dry the mouth of inner side with clean cloth if a little vapor still left on it. Since the bag is filled with juice, the sealing machine should be adjusted, with gradient at least 75 degree, vacuum degree above 79.99kPa, sealing width above 0.6cm.

Sterilize: pressurized sterilization and pressurized cooling. Sterilizing formula: 5 – 25 – 5 min, pressurized cooling: below 100°C Pressure of sterilization: 49 – 98kPa, pressure of cooling: 78.4 – 117.6kPa.

Check the finished product: after sterilization under high temperature, check out impurities and inferior products. Examine the package to see whether it functions well. Qualified products are packed in cartons, which are enlaced and stored in warehouse.

#### Quality Standard

Color: the finished shoot should be bone yellow or ivory white, without green pieces. And the juice should be lucid instead of turbid.

Taste: with the unique flavor of shoot, without any uncomfortable odor.

Texture: tender and crumbly with no coarse fibred stuff involved. There are no marked differences in color or size of the shoot in their packages. Packing material can be synthetic pellicle bags with polyester outside and polyalkene inside or nylon outside and polyalkene inside. Specification: 16cm × 26cm. Net weight: 500g with solid matter 450g and juice 50g.

Sanitary standard: rot or mildew induced by nosogenetic bacterium or microbe

should not be found.

### 9.5.2 Oil Stewed Shoot



Cut the shoot into strips with 5 – 6cm in length, 1.2 – 1.5cm in width. Rinse in fluid water and wipe off the water. Put them into boiling water for 5 minutes to remove the bitterness. Put them in a pot with a panhandler, fry, boil and stew for 40 – 50 minutes. For 100kg shoot strips, add 2.5 – 3.8kg granulated sugar, 11.3kg soybean sauce, 0.4kg dark reddish brown liquid, 100kg fresh water. Add 9.3kg processed oil (refined for

10 minutes to remove the odor at the temperature of 180°C), cover the pot and stew for 10 minutes. Then get them out of the pot and add 50g monosodium glutamate after filtering out the juice.

### 9.5.3 Sweet and Sour Bamboo Shoot

Cut the shoot into slices or strips, put them into the pot for cooking until they get soft. Rinse with fresh water for 6 hours and stew on slow fire for 4 hours. Get them out and sun – baked to half dry. Mix them up with sugar (2 – 3kg sugar for every 100kg shoot, among which 1kg sugar is set aside for packing) and vinegar (account for about 1%), and press them tightly into the can. Get them out 32 hours later and get them sun – baked to nearly dry. Add the sugar and mix up for packing.

### 9.5.4 Sour and Spicy Shoot Slices

Cut the shoot into slices and boil them on big fire with 1.5kg refined salt for every 100kg shoot. Stew them on slow fire, add pepper, soybean sauce, monosodium glutamate and vinegar. Get them out of the pot when there is little juice left. Bake them dry for packing.

### 9.5.5 Sauce Bamboo Shoot

Cut the shoot into strips and cook until they get soft. Rinse in fresh water for 2 – 4 hours (change water once in the middle), put them into pot, add salt, soybean sauce and monosodium glutamate (1kg refined salt and 2kg soybean sauce for every 100kg shoot strips). Fry and stew for about half an hour, get them out of the pot and sun-baked. Get them braised for an hour and bake them thoroughly dry on the fire for packing.

### 9.5.6 Bamboo Shoot and Beans

Prepare 50kg spring shoot of moso bamboo, 10kg soybean, 15kg brown sugar, 0.5kg salt. Select the relatively tender and edible part of the shoot base, add water and cook for about 6 hours until the shoot pulp turn red. Get the shoot out and cut it into cubes, put them into the pot, add soybean, brown sugar and salt. Bake them dry after stew for 3 hours on slow fire.

### 9.5.7 Smoke Bamboo Shoot

Select shoot, shell of the sheaths, cut it into cubes with 14cm in length and 7cm in width. Cook and rinse in boiling water at the temperature of 100°C for 15 – 20 minutes and flip them ups and downs constantly. Get them out and dip them in fresh water for 30 – 60 minutes. Get them sun-baked and smoke-dried on the fire until they get thoroughly dry.

### 9.5.8 New Development of the Technology of Soft Package for Food

Recently, the food packing material is attracting attentions from various aspects, including functional packing material related to HACCP and packing methods closely related to circulating system, such as recycle after being used, waste treatment and integrated using; packing material for sterile package or half-sterile one; packing material for soft package of bactericidal food; packages which is light, user-friendly, visible through the package, easy to open and pour out with readable words; packing material without containing any substance to pollute the environment, etc.

### 9.5.9 New Tendency of Soft Package for Food

With the development of modern technology, the requirement of the market for food package is increasingly demanding. There're following various new tendencies for technical equipment of food soft package:

HACCP management technology, including preventing impurities from getting into measurement, convey belt which can be sterilized by heating, detectors of impurity or metal, index meter of environmental dust /floating bacteria, environmental sterilizing light and dust catcher on the surface of all kinds of packing material; filling system to shape containers under the sterile condition; automatic packing system of transparent soft membrane for vegetable and fruit to replace tray (package facilitation); import and export packages in different sizes and shapes, completed with facilities to fill in soft package or expel from it; high-speed shaping machine for PET bottles and its filling system; containers of 1 ton cubage; sterile system for rice packing; plastic containers of different shapes for milk, that is, the widely accepted durable 200 – 500 milliliter containers; the technology of preventing peeling off be-

---

tween the layers of multiplex packing material because of various food or flavoring ingredients involved; seeking low-cost packing equipment adapting to circulating conditions; on-line system of carrying out making bags and filling in at the same time; soft packing material which can let out the gas produced by food and other kinds of functional package; packages that attract attentions by proving that it is authentic product rather than counterfeit with holographic photos suited for all kinds of printings or tags.

#### 9.5.10 New Functions of Food Package Material

The primary function of package is to ensure the food quality. So it is very important to block steam and oxygen, without forming bubbles in winter or breaking off while falling on the floor, with strong resistance to heat for sterilization. At the same time, it can stand stirring and the heat for microwave, and it is economical and practical and in favor of sale. In overseas, they take holographic photos of all the paper boxes for wine on sale during the holiday to prevent counterfeit. Besides, water treatment is also deeply concerned, which further illustrates the increasing importance attached to waste treatment and integrated using.

#### 9.5.11 New-style Transparent PET Membrane of Plastic Membrane

Recent days witness a lot of news about dioxin. However, without fully understanding the practical situation, many reports regard PVC and PVDC as the cause of dioxin which leads some enterprises to plate silicon oxidize or AL<sub>2</sub>O<sub>3</sub> membrane on PET membrane, taking advantage of this transparent membrane, functioning as obstruct to replace previous products. Recently, the monthly turnout of this kind of product has exceeded 1.2 million pieces. The basic materials for plating are nylon membrane and OPP membrane. Although it is still at the stage of development, it is widely predicted that the output of this kind of transparent plating equipment has reached 60 million per month. Since the silicon oxidize plated PET membrane boasts completely obstructive nature, it is always adopted to replace aluminum foil multi-layer packing material. However, its shortcoming is that the obstructive nature will drastically affected if the plated layer is damaged under the outside force of strain, heat vibration and bend during the courses of integrated processing, using and circulation of the packing material. Under the microscope, the tiny fissure can be seen on the plated layer. So before adopting this kind of membrane as packing material, we should master the changes of the quality in practical situations in advance. If we use nylon and OPP as basic material, we should take it into consideration that these basic materials themselves are prone to produce stresses, which makes it hard to stand the heat and strain during the plating process. Recently, researchers commit themselves to develop plated membrane with stable performance to

change the current situation.

### 9.5.12 New-style Food Packing Paper

Through incessant research and development, a lot of high-tech food packing paper has come forth on the market. For instance, the heat-preserving paper developed in the U. S. can transform the solar energy into heat energy, functioning as solar heat collector. The food can be heated if you put the food packed with this kind of material under the sunlight. Only when the package is open will the heat disperse.

The antiseptic paper produced by Japanese company also can be used for food packing. The production method is as follows: firstly dip the base paper in ethanol solution with 20% succinic acid, 33% sodium succinate and 0.07% sorbic acid, followed by drying. Food with juice packed in this kind of paper can be kept for three weeks at the temperature of 38°C without going bad.

Bean curd residue paper is a water-soluble paper made from bean curd residue. It is widely used for instant noodle, flavoring, barbeque, cake and fruit. The production procedures are as follows: firstly put adipic acid and proteinic enzyme into the bean curd residue, leave it discomposed, wash it with warm water, dry it into food fibre, add emplastical like yam, taro, dextrin, low polysaccharide, polypropylene glycol, etc.

Fruit residue paper is made from apple residue discarded by food industry. The production procedures are as follows: remove seeds and grains from the fruit residue, pound it into paper pulp, add appropriate amount of wooden fibre. This kind of paper is easy to discompose after it is used, either used as compost or recycled to make paper with little pollution, applying to food packing.

## 9.6 GMP of Bamboo Shoot Processing

Good Management Procedure (GMP) is a management system originated from the U. S. to guarantee the product's quality and safety. Food GMP is a system to ensure food's safety and quality, with purpose of guarantee the food safety and quality stability by making sure that relevant personnel, architecture and equipment and facility are in line with good production condition, avoiding operating food under an unsanitary condition or in the environment that may induce pollution or affect the quality. The key points lie in: confirming the security of food production procedure; avoiding different or poisonous substances and harmful microbes from polluting the food; double inspection system to prevent man-made mistakes; labeling management system; establishing a complete management system of production record and report files.

The "bamboo shoot product GMP" based on *Sanitary Requirement for Facto-*

---



*ries and Warehouses of Export Food and Sanitary Regulations for Enterprises of Export Can Processing*, aiming at carrying out international standards and relevant rule of laws in our country, elaborating on sanitary and quality principle and system of the factories in form of general documents to make clear the basic law and regulation for sanitary and quality work in factories. It consists of the following parts:

- (1) Range
- (2) Quoted standard
- (3) Definition
- (4) Sanitary and quality principle and quality goal
- (5) Organizing institution and its function
- (6) Sanitary requirement for environment

Including sanitary requirements for roads in factory, pollution source and production section; waste and offal treatment; discharging of liquid waste and industrial scraps.

- (7) Sanitary requirement for workshop and facility

Including the layout of processing workshops and production procedures; identifiers of different operating workshops; requirement for floor in workshop, door and window, wall and ceiling; requirement for light, antiseptis and ventilation in the workshop; requirement for operating table, instrument and tool, and other accessorial facility

- (8) Sanitary requirement for raw and accessorial material and water for processing

Including requirement for raw and accessorial material and inspection procedures; requirement for empty can and its inspection procedure; water for processing and its inspection; mutual pollution; drinking water resource; design of the water pump and requirement for water faucet; requirement for washing/ rinsing groove; water quality inspection and record.

- (9) Personnel requirement

Requirement and training of management and technical personnel at different levels; healthy habit and behavior; medical check-ups; washing hands and antiseptis, management of individual belongs.

- (10) Sanitary quality control in process

Including sanitary control in the processing course; sanitary standard and operation procedures; production procedures and operation requirements and its management; surveillance and control record on the spot; cleaning and sterilizing control in the workshop; sanitary quality control of sealed product

- (11) Sterilizing quality control

Including stipulating for sterilizing procedures and putting for records, the purchase, install, usage and maintenance of the immobile high-pressure steam sterili-

zing equipment, cooling water treatment and its record, treatment of inferior product

(12) Inspection and experiment control

Including inspection of stock, inspection and surveillance of production procedures, final inspection of can product and inspection of the record requirement, instrument and equipment for inspection

(13) Sanitary control of package, storage and transportation

Including sanitary condition of the warehouse, requirement for can package, can transportation, etc.

(14) Management system

Including production management, quality management, files of sanitary management system, management system of finished product in and out the warehouse, measures of rectifying errors and various recording systems.

---

## ***REFERENCES***

- Chen Y. 1984. *Cultivation and Utilization of Bamboo Species*. Beijing: China Forestry Publishing House.
- Cho KT. 1998. High Pressure Sap Displacement (HPSD) Method and Bethell Process for Treatment of Round Bamboo. Malaysia.
- Elizabeth A. widjaja. 1991. The Peculiar Preparation of Bamboo Shoots for Culinary Purposes in Indonesia. *J. Amer. Bamboo Soc*, 1&2(8):146 - 150.
- He QJiang, Li Qin, Weng Pujin, Hua xiqi. 2000. Studies on Formula for Making Seasoned Bamboo Shoot and Its Processing Techniques. *Jour. of Zhejiang Forestry Science and Technology*, (6).
- Hu Chaozong. 1986. Change of the Nutrition of Moso Bamboo Shoots with ages. *Journal of Bamboo Research*, 5 (17): 89 - 95.
- Huang LX. 1996. *Wood Pyrolysis Technology*. Beijing: China Forestry Publishing House.
- Jayanetti DL. 1998. *Bamboo in Construction*. Published TRADA Technology Limited and INBAR for DFID.
- Jiang SH, Zhang QS, Jiang SX. 2002. Development of Effective Utilization Theory and Applying Research of Bamboo Charcoal. *Journal of Northeast Forestry University*, 30(4), 53 - 56.
- Lai Suiwen, Cao Chiping. 2003. Study on Processing Technology of Low Salt Bamboo Shoot. *Modern Food Science & Technology*, (2).
- Liese W. 1998. Preservation of Bamboo for the Construction of the Houses for Low Income People. *Bamboo Housing Technology Transfer Workshop*.
- Lu Jiagui, Liu Wanjun, Xuli. 2002. Study on Effects of Different Preservatives on Fibrosis and Fresh - keeping of Bamboo Shoot. *Food Science*, (10).
- Ou Yangxian, Liu Yenlin. 2003. A Experiment in the Technological Process of Eatingsweet Bamboo Shoot Silk, (3).
- Pravabati Devi and H. Tombi Singh. 1986. Studies on Chemical and Nutritional Changes of Bamboo Shoots During Fermentation. *Journal of Food Science and Technology*, (23):338 - 339.
- Shi QuanTai, Yang Xiaosheng. 1992. Moso Bamboo Shoots' Nutrition and Human Health. *Proceeding of International Workshop of Bamboo Industrial Utilization*. Beijing: Dec.

- Wang Hongfeng, Chen Hongguo. 1999. Preservation Technology of Bamboo Shoots. *Guangdong Forestry Science and Technology*, 15(4):48 – 538.
- Wang Wei, Xiaojun, He Lianyong. 2004. Processing Technique of Handy Vegetables with Field Bamboo Shoot. *Food Science and Technology*, (12).
- Wu FC, Tseng RL, Juang RS. 1999. Preparation of Activated Carbons from Bamboo and Their Adsorption Abilities for Dyes and Phenol. *Journal of Environment Science, Health*, A34 (9).
- Xiao Kaien, He Jinlei, Zhong Mei, Li Hanyuan. 2003. Preparation of Ready-to-eat Bamboo-shoot Can. *Food & Machinery*, (2).
- Xu Li, Liu Wanjun. The Effects of Different Preservatives on Bamboo Shoot Fibrosis and Fresh-keeping. 2002. *Journal of Mountain Agriculture and Biology*, (2).
- Yang Xiaosheng, Shi Quantai. 2005. Preliminary Report on Cultivation of Selenium and Germanium Containing Shoot. *Jour. of Zhejiang Forestry Science and Technology*, Vol. 25, No. 5: 24 – 26.
- Ye CY, *et al.* 1989. *Integration Utilization of Bamboo Resource*. Shanghai: Shanghai Science and Technology Press.
- Yu Xuejun, Chen Qinghu, Wu Jiaseng, Wu Yuefeng. 2004. The Effects of Different Fresh-keeping Treatments on Postharvest Physiology and Storage of Bamboo Shoots in *Phyllostachys Prominens*. *Journal of Bamboo Research*, (1).
- Zhang QS, Jiang SH, *et al.* 2001. Research on Adsorption Properties and Relative Factors of Bamboo Charcoal on 2,4 – di – chloro Hydroxybenzene. *Proceedings of International Academic Discussion on Bamboo Charcoal and Bamboo Vinegar*, Linan, Hangzhou, China. 10 – 15.
- Zhang Qisheng. *Bamboo Resources in China and Future View for Its Effective Utilization*. 2000 International Symposium Bamboo Charcoal and Vinegar. Japan Kyoto, 6 – 7.
- Zhang Qisheng, Cheng Weishan. 2003. *Beijing: China Bamboo Handicrafts*, Second Edition. Beijing: China Forestry Publishing House.
- Zhang Qisheng, Jiang Shenxue, Tang Yongyu. 2002. *Industrial Utilization on Bamboo*. INBAR technical Report No. 26, Colour Max Publishers Limited.



*Technical Manual on*  
*Utilization of Sympodial Bamboos*

ISBN 978-7-5038-4931-2

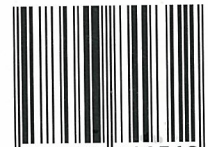

9 787503 849312 >

Price: RMB45.00